



FUEL INJECTION FUEL PUMP UNIT 12-932 REPLACEMENT INSTRUCTIONS

PRECAUTIONS FOR FUEL SYSTEM SERVICE:

To reduce the risk of fire and personal injury, it is necessary to observe the following precautions:

- Perform this repair **ONLY** in a properly equipped service facility
- Position the vehicle in a clear, level, well ventilated work area.
- Make sure there are no sources of spark or combustion near the work area.
- Perform work in a non-smoking area or post no-smoking signs in the area selected.
- Have a fully functional Class B fire extinguisher of adequate size (such as a 5 lb. CO-2 as a minimum) readily available.
- Disconnect the ground cable from the vehicle's battery before performing any operation involving gasoline, gasoline tanks, or gasoline lines.
- Allow the vehicle to cool before performing any operation which could possibly expose gasoline or gasoline vapors to hot parts, such as catalytic converters, hot light bulbs, or similar components.
- Avoid using extension cords or lights which might overheat or cause sparks.
- Avoid inhaling gasoline fumes and prolonged skin contact with gasoline. Promptly wash any skin/body areas that have been in contact with gasoline.
- Wear approved safety glasses while performing any repairs.
- When raising the vehicle to perform under-vehicle services, use proper hoisting or jacking equipment along with approved safety supports.
- When removing gasoline from a fuel tank, use an OSHA approved pump that is specifically designed for handling gasoline. **DO NOT USE** any other type of pump. Gasoline removed from a fuel tank must be stored in approved gasoline containers.

It is impossible to anticipate all possible risks and conditions under which repairs may be made to a fuel system. Therefore, in addition to the safety concerns listed, you are urged to carefully evaluate the hazards involved in such a service procedure and take whatever precautions that may be necessary.

PUMP INSTALLATION REQUIREMENTS

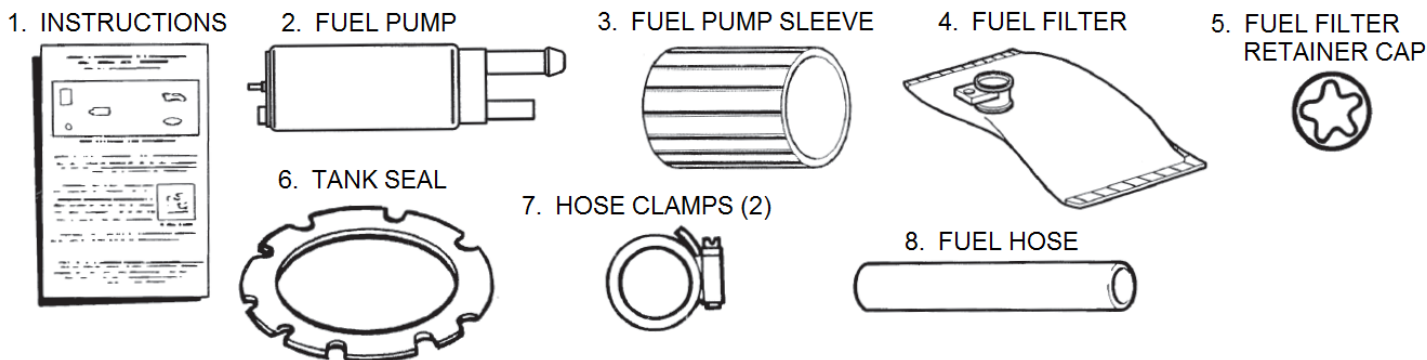

WARNING! This rotary fuel injection pump **WILL NOT** work on carbureted fuel systems. It is for electronic fuel injection only.

CAUTION: Read these instructions thoroughly from start to finish before attempting to replace the fuel pump.

MINIMUM TOOL REQUIREMENTS:

Hoist or end lift jack	OSHA approved safety stands	OSHA approved fuel transfer pump
OSHA approved fuel storage containers	Variety of mechanics hand tools	

FUEL PUMP REPLACEMENT INSTRUCTIONS:

NOTE: The words "PUMP BRACKET" used throughout these instructions means fuel pump, bracket, and fuel level sender (if so equipped).

1.0 PREPARATIONS

Relieve the fuel system pressure.

NOTE: The fuel system can retain gasoline under pressure for a considerable period of time. Opening a pressurized line could spray fuel, creating a risk of fire and/or personal injury.

1. Remove the fuel cap from the tank to relieve any tank pressure.
2. Locate the power distribution block and remove the fuel pump relay. Relay locations are described inside the cover of the power distribution block.
3. With the fuel pump relay removed, crank the engine to bleed down the fuel system pressure. The engine will start and stall several times. Continue to momentarily crank the engine several more times. Be sure to turn the ignition switch completely to the off position between cycles. Once the engine no longer tries to start, the fuel system pressure is relieved.
4. Disconnect the negative (-) cable from the battery and position it so it cannot accidentally make contact with the negative (-) battery post during the fuel pump replacement procedure.

NOTE: Be sure an appropriate fire extinguisher is readily accessible before continuing with the service procedure.

5. Drain the fuel tank with an OSHA approved gasoline transfer pump. Place the suction hose of the pump into the fuel tank through the filler neck. Be sure the hose is completely inserted into the tank. All of the fuel must be drained before trying to remove the fuel tank.

NOTE: Be sure the hose is completely inserted into the tank. All of the fuel must be drained before trying to remove the fuel tank.

2.0 FUEL TANK REMOVAL

1. Remove the fuel filler and vent hoses from the fuel tank.
2. Remove the skid plate and any shields that may interfere with removal of the fuel tank (if so equipped).
3. Support the fuel tank and remove the tank retaining straps.
4. Remove the fuel filler neck hose and tank vent hose.
5. Lower the fuel tank enough to access the top of the fuel tank.
6. Remove the fuel line connector safety retainers. Disconnect the 3/8" fuel line using the Ford special tool #T90T-9550-C (blue) or equivalent. Disconnect the 5/16" fuel line using the Ford special tool #T90T-9550-B (gray) or equivalent.
7. Remove any other lines and electrical connections from the tank.
8. Carefully lower the fuel tank out of the vehicle.

3.0 REMOVE THE PUMP BRACKET FROM THE FUEL TANK

1. Thoroughly clean the top of the fuel tank to prevent any dirt from getting into the fuel tank when the pump bracket is removed.
2. Remove the pump bracket attaching bolts from the tank.
3. Carefully remove the pump bracket from the fuel tank. Be careful not to bend the float arm or damage the float.

WARNING! HAVE ABSORBENT SHOP TOWELS READILY AVAILABLE WHEN REMOVING THE PUMP BRACKET. SOME FUEL WILL SPILL WHEN THE TANK UNIT IS REMOVED.

4. Check the inside of the fuel tank for foreign debris and clean out the tank if necessary.

4.0 REMOVE AND REPLACE THE FUEL PUMP

1. Remove the clamps from the rubber line that attaches the fuel pump to the pump bracket.
2. Remove the attaching strap bolt from the pump bracket and remove the strap.
3. Slip the pump, pump sleeve, and filter assembly out of the pump bracket.
4. Unplug the electrical connector from the pump by releasing the locking tab and gently pulling the plug out of the fuel pump. Discard the old pump, pump sleeve, and filter.
5. Install the new fuel pump into the pump sleeve.
6. Install the new inlet filter onto the fuel pump by firmly pushing it onto the pump inlet. Secure it with the filter retaining clip.
7. Slide the new hose onto the fuel pump outlet. Install and tighten the lower fuel line clamp.

NOTE: The hose must be cut to fit into the pump bracket.

8. Slide the upper clamp over the hose and slide it down out of the way. Determine the proper length for the hose and cut it to fit.
9. Reconnect the electrical plug to the pump. Be sure the locking tab snaps into place.
10. Slip the hose onto the bracket and push it far enough to allow the pump, pump sleeve, and filter assembly to slip into place on the pump bracket. Be sure the pump is oriented properly in the bracket.
11. Slide the upper hose clamp into its proper position and tighten it.
12. Reinstall the pump retaining strap and bolt. Tighten the bolt to the proper specification.
13. Remove the old tank seal from the pump bracket flange. Carefully slide the seal down over the pump and level sender assembly. Be sure to orient the seal properly before sticking it to the flange. Once proper orientation has been determined, it is best to make a locating mark on the flange and on the seal. Then, the protective paper can be removed from the adhesive side of the seal and be properly affixed to the pump bracket flange (Fig. 1).

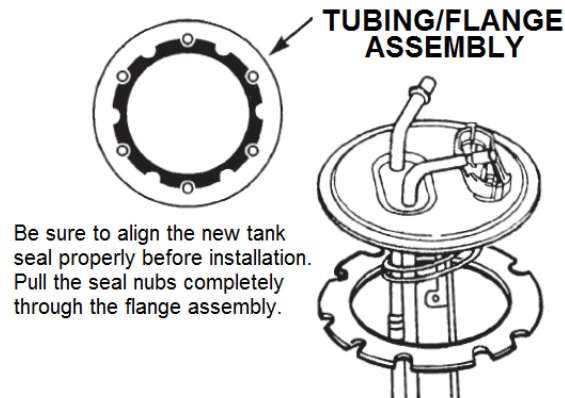

Figure 1

5.0 INSTALLATION OF THE PUMP BRACKET INTO THE FUEL TANK

1. Be sure the fuel tank is clean inside and carefully install the pump bracket assembly into the fuel tank. When the bracket is oriented properly, the fuel lines should be oriented toward the side of the tank that is next to the frame rail.
2. Install the pump bracket retaining bolts and tighten to manufacturer's recommended specification.

6.0 INSTALL THE FUEL TANK INTO THE VEHICLE

1. Lift the fuel tank into position in the vehicle leaving enough room to access the top of the tank. Re-install all fuel lines and electrical connections. Be sure all vent hoses, electrical connections, and fuel lines are properly installed before raising the fuel tank up into the vehicle all the way.
2. Install the fuel tank retaining straps and tighten the retaining bolts. Do not over-tighten the retaining strap bolts.
3. Re-install the filler neck and vent hoses.
4. Re-install any skid plates and shields that may have been removed.

7.0 WRAP UP

1. Using only equipment designed for use with gasoline, refuel the fuel tank with gasoline. **(NOTE: Be sure to clean up any fuel spills before proceeding.)**
2. Inspect the fuel system for leaks and correct them, as necessary.
3. With the ignition switch off, reconnect the negative (-) cable to the battery.
4. Re-install the fuel pump relay in the power distribution center.
5. Start the engine and inspect the fuel lines and connections for leaks. Correct any leaks, as necessary.
6. Clear any trouble codes in the electronic control system that may exist as a result of the fuel pump replacement procedure. If necessary, use the specific vehicle service manual for assistance.

TROUBLESHOOTING:

If the fuel pump fails to operate:

- Check the fuel pump fuse and fuel pump relay as outlined in the service manual.
- If the pump has power and proper polarity, check the remainder of the fuel system as outlined in the service manual.

NOTE: This fuel pump will not remedy malfunctions of the fuel pressure regulator, fuel injector(s), or other fuel system components.