



## FUEL INJECTION FUEL PUMP TANK UNIT 12-933 REPLACEMENT INSTRUCTIONS

### PRECAUTIONS FOR FUEL SYSTEM SERVICE:

To reduce the risk of fire and personal injury, it is necessary to observe the following precautions:

- Perform this repair **ONLY** in a properly equipped service facility
- Position the vehicle in a clear, level, well ventilated work area.
- Make sure there are no sources of spark or combustion near the work area.
- Perform work in a non-smoking area or post no-smoking signs in the area selected.
- Have a fully functional Class B fire extinguisher of adequate size (such as a 5 lb. CO-2 as a minimum) readily available.
- Disconnect the ground cable from the vehicle's battery before performing any operation involving gasoline, gasoline tanks, or gasoline lines.
- Allow the vehicle to cool before performing any operation which could possibly expose gasoline or gasoline vapors to hot parts, such as catalytic converters, hot light bulbs, or similar components.
- Avoid using extension cords or lights which might overheat or cause sparks.
- Avoid inhaling gasoline fumes and prolonged skin contact with gasoline. Promptly wash any skin/body areas that have been in contact with gasoline.
- Wear approved safety glasses while performing any repairs.
- When raising the vehicle to perform under-vehicle services, use proper hoisting or jacking equipment along with approved safety supports.
- When removing gasoline from a fuel tank, use an OSHA approved pump that is specifically designed for handling gasoline. **DO NOT USE** any other type of pump. Gasoline removed from a fuel tank must be stored in approved gasoline containers.

It is impossible to anticipate all possible risks and conditions under which repairs may be made to a fuel system. Therefore, in addition to the safety concerns listed, you are urged to carefully evaluate the hazards involved in such a service procedure and take whatever precautions that may be necessary.

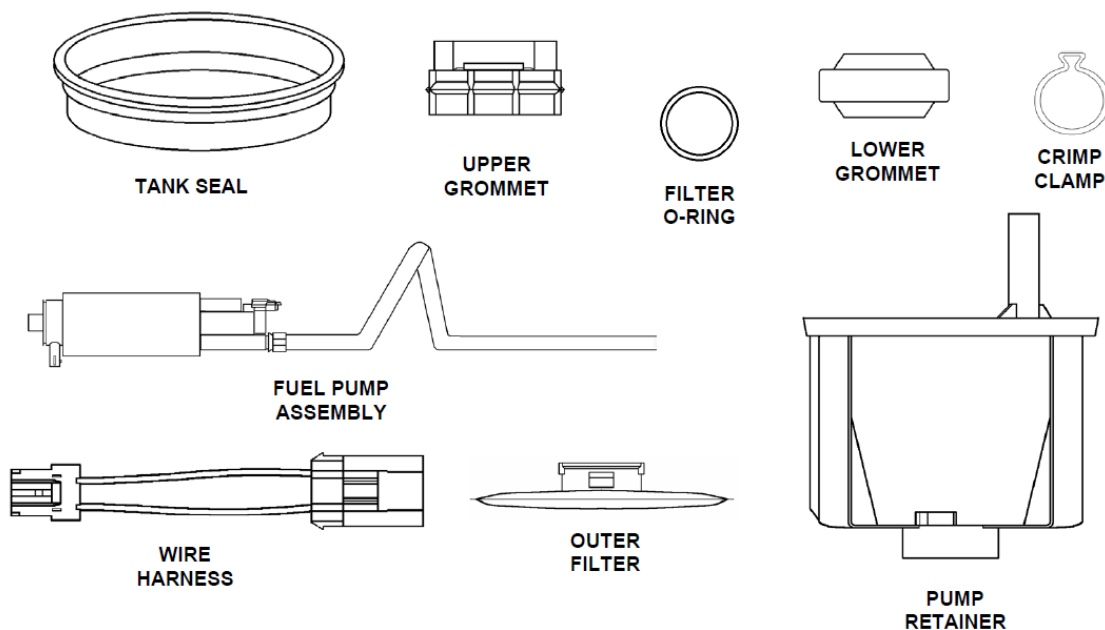

**WARNING!** This rotary fuel injection pump **WILL NOT** work on carbureted fuel systems. It is for electronic fuel injection only.

**CAUTION:** Read these instructions thoroughly from start to finish before attempting to replace the fuel pump.

**MINIMUM TOOL REQUIREMENTS:**

Hoist or end lift jack	OSHA approved safety stands	OSHA approved fuel transfer pump
OSHA approved fuel storage containers	Variety of mechanics hand tools	

**FUEL PUMP REPLACEMENT INSTRUCTIONS:**

**NOTE:** The words “tank unit” used throughout these instructions mean fuel pump module assembly, including the flange, bucket, hoses, and level sender

**1.0 PREPARATIONS**

Relieve the fuel system pressure. The fuel system can retain gasoline under pressure for a considerable period of time. Opening a pressurized line could spray fuel, creating a risk of fire and/or personal injury.

1. Remove the fuel cap from the tank to relieve any tank pressure.
2. Locate the power distribution block and remove the fuel pump relay. Relay locations are described inside the cover of the power distribution block.
3. With the fuel pump relay removed, crank the engine to bleed down the fuel system pressure. The engine will start and stall several times. Continue to momentarily crank the engine several more times. Be sure to turn the ignition switch completely to the off position between cycles. Once the engine no longer tries to start, the fuel system pressure is relieved.
4. Disconnect the negative (-) cable from the battery and position it so it cannot accidentally make contact with the negative (-) battery post during the fuel pump replacement procedure.

**NOTE:** Be sure an appropriate fire extinguisher is readily accessible before continuing with the service procedure.

5. Drain the fuel tank with an OSHA approved gasoline transfer pump. Place the suction hose of the pump into the fuel tank through the filler neck. Be sure the hose is completely inserted into the tank. All of the fuel must be drained before trying to remove the fuel tank.

**2.0 FUEL TANK REMOVAL**

1. Remove the fuel filler and vent hoses from the fuel tank.
2. Remove the skid plate and any shields that may interfere with removal of the fuel tank (if so equipped).
3. Support the fuel tank and remove the tank retaining straps.
4. Remove the fuel filler neck hose and tank vent hose.
5. Lower the fuel tank enough to access the top of the fuel tank.
6. Remove the fuel line connector safety retainers. Disconnect the fuel lines.
7. Remove any other lines and electrical connections from the tank.
8. Carefully lower the fuel tank out of the vehicle.

**3.0 REMOVE THE TANK UNIT FROM THE FUEL TANK**

1. Thoroughly clean the top of the fuel tank to prevent any dirt from getting into the fuel tank when the pump bracket is removed.

**WARNING!** HAVE ABSORBENT SHOP TOWELS READILY AVAILABLE WHEN REMOVING THE PUMP BRACKET. SOME FUEL WILL SPILL WHEN THE TANK UNIT IS REMOVED.

2. Remove the tank unit retainer ring from the tank.
3. Carefully remove the tank unit from the fuel tank. Be careful not to bend the float arm or damage the float.
4. Check the inside of the fuel tank for foreign debris and clean out the tank if necessary.

**4.0 REMOVE AND REPLACE THE FUEL PUMP**

1. Separate the top of the tank unit from the bottom by carefully inserting screwdrivers and expanding the top over its locking tabs.

2. Disconnect the electrical connector from the flange.
3. Carefully cut the clamp off of the hose on the regulator inlet and remove the hose.
4. Set the tank unit top aside.
5. Carefully remove the level sender from the electrical connector, note the level sender wire locations and release them from the connector.
6. Route the wires down through the pump retainer hole (Fig. 1).

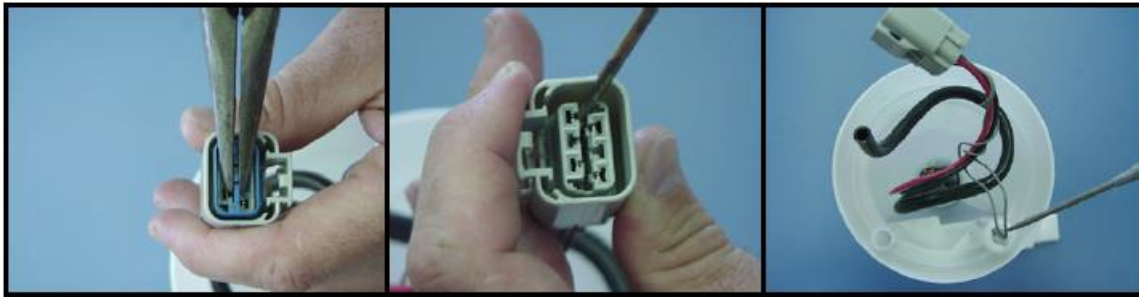

Figure 1

7. Carefully cut off the top of the pump retainer. Be sure not to damage the reservoir (See Fig. 2).
8. To remove the pump and retainer assembly, gently tap the reservoir assembly upside down on the bench, as shown in Fig. 3.



Figure 2



Figure 3

9. Remove the pump assembly.
10. Install the new upper pump grommet onto the fuel pump assembly.
11. Snap the supplied wire harness onto the pump assembly.
12. Slide the new pump lower grommet onto the pump.
13. Install the new pump and components into the tank unit reservoir.

**CAUTION: Be sure all the internal tank unit components are in place before continuing with this procedure.**

14. Place the new pump retainer into position and snap it into place.
15. Reroute the level sender wires up through the retainer.
16. Be sure the electrical connector on the supplied harness is correct. Some units have four inline terminal positions others have six positions (three over three). You may need to re-use your old plug housing by removing the terminals from one housing and installing them in the other. (See Figure 1.) **If this is necessary, be sure to note the positive and negative wire locations on the correct plug for your application before removing them from the old plug.** Install the wires into the correct locations in the plug.
17. Install the level sender wires into their appropriate location in the plug and snap the blue terminal retainer back into the plug.
18. Re-assemble the tank unit top onto the reservoir.
19. Plug the electrical plug into the bulkhead on the bottom side of the flange.
20. Slip the hose clamp onto the supply hose inside the module and connect the hose onto the regulator. Crimp the clamp using the appropriate tool.

## 5.0 INSTALLATION OF THE TANK UNIT INTO THE FUEL TANK

1. Install the new tank seal onto the fuel tank in its proper location.
2. Be sure the fuel tank is clean inside and carefully install the tank unit assembly into the fuel tank.
3. Re-install the retaining clamp and tighten to manufacturer's recommended specifications.

## 6.0 INSTALL THE FUEL TANK INTO THE VEHICLE

1. Lift the fuel tank into position in the vehicle leaving enough room to access the top of the tank. Re-install all fuel lines and electrical connections. Be sure all vent hoses, electrical connections and fuel lines are properly installed before raising the fuel tank up into the vehicle all the way.
2. Install the fuel tank retaining straps and tighten the retaining bolts. Do not over-tighten the retaining strap bolts.
3. Re-install the filler neck and vent hoses.
4. Re-install any skid plates and shields that may have been removed.

## 7.0 WRAP UP

1. Using only equipment designed for use with gasoline, refuel the fuel tank with gasoline. **(NOTE: Be sure to clean up any fuel spills before proceeding.)**
2. Inspect the fuel system for leaks and correct them, as necessary.
3. With the ignition switch off, reconnect the negative (-) cable to the battery.
4. Re-install the fuel pump relay in the power distribution center.
5. Start the engine and inspect the fuel lines and connections for leaks. Correct any leaks, as necessary.
6. Clear any trouble codes in the electronic control system that may exist as a result of the fuel pump replacement procedure. If necessary, use the specific vehicle service manual for assistance.

## TROUBLESHOOTING:

If the fuel pump fails to operate:

- Check the fuel pump fuse and fuel pump relay as outlined in the service manual.
- If the pump has power and proper polarity, check the remainder of the fuel system as outlined in the service manual.

**NOTE:** This fuel pump will not remedy malfunctions of the fuel pressure regulator, fuel injector(s), or other fuel system components.