



FUEL INJECTION IN-TANK FUEL MODULE 12-952, 12-953, & 12-984 REPLACEMENT INSTRUCTIONS

PRECAUTIONS FOR FUEL SYSTEM SERVICE:

To reduce the risk of fire and personal injury, it is necessary to observe the following precautions:

- Perform this repair **ONLY** in a properly equipped service facility
- Position the vehicle in a clear, level, well ventilated work area.
- Make sure there are no sources of spark or combustion near the work area.
- Perform work in a non-smoking area or post no-smoking signs in the area selected.
- Have a fully functional Class B fire extinguisher of adequate size (such as a 5 lb. CO-2 as a minimum) readily available.
- Disconnect the ground cable from the vehicle's battery before performing any operation involving gasoline, gasoline tanks, or gasoline lines.
- Allow the vehicle to cool before performing any operation which could possibly expose gasoline or gasoline vapors to hot parts, such as catalytic converters, hot light bulbs, or similar components.
- Avoid using extension cords or lights which might overheat or cause sparks.
- Avoid inhaling gasoline fumes and prolonged skin contact with gasoline. Promptly wash any skin/body areas that have been in contact with gasoline.
- Wear approved safety glasses while performing any repairs.
- When raising the vehicle to perform under-vehicle services, use proper hoisting or jacking equipment along with approved safety supports.

It is impossible to anticipate all possible risks and conditions under which repairs may be made to a fuel system. Therefore, in addition to the safety concerns listed, you are urged to carefully evaluate the hazards involved in such a service procedure and take whatever precautions that may be necessary.

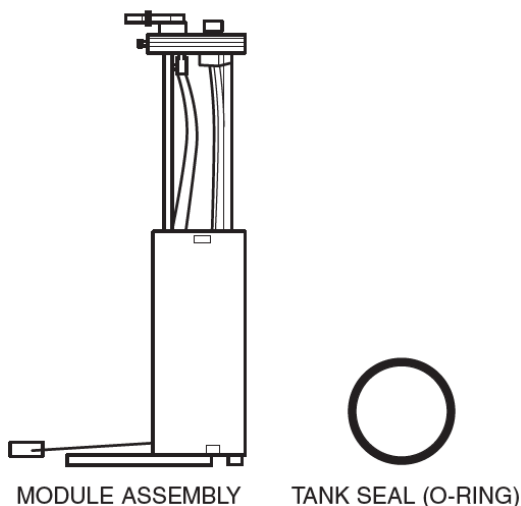

WARNING! This rotary fuel injection pump **WILL NOT** work on carbureted fuel systems. It is for electronic fuel injection only.

CAUTION: Read these instructions thoroughly from start to finish before attempting to replace the fuel pump.

MINIMUM TOOL REQUIREMENTS:

Hoist or end lift jack	OSHA approved safety stands	OSHA approved fuel transfer pump
OSHA approved fuel storage containers	Variety of mechanics hand tools	

MODULE REPLACEMENT INSTRUCTIONS:

NOTE: The words "MODULE" used throughout these instructions means the fuel pump, bracket, and fuel level sender assembly (if so equipped).

1.0 PREPARATIONS

1. Relieve the fuel system pressure.

NOTE: The fuel system can retain gasoline under pressure for a considerable period of time. Opening a pressurized line could spray fuel, creating a risk of fire and/or personal injury.

2. Locate the power distribution block and remove the fuel pump relay. Relay locations are described inside the cover of the power distribution block.
3. Remove the fuel cap from the tank to relieve any tank pressure.
4. With the fuel pump relay removed, crank the engine to bleed down the fuel system pressure. The engine will start and stall several times. Continue to momentarily crank the engine several more times. Be sure to turn the ignition switch completely to the off position between cycles. Once the engine no longer tries to start, the fuel system pressure is relieved.
5. Disconnect the negative (-) cable from the battery and position it so it cannot accidentally make contact with the negative (-) battery post during the fuel pump replacement procedure.

NOTE: Be sure an appropriate fire extinguisher is readily accessible before continuing with the service procedure.

6. Drain the fuel from the tank by using an appropriate siphon or approved fuel transfer pump. Gasoline must be stored in an OSHA approved safety container.

2.0 FUEL TANK REMOVAL

1. Raise the vehicle on a hoist or raise with a jack and secure it on jack stands.

WARNING! NEVER GET UNDER A VEHICLE THAT IS NOT SUPPORTED SAFELY ON JACK STANDS. IF USING A HOIST, BE SURE THE SAFETY LOCKING MECHANISM IS ENGAGED WHEN THE VEHICLE IS RAISED.

2. Remove the fuel filler and vent hoses from the fuel tank.
3. Remove the skid plate and any shields that may interfere with removal of the fuel tank (if so equipped).
4. Support the fuel tank and remove the tank retaining straps.
5. Remove the fuel filler neck hose and tank vent hose.
6. Lower the fuel tank enough to access the top of the fuel tank.

CAUTION: BE SURE THAT THE FUEL SYSTEM PRESSURE HAS BEEN RELIEVED BEFORE DISCONNECTING THE FUEL LINES. OPENING FUEL LINES UNDER PRESSURE MAY RESULT IN INJURY OR DEATH. SAFETY GLASSES MUST BE WORN WHEN USING COMPRESSED AIR, AS FLYING DIRT PARTICLES MAY CAUSE EYE INJURY.

(See section 1.0 PREPARATIONS of these instructions for the procedure to relieve fuel system pressure).

AFTER RELIEVING THE SYSTEM PRESSURE, A SMALL AMOUNT OF FUEL MAY BE RELEASED WHEN DISCONNECTING THE FUEL LINES. In order to reduce the chance of personal injury, cover the fuel line fittings with a shop towel before disconnecting, to catch any fuel that may leak out. Be sure to place the towel in an approved container when disconnect is completed.

7. Use compressed air to blow out dirt from the quick connect fittings. Disconnect the fuel lines.
8. Remove any other lines and electrical connections from the tank.
9. Carefully lower the fuel tank out of the vehicle.

3.0 REMOVE THE FUEL MODULE FROM THE FUEL TANK

1. Thoroughly clean the top of the fuel tank to prevent any dirt from getting into the fuel tank when the module is removed.
2. Remove the module snap-ring from the tank using the appropriate special tool, or other appropriate methods.
3. Carefully remove the module from the fuel tank. It may spring up from its position. The module may be full of fuel. Carefully discard the fuel in an approved container.

WARNING! HAVE ABSORBENT SHOP TOWELS READILY AVAILABLE WHEN REMOVING THE MODULE. SOME FUEL WILL SPILL WHEN THE MODULE IS REMOVED.

4. Check the inside of the fuel tank for foreign debris and clean out the tank, if necessary.

4.0 INSTALLATION OF MODULE INTO THE FUEL TANK

1. Be sure the fuel tank is clean inside and carefully install the module assembly into the fuel tank.
2. Align tab on front of sender with slot on the top of the fuel tank.
3. Be sure the new tank seal is installed before placing the unit into the tank.
4. Slowly apply pressure to top of spring loaded module until the module is flush with the tank.
5. Install the module retainer ring using the appropriate special tool or other appropriate methods. Tighten to the manufacturers recommended specification.

5.0 WRAP UP

1. Using only equipment designed for use with gasoline, refuel the fuel tank with gasoline. **(NOTE: Be sure to clean up any fuel spills before proceeding.)**
2. Inspect the fuel system for leaks and correct them, as necessary.
3. With the ignition switch off, reconnect the negative (-) cable to the battery.
4. Re-install the fuel pump relay in the power distribution center.
5. Start the engine and inspect the fuel lines and connections for leaks. Correct any leaks, as necessary.
6. Clear any trouble codes in the electronic control system that may exist as a result of the fuel pump replacement procedure. If necessary, use the specific vehicle service manual for assistance.

TROUBLESHOOTING:

If the fuel pump fails to operate:

- Check the fuel pump fuse and fuel pump relay as outlined in the service manual.
- If the pump has power and proper polarity, check the remainder of the fuel system as outlined in the service manual.

NOTE: This fuel pump will not remedy malfunctions of the fuel pressure regulator, fuel injector(s), or other fuel system components.

12-952, 12-953, 12-984
Revision Date: 2-15-17