

PART NO. 12630

CHEVY LUV V6/V8 TRANSMISSION MOUNT

- NOTE:** 1. TO BE USED TO INSTALL TURBO HYDROMATIC 350, ALUMINUM CASE POWER GLIDE, MUNCIE, B-W, SAGINAW 4 SP. TRANSMISSION INTO 1972-77 CHEVY LUV TRUCKS.
2. TO BE USED WITH HOOKER PART NO. 12606 WITH SMALL BLOCK CHEVY V8 CONVERSION KIT

INSTALLATION PROCEDURE - PLEASE READ CAREFULLY

1. REMOVE STOCK TRANSMISSION MOUNT.
2. USING STOCK BOLTS, BOLT BRACKET IN STOCK LOCATION AS SHOWN IN ILLUSTRATION.
3. PURCHASE A TRANSMISSION MOUNT FOR 1968-77 350 TURBO HYDROMATIC CAMARO. USING SUPPLIED BOLTS AND WASHERS ATTACH MOUNT TO BRACKET.
4. TIGHTEN ALL BOLTS.

ANY QUESTIONS? PLEASE CONTACT THE CUSTOMER SERVICE DEPARTMENT AT: HOOKER HEADERS, 1-866-464-6553.

DID YOU KNOW THERE IS MORE TO HOOKER THAN JUST HEADERS? OF COURSE, WE LOVE OUR HOOKER HEADERS. BUT HOOKER BUILDS MORE THAN THE ULTIMATE IN HIGH PERFORMANCE EXHAUST SYSTEMS. ASK YOUR DEALER

LIMITATION OF LIABILITY - DISCLAIMER: THE REGULATION OF EMISSIONS PRODUCTION, NOISE LEVELS AND SAFETY STANDARDS IS UNDERTAKEN BY THE FEDERAL GOVERNMENT, EACH OF THE FIFTY STATE LEGISLATURES AND BY MANY LOCAL MUNICIPALITIES, TOWNS AND COUNTIES.

HOOKER INDUSTRIES MAKES NO WARRANTIES OF MERCHANTABILITY, OF FITNESS FOR PARTICULAR PURPOSE, OR THAT ITS PRODUCTS ARE APPROVED FOR GENERAL USE, OR THAT ITS PRODUCTS COMPLY WITH LAWS, REGULATIONS OR ORDINANCES IN THE STATES WHERE THEY MAY BE SOLD TO THE ULTIMATE PURCHASER, THE CONSUMER.

UNLESS EXPRESSLY STATED TO THE CONTRARY IN THE CATALOG, INSTRUCTION SHEET OR PRICE LIST, THE ENTIRE RISK AS TO THE CONFORMITY OF ANY COMPANY PRODUCT IN ANY SUCH STATE AND AS TO REPAIR SHOULD THE PRODUCT PROVE TO BE DEFECTIVE OR NONCONFORMING, IS ON THE RETAIL PURCHASER, THE BUYER, THE ULTIMATE CONSUMER, OF SUCH PRODUCT AND IT IS NOT UPON THE SELLER, DISTRIBUTOR OR MANUFACTURER.

IN THIS CONNECTION, THE RETAIL PURCHASER, THE BUYER, THE ULTIMATE CONSUMER ASSUMES THE BURDEN OF THE ENTIRE COST OF ANY AND ALL NECESSARY SERVICE, ALTERATIONS OR REPAIR.

THE FOREGOING STATEMENT LIMITS THE LIABILITY OF THE MANUFACTURER.

CALIFORNIA VEHICLE CODE SECTIONS 27156 AND 38391 PROHIBIT THE ADVERTISING, OFFERING FOR SALE, OR INSTALLATION OF ANY DEVICE WHICH MODIFIES A VEHICLE'S EMISSION CONTROL SYSTEM UNLESS EXEMPTED. UNLESS OTHERWISE NOTED, HOOKER HEADERS HAVE NOT RECEIVED AN EXEMPTION FROM THESE CODE SECTIONS AND ARE NOT LEGAL FOR SALE OR USE IN CALIFORNIA ON VEHICLES ORIGINALLY EQUIPPED WITH CATALYTIC CONVERTERS. IT IS ILLEGAL, EXCEPT FOR RACING VEHICLES WHICH MAY NEVER BE DRIVEN UPON A HIGHWAY, TO REMOVE OR OTHERWISE RENDER INOPERATIVE ANY EMISSION CONTROL DEVICE ON REGULATED MOTOR VEHICLES-CHECK CATALOG LISTINGS TO INSURE PROPER APPLICATION. IN THE OTHER 49 STATES, UNLESS OTHERWISE NOTED, HOOKER HEADERS ARE NOT LEGAL FOR POLLUTION CONTROLLED MOTOR VEHICLES, EXCEPT FOR RACING VEHICLES WHICH MAY NEVER BE USED UPON A HIGHWAY AND ARE NOT INTENDED OR APPLICABLE FOR HIGHWAY USE.

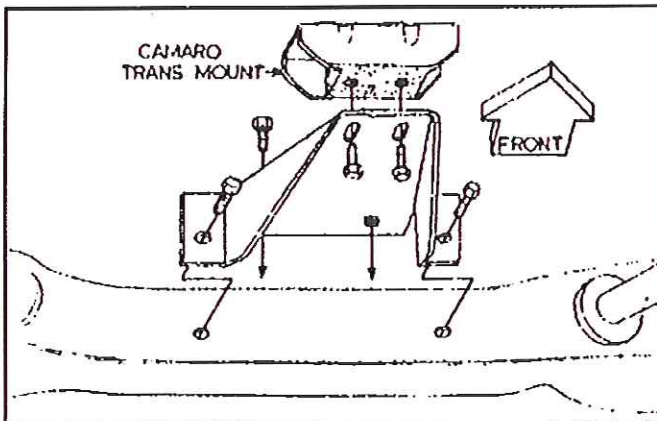

NOTE: DUE TO VARIATIONS IN MANUFACTURING, SOME HOLES IN TRANSMISSION MOUNT BRACKET MAY NEED TO BE ENLARGED TO PERMIT INSTALLATION OF BOLTS.

12630



Super Competition