



HOOKER COMPETITION EXHAUST SYSTEMS

P/N 16520HKR (header back) & 16619HKR (manifold back)
1968-79 Chevy II/Nova, 1970-81 Camaro, 1978-81 Firebird
265-400

WARNING! Breaking in an engine with ceramic-coated headers **WILL** result in damage to the coating and will **VOID** all warranties. Ceramic-coated headers require several heat cycles to fully cure before they will withstand extreme heat. **HOOKER** recommends using a cast-iron exhaust manifold or an old header to break in new engines to avoid coating damage.

NOTE: P/N 16520HKR dual exhaust system was designed to be used with Hooker Competition Headers - P/N 2451HKR. If the dual exhaust is being installed with headers other than P/N 2451HKR, modifications will be required. Hooker will not assume responsibility for fit or performance.

NOTE: P/N 16619HKR will not fit stock manifolds that exit straight down.

NOTE: Mufflers are not supplied with this exhaust system. Hooker Headers has designed this kit for use with Hooker Turbo muffler P/N 21005HKR, 21105HKR, or any equivalent 2 1/4" I.D. inlet by 2 1/4" I.D. outlet single offset OEM muffler. Glasspack mufflers may be used with slight modifications.

NOTE: If your wheelbase is greater than 132", tailpipe extensions are required to provide proper tailpipe exit. Order extensions from local muffler shop.

BEFORE STARTING:

Your vehicle must be raised a minimum of 36 inches. A floor hoist is ideal. If no hoist is available, we strongly urge the use of axle stands as a safety measure. **CAUTION! Your car should NOT be supported on a bumper jack!** We recommend welding all pipe slip joints (headpipe to muffler, etc.). If no welding equipment is available at the time of installation, use the furnished clamps to secure the pipes until they can be welded.

INSTALLATION PROCEDURE – PLEASE READ CAREFULLY:

1. Remove the existing headpipe, crossover, and the single exhaust. Save old gaskets and sleeves from the stock exhaust headpipes.
2. Install the new headpipe front sections, using the old gaskets and sleeves and headpipe extensions. Tighten only enough to hold in place. On header duals, install the front header extensions to the collectors, using the new gaskets provided. **DO NOT TIGHTEN.**
3. Install mufflers, tailpipes, and all hangers. **DO NOT TIGHTEN.** See **Figure A.**
4. Hangers are to be located as follows: The first to be installed in the first inside bolt hole of the OEM muffler bracket (both sides). The next is to be installed in the front bolt hole of the OEM tailpipe hanger on the outside of the frame behind the rear wheel. See **Figure B.**
5. Cut the end of the tailpipes to desired length.
6. Make sure that all parts of the system are clear of frame members, all hoses, suspension, and brake lines. Starting at the headers, tighten all connections, making sure all parts are clear and will not leak or rattle.
7. Start the engine and check for leaks. Be sure that all brake lines, fuel lines, and electrical wires have sufficient clearance. Reroute, as necessary.
8. When finished, give your car a test drive, checking carefully for any new noises. After several days of driving, retighten all the bolts.

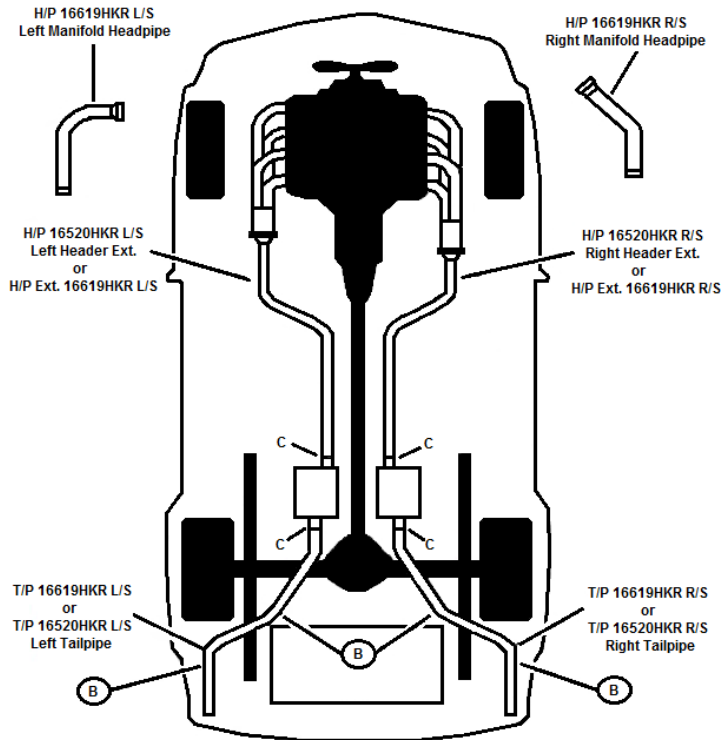

Figure A

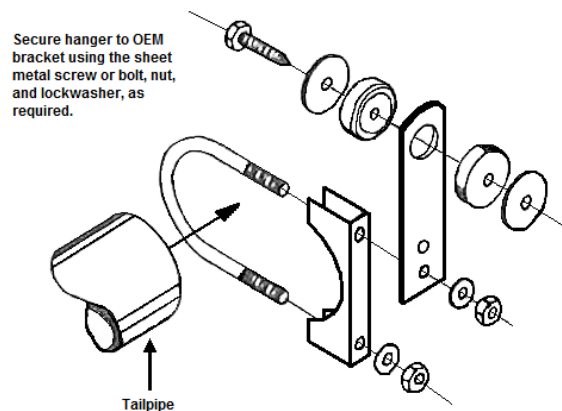

Figure B

LIMITATION OF LIABILITY – DISCLAIMER

The regulation of emissions production, noise levels, and safety standards is undertaken by the federal government, each of the fifty state legislatures, and by many local municipalities, towns, and counties. HOOKER Industries makes no warranties of merchantability, of fitness for particular purpose, or that its products are approved for general use, or that its products comply with laws, regulations, or ordinances in the states where they may be sold to the ultimate purchaser, the consumer. Unless expressly stated to the contrary in the catalog, instruction sheet, or price list, the entire risk as to the conformity of any company product in any such state and as to repair should the product prove to be defective or nonconforming, is on the retail purchaser, the buyer, the ultimate consumer, of such product and it is not upon the seller, distributor, or manufacturer. In this connection, the retail purchaser, the buyer, the ultimate consumer assumes the burden of the entire cost of any and all necessary service, alterations, or repair.

The foregoing statement limits the liability of the manufacturer.

California vehicle code sections 27156 and 38391 prohibit the advertising, offering for sale, or installation of any device, which modifies a vehicle's emission control system unless exempted. Unless otherwise noted, HOOKER HEADERS have not received an exemption from these code sections and are not legal for sale or use in California on vehicles originally equipped with catalytic converters. It is illegal, except for racing vehicles, which may never be driven upon a highway, to remove or otherwise render inoperative any emission control device on regulated motor vehicles. Check catalog listings to ensure proper application. In the other 49 states, unless otherwise noted, HOOKER HEADERS are not legal for pollution controlled motor vehicles, except for racing vehicles, which may never be used upon a highway and are not intended or applicable for highway use.

HOOKER TECHNICAL SUPPORT

Toll-Free Phone: 1-866-GOHOLLEY

Phone: 1-270-781-9741 Fax: 1-270-781-9772

For online help, please refer to the Tech Service section of our website: www.holley.com

www.ilovemyhookerheaders.com

**16520HKR
16619HKR
Date: 6-16-11**