



COMPETITION CARBURETORS MODEL 4150 ALUMINUM ULTRA XP SERIES

Installation and Adjustment Instructions 199R10565-1

CONGRATULATIONS on your purchase of the **HOLLEY ALUMINUM ULTRA XP Series** carburetor! We feel that you have purchased the finest performance carburetor manufactured today. Should you need information or parts assistance, please contact our Technical Service Department at 1-866-464-6553 or 1-270-781-9741, M-F, 8 a.m. to 6 p.m. & Sat 9 a.m. to 3 p.m. CST. Please have the part number of the product you purchased on hand when you call.

WARNING! These instructions must be read and fully understood before beginning installation. Failure to follow these instructions may result in poor performance, vehicle damage, personal injury, or death. If these instructions are not fully understood, installation should not be attempted.

APPLICATIONS:

P/N	USE	Calibration	CFM	SECONDARIES	BOOSTER TYPE
0-80801	Competition	Gasoline	600	Mechanical	Down Leg
0-80802	Competition	Gasoline	650	Mechanical	Down Leg
0-80803	Competition	Gasoline	750	Mechanical	Down Leg
0-80804	Competition	Gasoline	850	Mechanical	Double - step Down Leg
0-80805	Competition	Gasoline	950	Mechanical	Double - step Down Leg

NOTE: These carburetors are not designed to pass any emissions laws. They are to be used only for competition use/off-road vehicles or vehicles that are not required to comply with any exhaust emissions standards.

INTRODUCTION:

Holley Performance Products has written this instruction sheet for the installation of the **HOLLEY ALUMINUM ULTRA XP** carburetors. This instruction sheet contains all the information needed to install these carburetors. Please read all the **WARNINGS** and **NOTES**, as they contain valuable information that can save you time and money. Holley Performance Products cannot and will not be responsible for any alleged or actual engine or other damage, or other conditions resulting from misapplication of the carburetor described herein. However, it is our intent to provide the best possible products for our customer; products that perform properly and satisfy your expectations.

GENERAL INFORMATION:

- This instruction sheet cannot contain all of the information, which may be desired by some individuals. Further clarification is available in **HOLLEY CARBURETORS (P/N 36-73)**, published by H.P. books and available at your Holley distributor.
- An in-line fuel filter should be installed between the fuel pump and the carburetor.
- Recommended fuel pressure should be set at 7-1/2 psi maximum; 5 psi minimum. Fuel pressures above 7-1/2 psi can create severe fuel control problems and are not recommended.
- Fuel lines should be a minimum of 3/8".
- A non-restrictive open-element air cleaner kit is recommended.
- Jet extensions are supplied with these carburetors.
- The pump cam assortment kit is available under Holley P/N 20-12.
- Screwdriver is supplied for idle bypass adjustment.
- New or modified fuel lines are required (previously bowl machining was 7/8-20, **HOLLEY ALUMINUM ULTRA XP** carburetors come assembled with -6AN to SAE 8 port fittings).

List of Available Holley & Earl's Fuel Lines

Holley P/N	Earl's P/N	Description
34-42	AT104195ERL	-6 Single Inlet Ano-Tuff w/ Pro-Lite 350 Hose
*34-43	AT104295ERL	-8 Single Inlet Ano-Tuff w/ Pro-Lite 350 Hose
*34-44	AT104286ERL	-8 Dual Feed Ano-Tuff w/ Stainless Hose
34-45	104185ERL	-6 Single Inlet w/ Stainless Hose
*34-46	104285ERL	-8 Single Inlet w/ Stainless Hose
*34-47	104286ERL	-8 Dual Feed w/ Stainless Hose

*These hoses will require the purchase of 8AN fittings sold separately – 26-143-1 (black) or 26-143-2 (red).

REMOVAL OF OLD CARBURETOR:

WARNING! Prior to and after installing your new carburetor, manually operate the throttle lever, checking for any sticking or binding. Failure to do so may result in a runaway engine or a wide-open throttle condition, which could result in engine damage, personal injury, and/or death.

NOTE: Inspect the carburetor for any bent levers, or any possible shipping damage.

1. Disconnect the battery.
2. Remove the air cleaner.
3. Disconnect fuel line(s).
4. After removing the fuel line(s), slide a rubber cap plug over the end to prevent fuel from running out, which may create a fire hazard. Use a clean metal container to collect any spilled fuel.

DANGER! DO NOT SMOKE WHEN WORKING AROUND GASOLINE OR GASOLINE VAPORS. EXTINGUISH ALL OPEN FLAMES. AN OPEN FLAME, SPARK, AND/OR EXTREME HEAT COULD RESULT IN A FIRE AND/OR EXPLOSION CAUSING SERIOUS INJURY, DEATH, AND/OR PROPERTY DAMAGE.

5. Remove the throttle linkage and automatic transmission controls from the throttle lever. Disassemble and save the throttle return spring.
6. Remove the two front and two rear-attaching manifold flange nuts.
7. Remove the throttle cable bracket, if so equipped.
8. Remove the carburetor by lifting it straight upward. Sometimes, the carburetor can stick to the manifold gasket, requiring it to be pried loose. Before prying, double check to make sure all the carburetor attaching bolts and connections have been removed.
9. Place clean shop towels or rags into the manifold opening to prevent dirt or debris from entering the engine. Keep exposed ends of vacuum and fuel lines free from dirt.

WARNING! Failure to cover the intake opening with a clean towel could result in dirt or debris entering the engine. Dirt or debris in the induction system can cause engine damage, which may necessitate a complete engine overhaul.

10. Remove the gasket from the intake. Remove any gasket material that may have adhered to the manifold. **DO NOT** gouge the intake manifold sealing surface during removal of old gasket material.
11. Remove the shop towels from the intake and vacuum out the intake channel to ensure no dirt or debris is left in the intake system. Place a clean shop towel over the entire intake opening until you are ready to install the new carburetor.

FLUSHING THE FUEL LINES:

During fuel line installation, be careful to avoid introducing any dirt particles that could enter the fuel inlet and prevent the needle and seat from seating resulting in carburetor flooding, malfunctioning, and/or possible engine fire. In all cases where the fuel line has been cut, it is essential that it be cleaned to prevent contamination from entering your new carburetor. The fuel line must be flushed of rust, dirt, and other debris.

WARNING! Flush fuel lines only in a well-ventilated area and away from all sources of heat or flame. Failure to follow these instructions may cause gasoline vapors to ignite resulting in a fire or explosion, which may result in serious injury or death.

WARNING! Wear eye protection when performing this step. Failure to wear eye protection can result in gasoline or other contaminants entering the eye, which could result in permanent eye damage or blindness.

1. Disconnect the fuel line at the fuel pump.
2. Using a compressed air source, blow the fuel line clean.

INSTALLATION OF NEW CARBURETOR:

NOTE: This carburetor was designed with a dual mounting pattern, so that it can be installed on a manifold machined for a 4150 or 4500 series carburetor.

WARNING! Holley Performance Products highly recommends that a quality fuel filter be installed with any replacement carburetor to catch any debris that may still remain in the system. Any debris that may enter the carburetor can cause the carburetor to flood or malfunction. A carburetor that has a malfunction caused by debris in the system due to negligence of the owner will void the warranty.

1. Install a flange gasket on the manifold. If a spacer is being used, the installation order will be: flange gasket, spacer, and another flange gasket over the manifold stud.

WARNING! The carburetor should be installed directly onto the manifold without an adapter whenever possible. Sometimes an adapter can create problems with hood clearance, airflow, throttle linkage, fuel line attachment, and/or fuel mixture distribution. Operate the linkage to ensure correct travel by fully opening and closing the throttle by hand, as well as with the accelerator pedal (with engine off).

2. Place the carburetor in position over the four studs. Then, install supplied flat washers, tightening each nut gradually. Tighten in a criss-cross pattern to 60 in./lbs. Be careful not to over-tighten the nuts.

WARNING! Over-tightening the carburetor flange hold-down nuts may result in a warped or cracked carburetor throttle body. The carburetor hold-down nuts should be tightened down progressively in a criss-cross pattern to 60 in./lbs., to prevent vacuum leaks and to avoid causing damage to the throttle body. A carburetor that has been damaged due to negligence of the owner will void the warranty.

NOTE: Fuel line must be modified or a new fuel line must be installed due to increased center-center distance on the fuel bowl inlets. This carburetor is supplied with -6AN fuel inlet fittings. The inlet machining for the **HOLLEY ALUMINUM ULTRA XP** fuel bowls is SAE -8 port straight o-ring ($\frac{3}{4}$ "-16).

3. Connect the fuel lines, throttle linkage, and return springs. Operate the linkage to ensure correct travel by fully opening and closing the throttle by hand, as well as with the accelerator pedal (with engine off).

STARTING:

1. Without operating the throttle, crank the engine. It may take 15 to 30 seconds of cranking to allow the fuel bowls of the carburetor to fill. If the engine does not start, stop cranking, open and close the throttle twice and crank again until the engine starts.

WARNING! DO NOT crank the engine for more than 15 seconds at a time. Cranking longer than 15 seconds can overheat the starter, resulting in premature starter failure.

2. After starting the engine, check the fuel lines and inlet fittings for possible fuel leaks.

WARNING! If any fuel leakage or weeping is detected, shut off the engine immediately, and wipe up any fuel. Locate the source of the leak and correct before proceeding any further.

TUNING AND ADJUSTMENT:

Before you begin to tune your carburetor for your particular vehicle, you must get a "feel" for your vehicle's performance, so that any changes you make (Good or Bad) will be readily apparent. Be patient and **make only one change at a time**, so that only that change can be fully analyzed. This cannot be overemphasized, as there are no "short-cuts" to peak performance. Recording each change and the resulting performance increase or decrease will provide you with a "Handbook" of how vehicle performance is affected by individual carburetor adjustments. This may be helpful in the future or on other applications.

FUEL LEVEL (FLOAT LEVEL) FOR ALUMINUM ULTRA XP SERIES:

The float(s) controls the fuel delivery, however if the float(s) are not properly adjusted a fuel starvation or a flooding effect could result.



Figure 1

1. For the mechanical fuel pump, remove the positive wire from the ignition coil (do not let this wire touch anything to prevent a short during cranking or KOEO [key on engine off]). Crank the engine over for 10 seconds to allow fuel bowls to fill. Reconnect the coil positive wire when finished. Electric fuel pumps let the fuel bowls fill in stages by turning the ignition on and then off. Let the fuel pump run for a few seconds at a time. If an oil pressure safety switch is being used, the customer will need to temporarily bypass the switch.
2. Start the vehicle.
3. The fuel level in the clear sight glass should be mid-level for correct float adjustment. Most likely, this will not need to be adjusted. See Figure 1.
4. If you do need to adjust this, loosen the lock screw and turn the adjusting nut **clockwise to lower** the fuel level and **counter-clockwise to raise** the fuel level. Use caution when making adjustments. Fuel will be under pressure and may leak out if lock screw is loosened excessively.
5. Tighten the lock screw while holding the adjustment nut. Make sure the fuel level is mid-level of the sight glass.
6. If fuel level is adjusted too high rev the engine a few times.

TIP: To lower the fuel in the secondary bowl manually, open the secondary throttle shaft slightly. This will allow the secondary side to supply fuel to the engine and drop the fuel level faster.

IDLE SPEED ADJUSTMENTS:

NOTE: Please read the following paragraph carefully before proceeding with idle speed adjustments.

Your new **HOLLEY ALUMINUM ULTRA XP** carburetor has been set up from the factory with optimized throttle plate positioning in relation to the transfer slots. If after installing the carburetor, you find the idle speed needs adjusting, it is recommended to adjust the idle speed utilizing the new Idle Bypass Valve. If the proper idle speed cannot be achieved using the Idle Bypass Valve, the curb idle screw(s) can then be adjusted.

IDLE BYPASS VALVE:

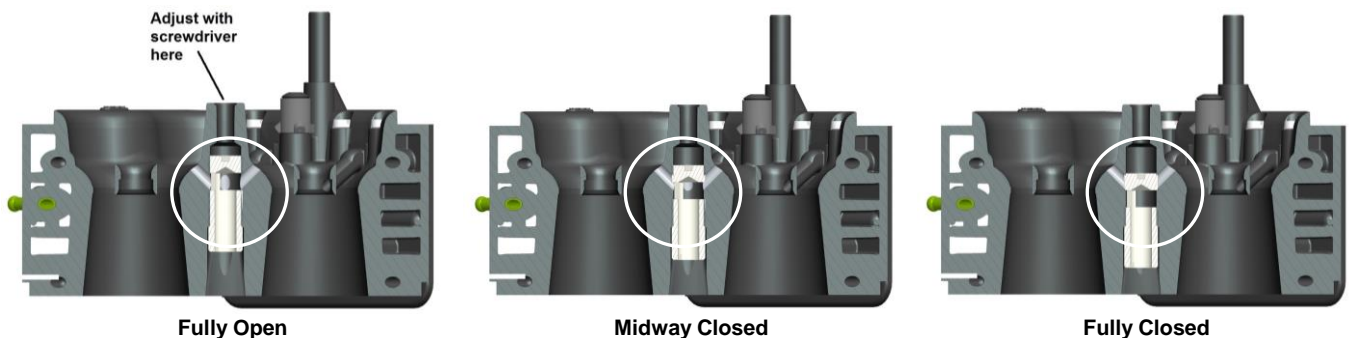

The idle bypass valve allows for additional airflow through the carburetor, while maintaining the desired relationship between the throttle plate and the transfer slot. Applications using a larger cam may benefit most from this new feature. This valve replaces the need for holes in the throttle plates.

1. Use the Holley XP screwdriver provided to finely tune your idle bypass circuit. This is a reversible screwdriver and you may need to flip it to the straight bit side.
2. The valve must be adjusted without the air cleaner stud in place. Insert driver down through stud hole and into slot on valve.
3. Turn clockwise to close off the idle bypass valve. This moves the valve down in the passage and begins to block the holes in the main body, therefore reducing idle RPM. Turning the valve counter-clockwise will increase airflow through the bypass valve, continue to adjust valve to obtain the desired engine idle RPM.
4. To see the position of the idle bypass valve, look in the drilled hole passages in the air cleaner boss on the main body.

IDLE SPEED SCREW(S):

The idle speed screw controls the throttle plate position at idle, which in turn raises or lowers the engine RPM. Again, the **HOLLEY ALUMINUM ULTRA XP** utilizes an Idle Bypass Valve and all idle speed adjustments should be attempted using the Idle Bypass Valve before changing the idle speed screws.

1. Start the engine and allow it to warm up.
2. Connect a tachometer, if your vehicle is not equipped with one.
3. Make sure the parking brake is on and the wheels are blocked. Place the automatic transmission in drive, the manual transmission in neutral.
4. If the idle speed is lower than desired, turn the screw clockwise to speed up the rpm. If the idle speed is higher than desired, turn the idle screw counter-clockwise to lower the rpm. This adjustment should be made to both the primary and secondary screws in equal amounts, so that the throttle plates are opened the same amount.

NOTE: The HOLLEY ALUMINUM ULTRA XP includes the secondary idle adjustment lever that allows the secondary throttle plate(s) to be adjusted without carburetor removal.

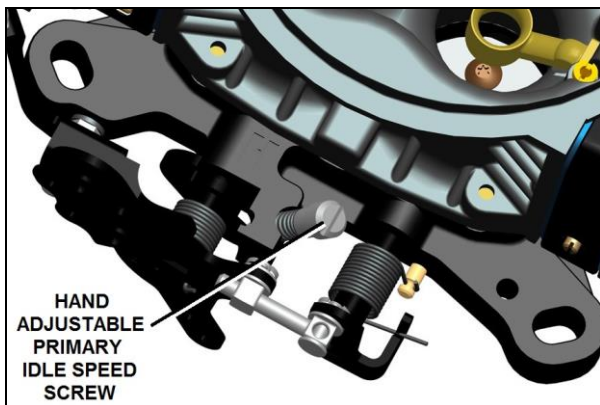

Figure 2

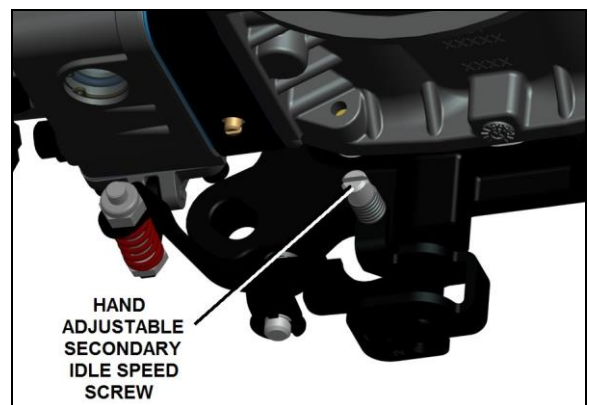

Figure 3

IDLE MIXTURE SCREWS:

Your carburetor will have four idle mixture screws; one for each venturi. This is known as four-corner idle. If you change one idle mixture screw, you should change the other idle mixture screws the same amount. Here are the proper steps for setting the idle mixture screws.

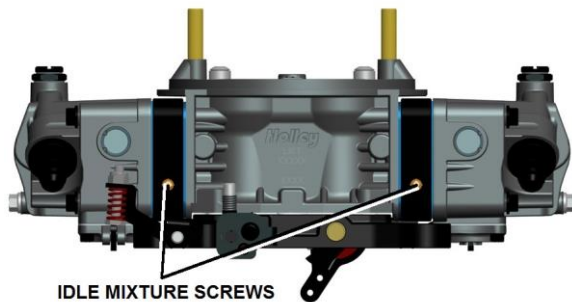

Figure 4A

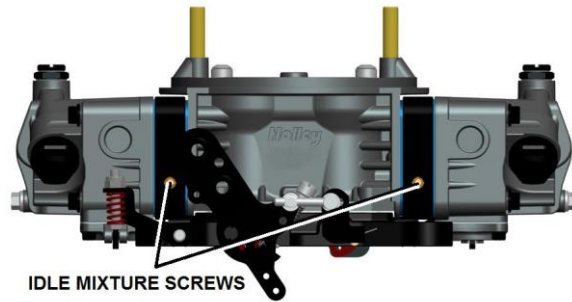

Figure 4B

1. First get the engine up to temperature.
2. With the engine off, install a vacuum gauge on a full manifold vacuum port. If a full manifold vacuum port is unavailable, you may tune to the highest idle RPM utilizing a tachometer.
3. Next, screw the idle mixture screws in all the way and then back them out $\frac{3}{4}$ of a turn.
4. Restart the engine (with the engine up to temp and @ idle) and adjust a mixture screw out $\frac{1}{8}$ turn at a time.
5. Continue to adjust each idle mixture screw the same amount to achieve the highest possible vacuum reading without increasing the idle speed screw.
6. Now that the idle mixture is set, it may be necessary to go back and reset the idle speed using the idle bypass screw. Continue back and forth between the tuning of the idle mixture screws and idle bypass screws, until little change is noticed in manifold vacuum and desired idle speed is achieved.

NOTE: Turning the mixture screws in leans the idle mixture, while turning them out richens the idle mixture.

ACCELERATOR PUMP:

The accelerator pump's purpose is to make up for the lag in fuel delivery. This enables the engine speed to increase in response to throttle opening. Differences in vehicle weight, transmissions, and rear axle ratios affect the amount of fuel and the delivery rate that should be provided by the accelerator pump. This may necessitate the customizing of your accelerator pump to your vehicle and its use.

NOTE: The old saying, "if a little is good, a lot is better", does not apply to the proper tuning of the accelerator pump. Your car's performance can be just as bad if it receives "too much fuel too soon", as if it receives "too little fuel too late."

Two factors that affect the accelerator pump's delivery are the pump cam and the pump shooter (discharge nozzle). The pump cam determines the total volume of fuel and affects delivery rate; the pump shooter affects delivery rate and helps determine the duration of the shot.

In general, the #1 locations on the pump cams provide a moderate initial delivery and have a greater final delivered volume. The #2 locations on the pump cams provide a greater initial delivery and have a lesser total delivered volume. The pump shooters have a number stamped on their casting, which designates the shooter size in thousandths of an inch, i.e., a #25 shooter has a .025" discharge orifice. The smaller diameter nozzles lengthen the pump shot duration and are used with heavier vehicles or with vehicles equipped with lower numerical rear axle ratios. Larger diameter nozzles (.035 - .037) shorten the pump shot duration, but deliver a greater initial volume of fuel. These sizes should be used on applications where engine speed will increase rapidly (vehicles with good power-to-weight ratios). Best acceleration is achieved when the accelerator pump delivers the lean, best-power, air/fuel ratio to the engine; not when the maximum volume of fuel is supplied.

An important point should be kept in mind when tuning an **HOLLEY ALUMINUM ULTRA XP**; the secondary accelerator pump must supply fuel for a sufficient time, so that the secondary main nozzles can "start up" and deliver fuel to the engine after the secondary throttle plates are opened. If the nozzles do not start by the time the pump shot expires, bogging will result. To apply the information above, follow these steps for tuning the accelerator pump.

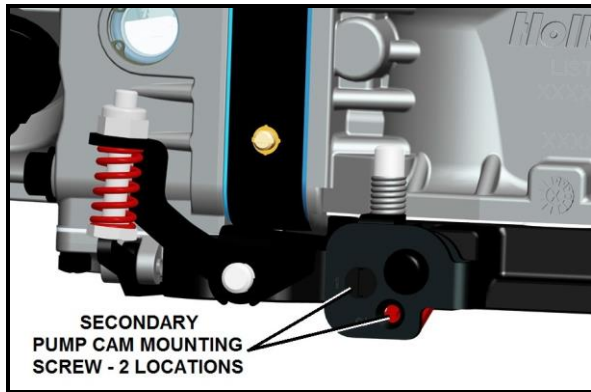

Figure 5

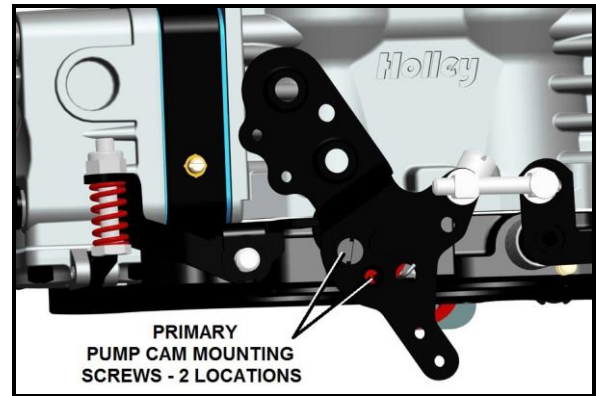

Figure 6

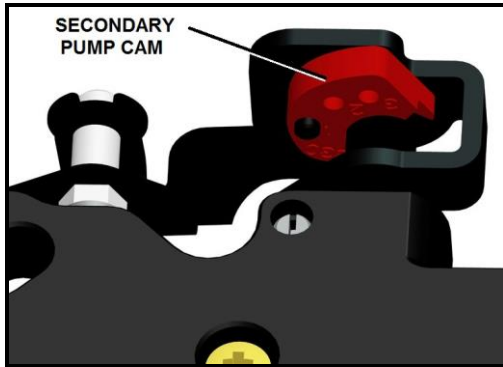

Figure 7

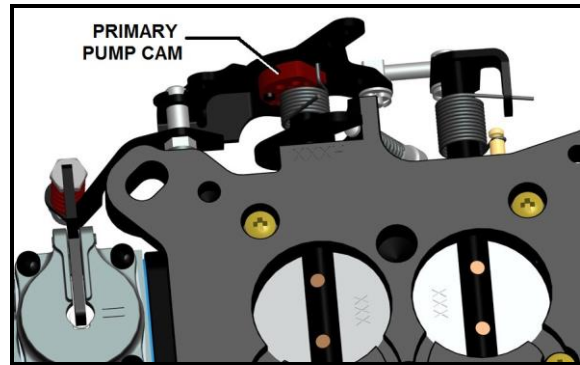

Figure 8

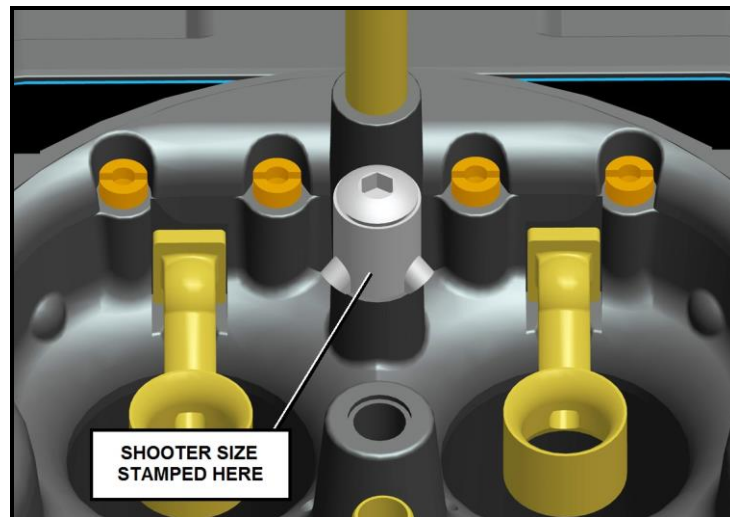

Figure 9

1. Change pump shooters, until the smallest diameter nozzle that provides the crispest response is found.
2. Then change the pump cams and locations until the right cam is found that provides better response.
3. Finally, change the pump shooter once again, until the crisp response is maximized.

NOTE: If a nozzle size is desired that seems “in between” the nozzle sizes provided, then the nozzle can be drilled to the desired size by using a wire drill held in a pin vise.

NOTE: This HOLLEY ALUMINUM ULTRA XP series carburetor is equipped with hollow pump screws, which must be used for proper function of the accelerator pump in this carburetor.

4. At this point, there should be no bogs, flat spots or black smoke (indicating excessive richness) when accelerating at wide open throttle from a standing start.

JETTING (MAIN JETS):

Due to varied applications that a universal performance carburetor will work with, no additional tuning jets have been included. However, a few tips on jetting are provided to help you understand their purpose.

NOTE: This carburetor is equipped with drain plugs on both bowls to make jet changes quicker and easier. Please use appropriate fuel collection device and procedures.

- Out of the box jetting is extremely close for most applications.
- In most cases, it will be unnecessary to increase jet size more than four numbers greater than out of the box jetting. However, exceptions could arise when the carburetor is mounted on a very large volume, tunnel-ram manifold.
- Carburetors are calibrated at 70° at sea level. Decrease the jet size one number for approximately every 2000 ft. increase in altitude. Increase jet size one number for every 35° drop in temperature.
- Holley jets are broached, flowed and stamped according to flow rate. **Never drill jets**, this seriously alters flow characteristics. Stamped numbers are reference flow numbers and **DO NOT** indicate drill size.
- Spark plugs provide the best indication of proper jetting, provided that they are read correctly.

TUNABLE METERING BLOCK:

IMPORTANT! It is recommended that you document the existing adjustable bleed sizes that make up this metering block **BEFORE** any changes are made. This billet adjustable metering block allows the user to tune the idle feed restrictions, emulsion bleed restrictions, power valve, power valve channel restrictions, and main jets.

IMPORTANT! Holley highly recommends that only an experienced carburetor tuner [with access to a dynamometer that monitors air/fuel ratio and BSFC (Brake Specific Fuel Consumption)] make any changes to the factory restrictor settings, as received from Holley. Furthermore, Holley is not responsible for any engine damage that may occur due to the carburetor being changed from the original factory calibration.

Power Valves:

The number etched into the face of the power valve indicates the manifold vacuum below which the power valve is operational. In this case, all manifold vacuums below 6.5" Hg., the power valve is operating. Generally, a 65 power valve is sufficient for most high performance applications that have a manifold vacuum of 12" Hg or higher. However, some problems can result with radically cammed, full-race machines equipped with automatic transmissions. These vehicles often "idle" at 2000 rpm, approx. 6.0" Hg. At this point, the main nozzles are starting to feed and richen the mixture (supplied by the power valve) and the engine will probably "load up". To correct this problem, install a 45 or 35 power valve. If the engine has a manifold vacuum of 12" Hg or less, a good way to determine power valve size is take the manifold vacuum at idle and divide that number by two. The answer is the power valve size. This will provide idling and proper fuel flow under wide-open throttle conditions when manifold vacuums seldom rise above 1" Hg.

NOTE: Some carburetors come equipped from the factory with plugs in the secondary metering block. These are generally carburetors set up for 2 x 4 calibrations.

Power Valve Channel Restrictions (PVCR):

These two restrictions are visible when the power valve is removed. They meter the flow of fuel into the main well. It is the PVCR diameter, not the openings in the power valve, which controls the amount of fuel admitted in the circuit. Changing the size of these restrictions will lean/enrich the air/fuel ratio at full power, but will have no effect at idle or during part throttle operation, when the power valve is closed.

Idle Feed Restrictions (IFR):

The idle circuit calibration is determined by the diameter of the IFR and the idle air bleed. An IFR is nothing more than a metering jet for the idle system and the air bleed serves as an air/flow-regulating orifice. Turning the idle mixture screw varies the **volume** of air/fuel emulsion discharged into the manifold, not the ratio of air to fuel in the emulsion. Typically, as camshaft duration and overlap are increased, idle fuel jetting (idle feed restriction size) must be correspondingly increased to compensate for dilution and scavenging (where an amount of intake charge is drawn out through a late closing exhaust valve).

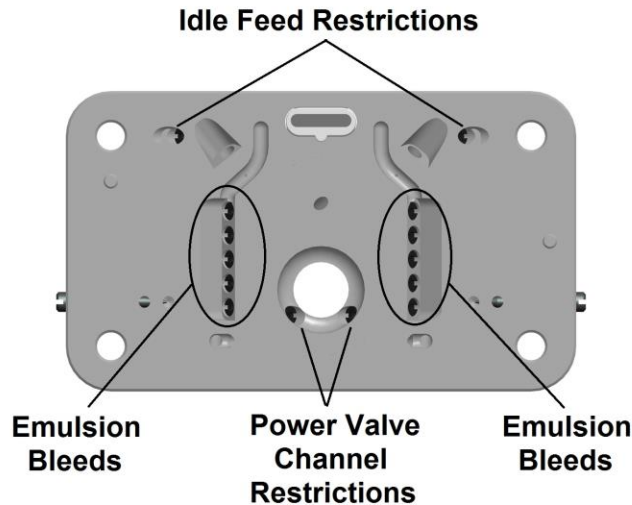

**2 Circuit Billet Metering Block (Front) Model 4150 ALUMINUM XP Series
Figure 10**

Emulsion Bleeds:

The emulsion bleeds are best tuned on the dynamometer. Bleed utilization (size and location) can vary, as will horsepower gains, depending upon the engine. Not all of the emulsion bleed holes have to be used to obtain peak performance. Gains have been documented on use of as little as three (one side of metering block) of the bleed holes.

NOTE: The emulsion bleed tuning kit (P/N 36-322) will support tuning of this metering block. It contains ten each of the following bleed sizes: Blank (no hole), .020", .031", .040", .046", and .052". Bleeds are available from blanks to .082" from your Holley dealer under individual P/Ns 142-xx (xx=size) sold in pairs.

AIR BLEEDS:

WARNING! Adjustment of the air bleeds is not recommended. A competent tuner with a complete and thorough knowledge of carburetors, fuel systems, and engine requirements should only perform air bleed adjustments. Failure to follow these recommendations may result in a lean fuel/air mixture causing severe engine damage, property damage, serious injury, and/or death.

WARNING! Air bleed sizes should not be adjusted more than six (6) sizes in any one direction from the original air bleeds, as shipped from Holley. Air bleed adjustment beyond six (6) sizes could result in a lean fuel/air mixture causing severe engine damage, property damage, serious injury, and/or death.

Experimenting with air bleeds is not recommended and should only be attempted by an expert carb tuner. Countless hours of flow testing have been performed to obtain the proper bleed size for a given calibration. It is unlikely that a better air bleed calibration can be obtained, however the **HOLLEY ALUMINUM ULTRA XP Series** are equipped with removable air bleeds. Here is some basic knowledge of how air bleeds work.

The main or high-speed air bleeds affect the entire range of the main-metering system. The purpose of the main metering system and main air bleeds is to emulsify the fuel before entering the booster to be discharged into the air stream in the venturi. The fuel/air mixture becomes leaner as air bleed size is increased. Decreasing the size of the main air bleeds will decrease pressure across the main jet, which in turn will pull more fuel through the main system creating a richer fuel/air mixture. The main or high speed air bleeds also act as an anti-siphon or siphon breaker, so fuel does not continue to discharge or dribble into the venturi after airflow is reduced or stopped. At high speeds, the fuel/air mixture must be on the rich side to prevent damage to the engine.

The idle system supplies fuel at idle and low speeds. The idle system requires a richer mixture than at cruise speed. Unless the idle mixture is richer, a slow and irregular combustion will occur, known as a rough idle. Decreasing the idle air bleed size richens the idle mixture by increasing the pressure drop in the system. Increasing idle air bleed size leans the idle mixture by reducing the pressure drop across the idle air bleeds. The same conditions can be created by backing out the idle mixture screws, which will increase the pressure across the idle air bleeds, pushing more fuel from the idle well creating a richer fuel/air ratio. The idle mixture screw is the only adjustment recommended for controlling the idle fuel/air mixture richness or leanness.

NOTE: See Figure 11 for air bleed locations and identification. It is recommended that all jet sizes be documented before any tuning of the air bleeds or main jets is started. Below is a chart for recording the jet and air bleed sizes for your HOLLEY ALUMINUM ULTRA XP Series carburetor, as shipped from Holley. Should you adjust the air bleed size or main jet size, this chart will allow the tuner to return the carburetor to the original jetting. Please place this information in a safe place along with any other documentation for your carburetor.

IFR			
PVCR			
POWER VALVE			
EMULSION BLEEDS			
BLEED 1			
BLEED 2			
BLEED 3			
BLEED 4			
BLEED 5			
JET			
IAB			
HSB			
SQUIRTER			

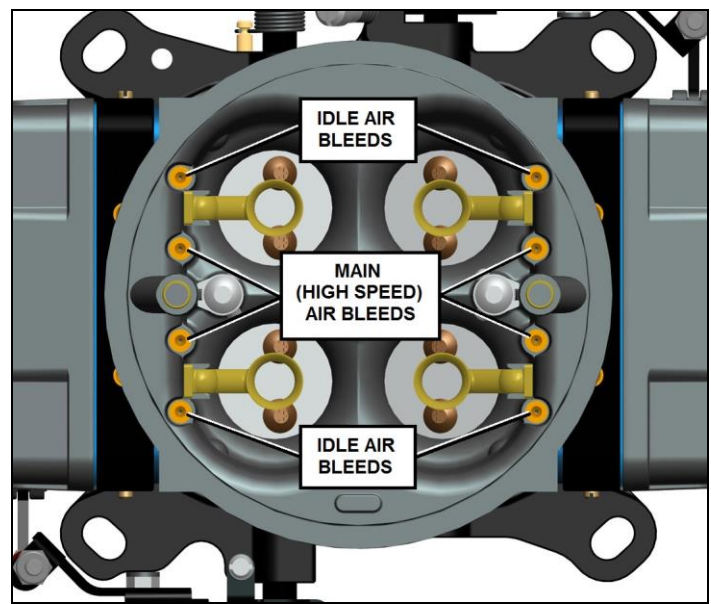

Figure 11

SECONDARY MAIN JET EXTENSIONS:

Main jet extensions can be used in the secondary jets to prevent the secondary main jets from being uncovered as fuel rushes to the back of the fuel bowl during extreme accelerations.

ADJUSTABLE THROTTLE LINKAGE:

The **HOLLEY ALUMINUM ULTRA XP** carburetor features a user adjustable secondary throttle link. From Holley, the link is set-up for progressive throttle activation. It can also be adjusted to obtain 1:1 throttle activation. If adjustment is desired, please follow the steps below:

1. Remove the two cotter pins. Then, remove the washers making sure not to mix them up as they will need to go back in the same place.
2. Remove the secondary link.
3. For 1:1 operation, the link will need to be installed into the hole of the throttle lever closest to the throttle shaft (See Figure 12)
4. Hold the primary and secondary throttle shaft to wide open throttle. Adjust the link to the proper length so it fits easily into the proper hole on the primary shaft and into the secondary shaft.
5. Re-install the washers and secure the cotter pins.
6. Cycle the throttle several times to ensure it is going to wide open throttle and to a fully closed position without binding or sticking, If the throttle does not go to full open or closed position, adjustments to the length of the link may be necessary.

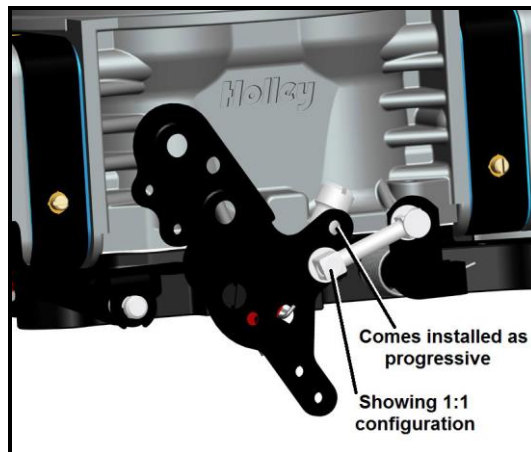

Figure 12

Holley Performance Products
Toll Free Technical Service: 1-866-464-6553
Technical Service: 1-270-781-9741
For online help, please refer to the Technical Information section of our website:
www.holley.com

© 2011 Holley Performance Products, Inc. All rights reserved.

199R10565-1
Revision Date: 8-15-16