



P/N 534-224 – Holley LS Hi-Ram Fuel Rail Adapter Kit for LS7 Fuel Injectors

Contents:

Fuel Rail, qty-2
Spacer, Fuel Rail, qty-4
Washer, 1/4 AN Stainless Steel, qty-4
Socket Head Capscrew, 1/4-20 x 1.75" Long, qty-4
O-Ring, Fuel Injector to Intake Manifold Seal, qty-8

INSTALLATION INSTRUCTIONS

(Before installation, please read these instructions completely.)

1. The provided O-rings are for use with GM LS7 style fuel injectors. If using GM LS7 injectors, remove the O-ring from the outlet end of each injector and replace with the O-ring provided in this kit. If using Bosch EV-1 style injectors, the provided O-rings are not needed.
2. Apply a silicone lubricant to the fuel injector outlet O-rings and the intake manifold fuel injector ports. Insert the injectors into the intake manifold fuel injectors ports being careful to not to cut the O-ring.
3. Apply a silicone lubricant to the fuel injector inlet O-rings and the fuel rail injector ports. On each bank, place the fuel rail on the four injectors and gently push down until each of the four injectors is inserted into the fuel rail. Be careful not to cut any of the O-rings.
4. Make sure all of the fuel injectors are free to move rotationally on the O-rings and not are being bound by insufficient space between the fuel rail and intake manifold ports. Also check that the fuel injectors are properly captured so that there is no way the injector can move axially far enough to have the O-ring come out of the fuel rail port and leak high pressure fuel.
5. Once the fuel plumbing is installed, run the fuel pumps to pressurize the fuel system and ensure that there are no fuel leaks before operating the engine.

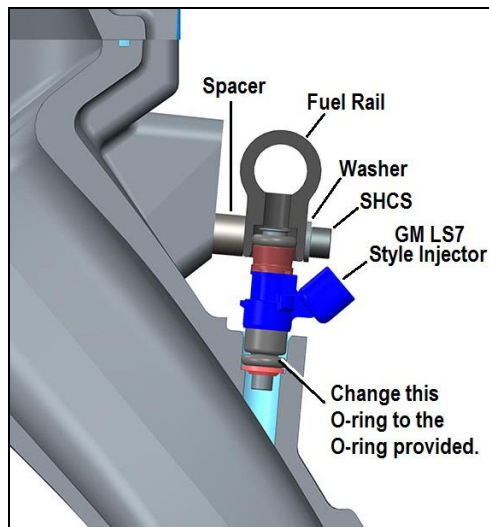

Technical Support: 1-866-464-6553

© Holley Performance Products, Inc.

199R10921

Date: 10-14-15