



MARINE AVENGER™ CARBURETOR

0-82570 – 570 CFM Marine Avenger

0-82670 – 670 CFM Marine Avenger

0-82770 – 770 CFM Marine Avenger

INSTALLATION, TUNING, AND ADJUSTMENT MANUAL

199R11075

NOTICE: For safety and protection of persons and property, all United States Coast Guard (U.S.C.G.) and other marine safety requirements and recommendations, as well as the following instructions, must be carefully studied and applied.

Failure to follow the above WILL result in an improper installation, which may lead to personal injury, including death, and/or property damage. Improper installation and/or use will also void your warranty.

WARNING! For the safety and protection of yourself and others, ONLY a trained mechanic, having adequate marine fuel system experience, must perform the installation, adjustment, and repair. It is particularly important to remember one of the very basic principles of marine safety: fuel vapors are heavier than air and tend to collect in lower places. This means that ANY fuel spilled will vaporize and remain in the lowest extremes of the engine compartment of your vessel, where an explosive fuel/air mixture may be ignited by any spark or flame. Great care must be exercised to prevent spillage and thus eliminate the formation of such fuel vapors. In all cases, it is necessary to have and properly operate the bilge blower for a sufficient length of time to remove all vapors before starting your vessel's engine.

NOTE: Due to the large distance between the helm and the engine in most boats, it is STRONGLY recommended that the mechanic have an assistant to operate the appropriate helm controls during removal, installation, adjustment, repair, and the starting procedure of the marine fuel system.

NOTE: These instructions must be read and fully understood before beginning installation. If this manual is not fully understood, installation should not be attempted. Failure to follow these instructions, including the pictures may result in subsequent system failure.

TABLE OF CONTENTS:

INTRODUCTION:	2
REMOVAL:	2
INSTALLATION:	3
STARTING:	4
CHOKE CONNECTION:	4
CHOKE ADJUSTMENT:	5
FUEL SYSTEM STORAGE INSTRUCTIONS:	5
IDLE MIXTURE NEEDLES:	5
FLOAT LEVEL ADJUSTMENT:	6
VACUUM OPERATED SECONDARY THROTTLES:	7
VACUUM OPERATED SECONDARY TUNING:	7
JETTING (MAIN JETS):	9
HOLLEY® MARINE AVENGER™ LIMITED LIFETIME WARRANTY	10

INTRODUCTION:

CONGRATULATIONS on your purchase of the Marine Avenger™ Carburetor! We feel that you have purchased the finest Marine performance carburetor manufactured today. Should you need information or parts assistance, please contact our Technical Service Department at **1-866-464-6553**. Please have the part number and sales receipt ready when calling.

IMPORTANT: The **MARINE AVENGER™** carburetor has been factory wet-flowed and calibrated. The “out of the box” settings should be very close for all adjustments.

To preserve warranty, these instructions must be read and followed thoroughly before and during installation.

These carburetors have been designed and calibrated as a universal replacement carburetor for marine applications equipped with V-6 and V-8 engines. It is designed for use on “square” flange intake manifolds. Carburetor adapters are not recommended to adapt to “spread” bore intake manifolds, since adapters may have an adverse effect on cylinder-to-cylinder distribution and ultimately, total engine performance. However, some manifolds may be universal (such as Weiland 8004). Please check with Holley’s Technical Service Department if you have any questions.

REMOVAL:

WARNING! The following steps **MUST** be carefully studied and applied when disconnecting ANY part of the fuel system.

1. Disconnect the battery (to prevent accidental arcing) and any other equipment, which may or can cause arcing. Extinguish ANY flame!



NO SMOKING!

2. Label and remove all hoses going to the flame arrestor.
3. Remove the flame arrestor.
4. Remove the existing carburetor following the procedure outlined below:
 - A. Carefully disconnect the fuel line. Catch all fuel left in the fuel line in a suitable container and REMOVE the container from the vessel before proceeding further. Absorb any spilled fuel immediately with a shop towel or rag and remove from the vessel.

- B. Label and disconnect all vacuum lines attached to the carburetor.
- C. Disconnect any choke rods, heat tubes, and any electrical wires from the carburetor.
- D. Disconnect and remove the throttle linkage. Save all retaining clips.
- E. Unbolt the carburetor and remove.

WARNING! Be EXTREMELY careful not to tilt the carburetor, which may cause fuel to spill. REMOVE the carburetor from the vessel. If fuel spillage occurs, see instructions 4A above.

- F. Stuff shop rags or paper towels into the manifold opening and remove the original flange gasket. Clean the manifold face, taking precautions to prevent particles from falling into the manifold.
- G. Perform any carburetor disassembly, service, and reassembly off the vessel.

INSTALLATION:

1. Remove the shop rags or towels from the manifold opening.
2. Install the carburetor-mounting studs in the proper location on the intake manifold carburetor flange.
3. Place the new carburetor flange gasket, provided with the carburetor, in the proper position on the intake manifold.
4. Place the carburetor on top of the flange gasket on the manifold. Install the hold down nuts and snug down progressively in a "crisscross" pattern (60-80 in./lbs.), as shown in **Figure 1**.

WARNING! After re-assembly, check the throttle linkage for sticking and/or binding. Be sure that there is no interference between parts as the throttle lever is operated from idle to full wide-open throttle positions.

5. Check for sticking by having the assistant at the helm operate the throttle controls while the experienced mechanic watches the operation of the carburetor(s) to detect any malfunctions.
6. If any binding, sticking, or malfunction is found, it MUST be corrected before proceeding further.
7. Recheck to ensure that all existing vacuum hoses are attached properly. Plug any ports not used.
8. Reinstall the flame arrestor and reconnect all the hoses and fuel lines.
9. Open all hatches and allow the bilge to ventilate naturally until no fuel vapors are present.
10. Reconnect the battery and operate the bilge blower for a minimum of ten minutes.

WARNING! The bilge blower should be operated until ALL fumes have been safely expelled from the bilge area. The blower should be run for at least ten minutes or longer, if necessary.

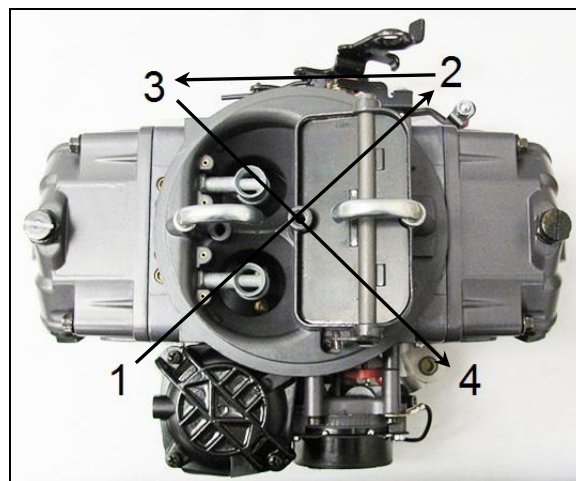

Front of Engine

Figure 1

WARNING: Overtightening may result in warped or cracked carburetor throttle body.

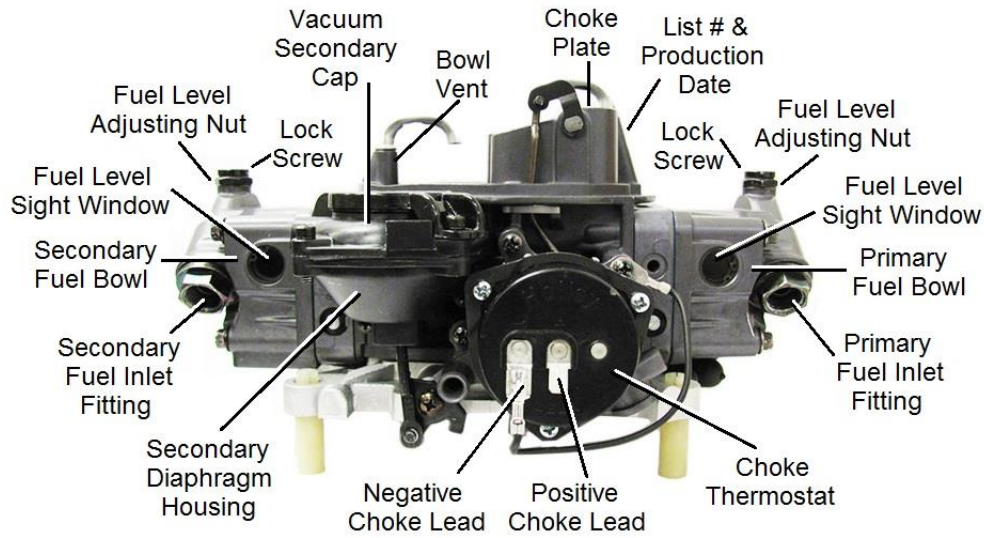

Figure 2

STARTING:

1. Without operating the throttle, crank the engine. It may take 15 to 30 seconds of cranking to allow the fuel bowls of the carburetor to fill. If the engine does not start, stop cranking, open and close the throttle twice, and crank again until the engine starts.

WARNING! After starting the engine, check the fuel lines and inlet fittings for possible leaks. If ANY fuel leakage or weeping is detected, shut off the engine immediately. Wipe any leaked fuel up and remove the rag or towel from the vessel. Operate the bilge blower as directed above before proceeding to correct the cause of the leakage. Be sure to operate the blower again before attempting to restart the engine.

CHOKE CONNECTION:

1. For choke hookup, attach the bayonet end of the long electrical lead supplied to the positive terminal on the choke cap. **The other end must be connected to an ignition-activated 12-volt source.** The distributor side of the ignition coil is **NOT** a 12-volt source. It is a 7-9-volt source after cranking. The shorter wire and terminal assembly provided is for the choke ground. Connect the bayonet end of the wire and terminal assembly to the negative side of the choke cap. Connect the round terminal end to a good ground. The choke housing screws or the secondary diaphragm housing screws can be used for this.

WARNING: Connecting the choke cap to the ignition or ignition coil could result in unacceptable choke operation, poor fuel economy, and possible engine misfiring, since the voltage delivered to the spark plugs will be severely reduced by the drain imposed by the choke cap. Suitable ignition-activated 12-volt sources are most electrical relays, as well as the leads to the accessories, such as windshield wipers. **DO NOT** connect this wire to the original equipment (O.E.) electric choke source. This may not be a 12V source.

NOTE: Check the voltage source with a volt-ohm meter to ensure proper voltage and choke operation.

CHOKE ADJUSTMENT:

1. You can control the choke operation by rotating the choke cap. Loosen the screws. If the choke comes off too soon, rotate the cap counterclockwise one notch at a time, and retighten the screws until the choke operation is satisfactory. On the other hand, if the choke comes off too late, loosen the screws and rotate the cap clockwise. Tighten the screws. The choke setting from the factory is on "index" or at the center position. After making the final adjustments, start the engine and make sure the choke plate opens completely.
 - A. A choke that comes off too soon could exhibit one or more of the following symptoms: stalling, surging, backfiring, stumbles, or poor vessel drivability when the vessel is cold.
 - B. A choke that comes off too late could exhibit one or more of the following symptoms: black smoke from the exhaust pipes, poor drivability when cold, poor fuel economy, misses, or rough idle.
2. From the factory, the choke cap has built-in limiters. If choke operation is unsatisfactory and you have adjusted the choke cap in either direction to the limiters with unsatisfactory results, recheck your positive electrical line connection.

FUEL SYSTEM STORAGE INSTRUCTIONS:

During extended periods of vessel storage (60 days or more), gasoline may deteriorate due to oxidation. This can damage rubber and other polymers in the fuel system. It may also clog small orifices such as main jets, idle feed restrictions, and power valve channel restrictions. A commercially available fuel stabilizer such as STA-BIL or an equivalent should be added to the vessel's fuel tank whenever actual or expected storage periods exceed 60 days.

Follow the product instructions for the amount of additive to use. The engine should be operated at idle for a minimum of ten minutes after the addition of the stabilizer to assure that it reaches the carburetor.

IDLE MIXTURE NEEDLES:

Idle mixture needles control the air/fuel mixture at idle. These have been preset at the factory and SHOULD NOT need any adjustments. However, if you feel that adjustment is necessary, you can use the following procedure to do so. When tuning the idle mixture, you're actually tuning for the best manifold vacuum. Idle mixture needles are found on the primary metering blocks. **(Marine Avengers™ have 4 corner idle which means there are mixture screws in the front and rear metering blocks)** If you change one idle mixture needle, you should change the other idle mixture needle(s) by the same amount. Here are the proper steps for setting the idle mixture needles.

1. Attach the vacuum gauge to a manifold vacuum port on the throttle body (**Figure 3**).
2. Adjust each idle mixture screw (**Figures 5 & 6**) 1/8 turn at a time, alternating between each screw. Turn them equally, until you achieve the highest possible vacuum reading without adjusting the curb idle speed screw. Turn screws in to decrease the idle fuel mixture. Turn them out to increase the idle fuel mixture.

NOTE: If a vacuum gauge is not available, use a tachometer to obtain the highest RPM.

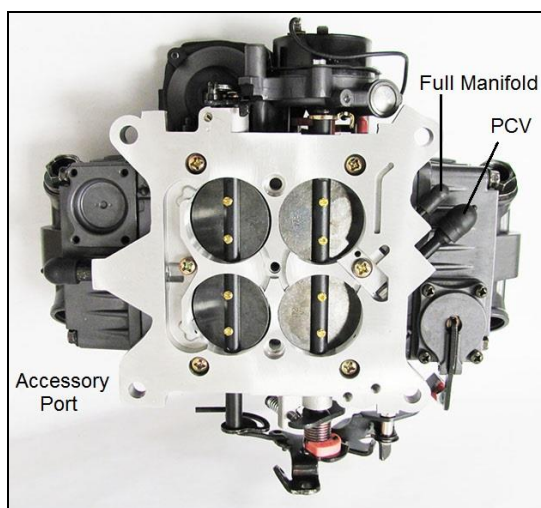

Figure 3

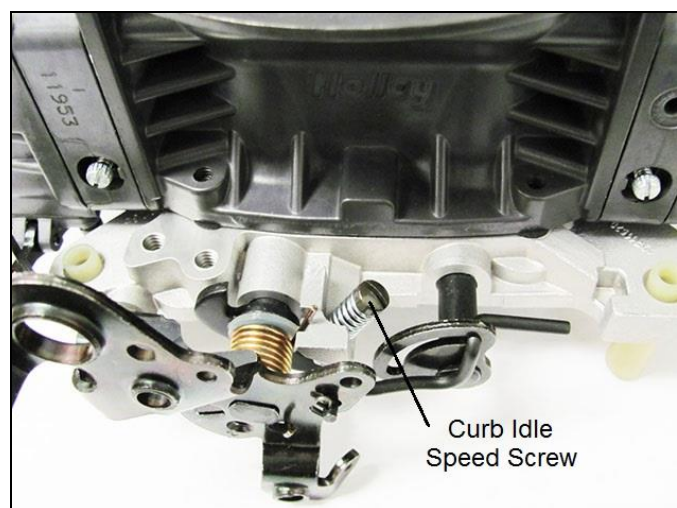

Figure 4

- Now that the idle mixture is set, it may be necessary to go back and reset the idle speed using the curb idle speed screw, as shown in **Figure 4**.

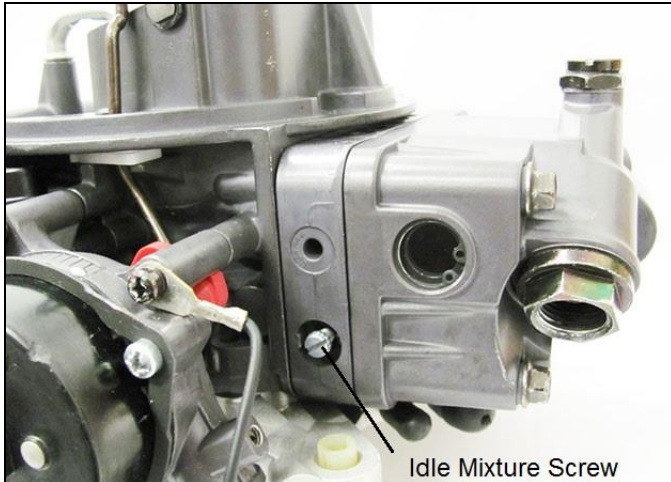

Figure 5

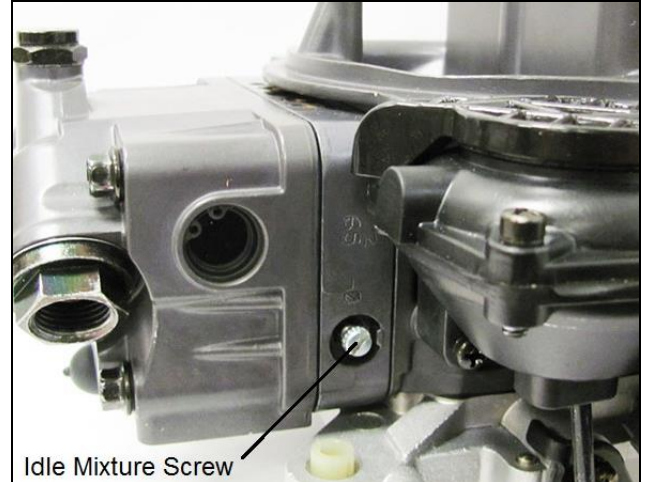

Figure 6

ROUGH IDLE AND VACUUM LEAKS: If a rough idle persists after the engine has been started and the mixture screws adjusted, check for vacuum leaks. These could result from unplugged vacuum ports or a carburetor flange gasket that was torn during installation. Recheck for proper attachment of all vacuum lines and check the lines for cracks.

If the manifold was changed, a manifold vacuum leak could occur at the cylinder head/manifold surface due to damaged gaskets or improper torquing. Frequently, manifold vacuum leaks occur from the valley side of the manifold. These are very difficult to detect, unless a discernible whistle can be heard.

NOTE: In most cases, when rough idle occurs after a carburetor/manifold change, they result from manifold vacuum leaks similar to those described above. Assuring a proper manifold installation rather than assuming the carburetor is not functioning properly will ultimately save time.

FLOAT LEVEL ADJUSTMENT:

WARNING! Absorb any spilled fuel immediately with a shop towel or rag and remove from the vessel. The bilge blower should be operated until ALL fumes have been safely expelled from the bilge area. The blower should be run for at least ten minutes or longer, if necessary.

NOTE: Do not try to remove either sight glass. It takes special tools to install these and it is not recommended that they be removed.

Primary and secondary float adjustments are set at the factory, but variations in fuel pressure could cause a change in these settings. Recommended fuel pressure should be in the range of 4 – 6 PSI. To aid in adjustment of the float levels, clear sight windows are installed from the factory. The following procedure shows how to make these adjustments:

- Start the vehicle.
- Observe the sight glass for the fuel level. If none is seen, the level is too low. If it is higher than the middle of the sight window, it is too high. **NOTE:** A properly set float level will have the fuel level located at the middle or slightly below the middle of the sight window, as shown by the line in **Figure 7**.

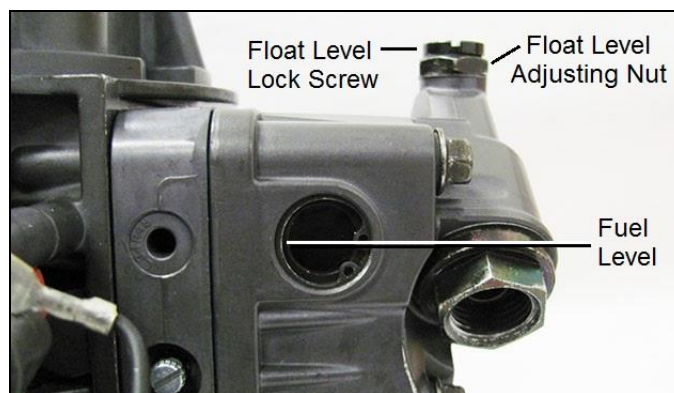

Figure 7

3. To adjust, shut down the engine.
4. Loosen the lock screw on top of the fuel bowl just enough to allow you to turn the adjusting nut. Hold the screw in position with the screwdriver.
5. Using a 5/8" wrench, turn the adjusting nut in the appropriate direction: **Clockwise to lower float and counterclockwise to raise float.**

NOTE: Many customers attempt to adjust the float level down by turning the adjusting nut clockwise, only to see the fuel level rise through the sight glass. This is due to the float being pushed down into the fuel, therefore displacing the fuel to a higher level. You will find it easier to adjust the float levels, if you rev the engine slightly between adjustments to evacuate the fuel.

6. Turn the adjusting nut in increments of 1/4 of a rotation.
7. Retighten the lock screw.
8. Restart the vehicle and observe the sight window.
9. Repeat steps 1 through 8 as necessary.

SECONDARY FLOAT LEVELS:

Very little fuel is drawn out of the secondary fuel bowls during idle operation. This makes it a little tricky to set the proper float level with the sight glasses. Many customers attempt to adjust the rear float level down by turning the adjusting nut clockwise, only to see the fuel level rise through the sight glass. This is due to the float being pushed down into the fuel, therefore displacing the fuel to a higher level. You will find it easier to adjust the float levels, if you rev the engine slightly by opening the secondaries between adjustments. This can be easily done by pushing upward on the secondary diaphragm stem or by rolling the secondary throttle shaft linkage forward on the driver's side of the vehicle. This will use fuel from the secondary bowl at a much faster rate, allowing the float level to seek the adjustment point that you have set. Once the floats have been set with this procedure, drive the vehicle, making sure the secondaries open and recheck the float level.

VACUUM OPERATED SECONDARY THROTTLE PLATES:

Many people have the misconception that opening the secondary throttle plates sooner will provide increased performance. Others think they must "feel" a kick when the secondaries engage. Still others believe that they should disconnect the vacuum diaphragm and make the secondaries open mechanically.

Before going any further, let's discuss these points in a reverse order. First, if we could make our vacuum operated secondary carburetors perform better by opening the secondaries mechanically, it would be to our advantage to do so since all that vacuum actuating hardware is expensive and requires much time and money to calibrate. Mechanical secondary carburetors all utilize a secondary pump shot to prevent bogging when the secondaries are opened. Secondly, those who "feel" a kick when the secondaries engage are actually feeling a flat spot during initial acceleration because the secondaries have already begun to open and have weakened the fuel delivery signal to the primary boosters. The engine is struggling to increase speed and what they actually feel are the secondary nozzles "crashing in" as the engine finally reaches the speed where it provides the proper fuel delivery signal to primary and secondary venturi. Third, opening the secondaries early causes the situation described above. The secondaries must not open until the engine requires the additional air. This allows torque to increase along the peak torque curve. Performance is compromised less by holding the secondaries closed a little longer than by opening them a little too soon. If the opening rate of the vacuum operated secondaries is properly calibrated there should not be a "kick", only a smooth increase in power should be felt.

VACUUM OPERATED SECONDARY TUNING:

The secondaries will not open by free-revving the engine. The engine needs to be under a load before they will open. If you are still uncertain if they are opening, you can take a normal paperclip and clip it onto the secondary diaphragm rod and slide it up against the bottom of the secondary diaphragm housing. Go out and drive the vehicle, making sure to get into the secondaries. When you return you will be able to look at the position of the paperclip on the rod. If it is lower on the rod, you can tell the secondaries opened and how far they opened. This is useful in determining if you need a heavier or lighter secondary spring. Your Avenger product is shipped with two extra secondary springs to assist in tuning the secondary operation. One lighter and one heavier than what is currently calibrated. If you choose to change the spring, refer to the spring chart below and color reference on the small end of the spring to determine which spring you want to use.

Spring Description	Spring Identifier
Spring small end is coated Yellow	Softest
Spring small end is coated Red	Soft
Spring small end is plain	Medium
Spring small end is coated black	Stiff

1. Remove the flame arrestor assembly.
2. Remove the 2 Phillips screws from the black vacuum diaphragm spring cap.
3. Lift off the cap and spring. Remove the spring from the cap. Replace with a softer or stiffer spring (reference chart above).
4. The **softer** spring will allow the secondaries to open sooner (for lighter vehicles) and increase performance.
5. The **stiffer** spring will force the secondaries to open later (for heavier vehicles) and increase performance.



Figure 8

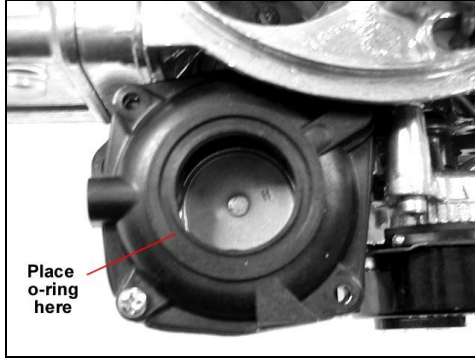

Figure 9

6. The spring that comes in the Marine Avenger™ Carburetor kit has been calibrated to give the best performance and fuel economy in most applications.
7. Once you have selected a spring, attach it to the cap (**Figure 8**) by placing the small end of the spring over the center post on the cap. Check the O-ring seal and place the cap and spring back into the vacuum diaphragm housing.

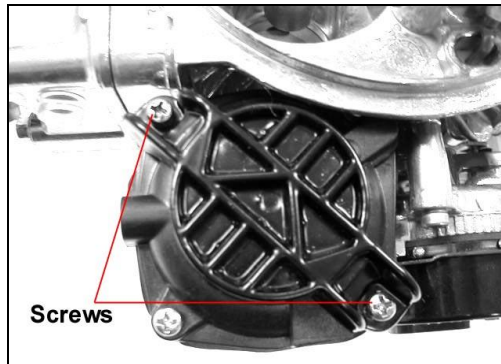

Figure 10

8. Tighten the two Phillips screws securely and reinstall the flame arrestor, as shown in **Figure 10**.
9. Test drive the vessel.

If you feel you want to test more spring options, Holley offers a secondary spring kit Part# 20-13 that carries some additional spring rates for further calibrating and tuning.

JETTING (MAIN JETS):

Due to varied applications that a universal performance carburetor will work with, a few tips on jetting are provided to help you understand their purpose.

1. Out of the box jetting is extremely close for most applications.
2. Carburetors are calibrated at sea level. Decrease the jet size primary and secondary, one number for every 2000 ft. increase in altitude.
3. Holley® jets are broached, flowed, and stamped according to flow rate. **NEVER** drill jets, as this seriously alters flow characteristics. Stamped numbers are reference numbers and **DO NOT** indicate the drill size.
4. In most cases it will be **unnecessary** to increase jet size more than four numbers greater than out of the box jetting. Exceptions could arise when the carburetor is mounted on a very large volume, plenum-ram manifold.
5. Spark plugs provide the best indication of proper jetting. Consult an ignition manual for proper reading of spark plugs.

HOLLEY® MARINE AVENGER™ LIMITED LIFETIME WARRANTY

Holley® Performance Products warrants its Holley® Marine Avenger™ Carburetor to be free from defects in material and workmanship for the life of the product on parts and one year on repair labor. After a period of one year, Holley® will charge standard rates for repair labor. For any Holley® Marine Avenger™ Carburetor used in any type racing or off-road use will only be covered by a one (1) year limited warranty on parts and labor. Warranty performance will be initiated by returning the alleged defective product to HOLLEY® PERFORMANCE PRODUCTS with the original, dated purchase receipt. Purchaser is to call toll free the Holley® Factory Service number at 1-866-464-6553 to receive details and shipping instructions.

Holley® Performance Products does not warrant products which have been (a) modified or altered outside factory specifications, (b) subjected to conditions such as abuse, misuse, neglect, accident, improper installation or adjustment, contaminants, water or corrosion, gum or varnish, use of improper or poor quality fuel or fuel additives, fire from a backfire, and faulty repair or (c) in other than those automotive applications recommended in a current Holley® catalog. Holley® shall not be responsible for (a) actual or alleged installation or removal labor, inbound shipment costs or other incidental charges or (b) actual or alleged incidental or consequential damages incurred by the use of a Holley® Marine Avenger™ Carburetor. Further, there are no warranties, which extend beyond those stated here.

This warranty is extended to the original consumer purchaser and has as duration the lifetime from date of original purchase by such consumer. **THIS WARRANTY IS EXPRESSLY IN LIEU OF ALL OTHER WARRANTIES EXPRESS OR IMPLIED INCLUDING, BUT NOT LIMITED TO, THE WARRANTIES OF MERCHANTABILITY AND FITNESS FOR A PARTICULAR PURPOSE AND ALL OTHER OBLIGATIONS OR LIABILITIES ON OUR PART. WE NEITHER ASSUME, NOR AUTHORIZE ANY OTHER PERSON TO ASSUME FOR US, ANY OTHER LIABILITY IN CONNECTION WITH THE SALE OF THIS MARINE AVENGER™ CARBURETOR. WE MAKE NO WARRANTY WHATSOEVER IN RESPECT TO ACCESSORIES OR PARTS NOT SUPPLIED BY US. AS USED IN THIS WARRANTY, "PURCHASER" SHALL BE DEEMED TO MEAN ONLY THAT PERSON FOR WHOM THE MARINE AVENGER™ CARBURETOR WAS ORIGINALLY PURCHASED.**

Final warranty determination will be the decision of Holley® Performance products.

Some states do not allow the exclusion or limitation of incidental or consequential damages, or limitations on how long an implied warranty lasts, so the above limitations or exclusions may not apply to you.

This warranty gives you specific legal rights, and you may also have other rights that vary from state to state. This warranty shall apply only within the boundaries of the continental United States.

**Holley® Performance Products, Inc.
1801 Russellville Road
Bowling Green, KY 42101-3542**

**Technical Service: 1-866-464-6553
Phone: 1-270-781-9741**

© 2016 Holley Performance Products, Inc. All rights reserved.

199R11075

Date: 6-13-16