



GM LS/LT Engine Mount Components

71221016HKR, 71221017HKR, 71221018HKR, 71221019HKR, 71223015HKR, & 71223016HKR Installation Instructions



71221016HKR



71221019HKR



71223015HKR



71223016HKR

Thank you for choosing to use Holley™ LS/LT engine mount components as part of your performance vehicle project. These mounts may be used as direct replacement parts on any 1998-02 V8 equipped GM F-body vehicle, or to perform an LT engine swap in a 1998-02 V8 equipped GM F-body vehicle using the factory frame stands. Additionally, they may be used to mount an LS or LT engine into a GM 1983-93 F-body or 1964-72 A-body vehicle using specific Hooker LS engine swap brackets developed for those applications. Please read these instructions thoroughly before attempting installation.

PRE-INSTALLATION CONSIDERATIONS:

These components were designed in conjunction with one another to eliminate the rivet-drilling operation typically required to install polyurethane inserts in 1998-2002 GM F-body vehicles.

Holley LS and LT clamshell housings are both stamped from thicker gauge steel than is typically used to manufacture clamshell housings of stock replacement LS engine mounts, which means they provide a stronger mounting foundation for high horsepower applications.

While easy to install, careful attention should be paid to the installation steps within this document to ensure the insert is not installed into the clamshell upside-down or backwards, which would cause in-car installation issues.

COMPATIBILITY INFORMATION:

Although Holley clamshell housings (LS and LT versions) were CAD designed specifically for use with Holley polyurethane inserts, they will physically accept GM 1998-02 F-body LS polyurethane inserts from Energy Suspension™ and Prothane™ also.

BEFORE BEGINNING...

Check that the hardware package includes the following:

71221016HKR- (1) **black** LS/LT polyurethane insert

71221017HKR- (1) **red** LS/LT polyurethane insert

71221018HKR- (1) **LS** engine mount clamshell (upper and lower halves), (4) 5/16 bolts, (4) 5/16 washers and (4) 5/16 lock nuts

71221019HKR- (1) **LT** engine mount clamshell (upper and lower halves), (4) 5/16 bolts, (4) 5/16 washers and (4) 5/16 lock nuts

71223015HKR- (2) M12 x 150mm flanged head, Grade 10.9, LS/LT engine mount/bracket couple-bolts, (2) M12 flanged nuts

71223016HKR- (4) 5/16 bolts, (4) 5/16 washers and (4) 5/16 lock nuts (this is a replacement hardware kit for the fasteners included with the 71221018HKR and 71221019HKR engine mount clamshell kits).

INSTALLATION:

1. Install the insert between the upper and lower clamshell halves while ensuring that the following conditions of orientation are met:
 - A. The metal tangs protruding from the ends of the insert are offset towards the top of the clamshell halves (the side with a straight edge compared to the slight "V" shaped edge of the bottom side).
 - B. The longer end of the insert protrudes from the right side of the clamshell housing. This is the case with both mounts to be installed on an engine, which means when installed on the engine, the longer end of the inserts will point towards the front of the car on the passenger's side of the engine, and towards the rear of the car on the driver's side of the engine.
2. With the above conditions met, fasten the upper and lower clamshell halves together using the 5/16" hardware included with each clamshell housing. Install the fasteners in the orientation shown in **Figure 1** on the next page (LT clamshell shown, LS clamshell similar).

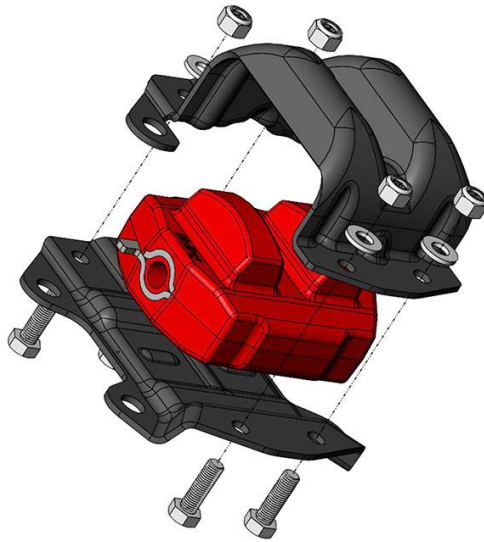

Figure 1

3. Ensure the two large holes in the bottom of the upper and lower halves are aligned to allow unobstructed insertion of M10 bolts through each of them and then torque the 5/16 bolt/washer/nut assemblies to approximately 29 ft./lbs.
4. Attach the clamshell/insert assemblies to the intended engine with user-supplied M10 fasteners with the straight edge of the clamshells facing up as depicted in **Figure 2**.

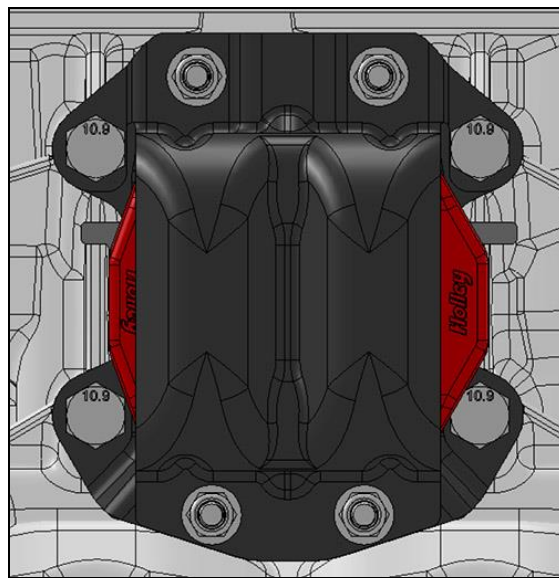

Figure 2

5. Lower the engine onto the vehicle engine mounting brackets and couple the engine mounts to the brackets using the M12 bolts and nuts included in the 71223015HKR hardware kit, or with similar fasteners. Tighten bolt/nut assemblies

LIMITATION OF LIABILITY – DISCLAIMER:

HOLLEY/HOOKER™ makes no warranties of merchantability, of fitness for particular purpose, or that its products are approved for general use, or that its products comply with laws, regulations, or ordinances in the state where they may be sold to the ultimate purchaser, the consumer.

Unless expressly stated to the contrary in the catalog, instruction sheet; or price list, the entire risk as to the conformity of any company product in any such state and as to repair should the product prove to be defective or non-conforming, is on the retail purchaser, the buyer, the ultimate consumer, of such product and it is not upon the seller, distributor, or manufacturer.

In this connection, the retail purchaser, the buyer, the ultimate consumer assumes the burden of the entire cost of any and all necessary service, alterations, or repair.

© 2017 Hooker Headers, Inc. All rights reserved

199R11359

Date: 6-30-17