

INSTRUCTION SHEET

OFF VEHICLE CARBURETOR SERVICE

HOLLEY MODEL — 2210, 2245

50-404-10

GENERAL EXPLODED VIEW

THE GENERAL DESIGN AND PARTS SHOWN WILL VARY TO INDIVIDUAL UNITS COVERED ON THIS INSTRUCTION SHEET

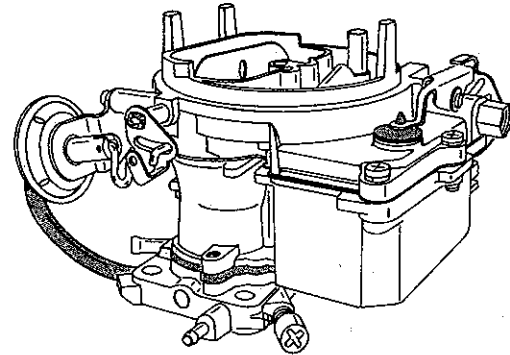
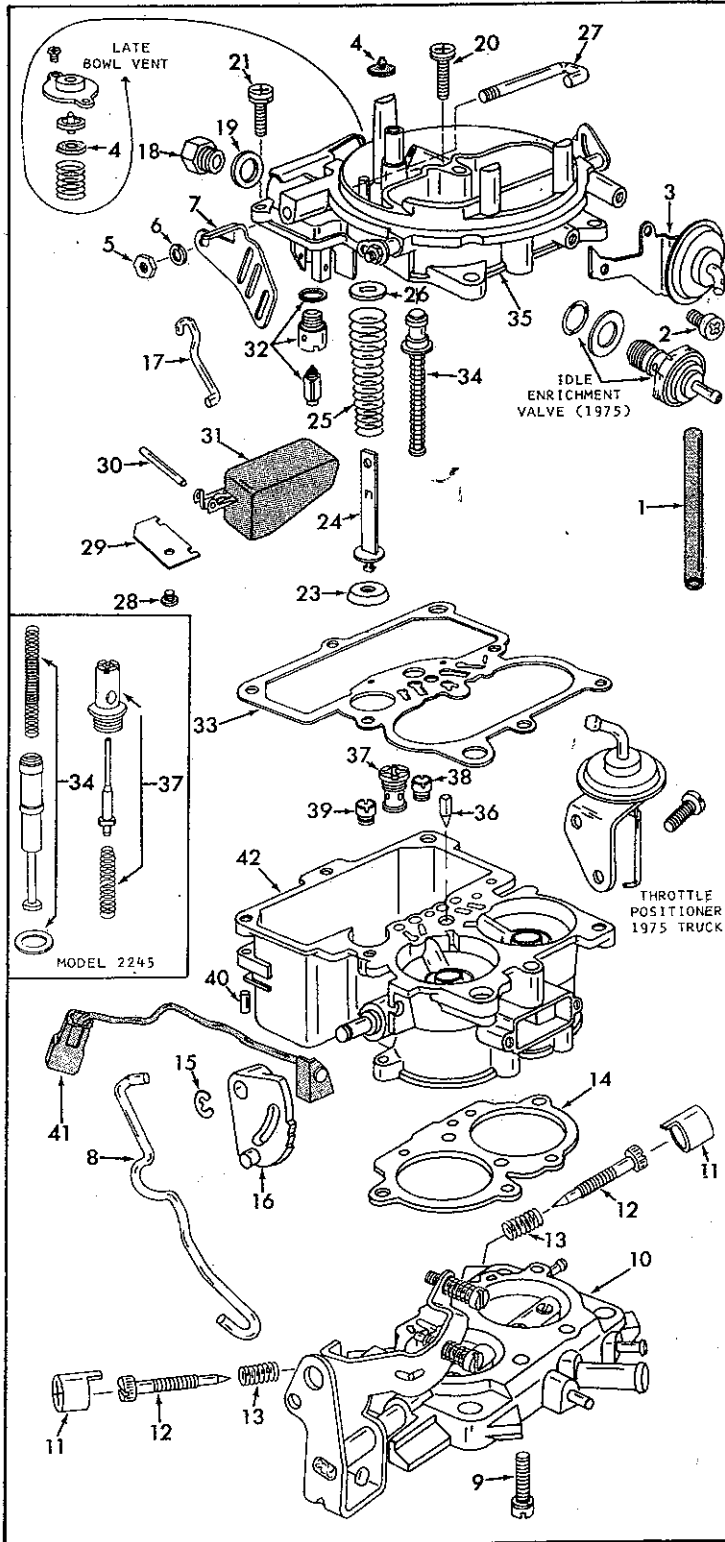

DISASSEMBLY

USE EXPLODED VIEW AS A GUIDE. THE NUMERICAL SEQUENCE MAY GENERALLY BE FOLLOWED TO DISASSEMBLE UNIT FAR ENOUGH TO PERMIT CLEANING AND INSPECTION. CAUTION: MAIN WELL TUBES ARE NOT REMOVABLE TAKE EXTREME CARE SO AS NOT TO BEND OR DAMAGE TUBES.

NOTE: REMOVE STAKING FROM BOWL COVER FOR EASY REMOVAL OF POWER PISTON ASSEMBLY (34). USE SLOTTED SCREW DRIVER TO REMOVE POWER VALVE ASSEMBLY (37). DO NOT REMOVE IDLE LIMITER CAPS (11) UNLESS NEW ONES ARE AVAILABLE.

NOMENCLATURE

| REF. NO. | REF. NO. |
|--|---|
| 1. HOSE-CHOKE VACUUM | 21. SCREW & LOCKWASHER (7)-BOWL COVER |
| 2. SCREW (2)-CHOKE DIAPHRAGM BRACKET | 22. BOWL COVER ASSEMBLY |
| 3. CHOKE DIAPHRAGM AND LINK ASSY. | 23. CUP-PUMP |
| 4. VALVE-BOWL VENT | 24. PUMP STEM |
| 5. NUT-PUMP LEVER | 25. SPRING-PUMP DRIVE |
| 6. LOCKWASHER-PUMP LEVER | 26. WASHER-PUMP SPRING |
| 7. LEVER-PUMP | 27. PUMP LEVER SHAFT |
| 8. LINK-PUMP | 28. SCREW & LOCKWASHER-FUEL BOWL BAFFLE |
| 9. SCREW & LOCKWASHER (5)-THROTTLE BODY | 29. FUEL BOWL BAFFLE |
| 10. THROTTLE BODY ASSEMBLY | 30. PIN-FLOAT HINGE |
| 11. CAP-IDLE LIMITER | 31. FLOAT & LEVER ASSEMBLY |
| 12. NEEDLE-IDLE ADJUSTING | 32. NEEDLE, SEAT & GASKET ASSY. |
| 13. SPRING-IDLE ADJ. NEEDLE | 33. GASKET-BOWL COVER |
| 14. GASKET-THROTTLE BODY | 34. PISTON ASSY.-POWER VALVE |
| 15. RETAINER-FAST IDLE CAM | 35. BOWL COVER |
| 16. CAM-FAST IDLE | 36. NEEDLE-PUMP DISCHARGE |
| 17. LINK-FAST IDLE CAM | 37. VALVE ASSY.-POWER |
| 18. FITTING-FUEL INLET | 38. JET-(63)-MAIN (CHOKE-SIDE) |
| 19. GASKET-FUEL INLET FITTING | 39. JET-(65)-MAIN (PUMP-SIDE) |
| 20. SCREW & LOCKWASHER (1)-BOWL COVER (LONG) | 40. PIN-WIRE RETAINER |
| | 41. STOP & CABLE ASSEMBLY |
| | 42. BOWL-FUEL |

CLEANING

CLEANING MUST BE DONE WITH CARBURETOR DISASSEMBLED. SOAK PARTS LONG ENOUGH TO SOFTEN AND REMOVE ALL FOREIGN MATERIAL. USE (1) A CARBURETOR CLEANING SOLVENT, (2) LACQUER THINNER OR (3) DENATURATED ALCOHOL. MAKE CERTAIN THE THROTTLE BODY IS FREE OF ALL HARD CARBON DEPOSITS. WASH OFF IN SUITABLE SOLVENT. BLOW OUT ALL PASSAGES IN CASTINGS WITH COMPRESSED AIR AND CHECK CAREFULLY TO INSURE THOROUGH CLEANING OF OBSCURE AREAS.

CAUTION: DO NOT SOAK PARTS CONTAINING RUBBER AND CERTAIN PLASTIC MATERIAL SUCH AS: (1)-(3)-(4)-(31)-(41)

REASSEMBLY

REASSEMBLE IN THE REVERSE ORDER OF DISASSEMBLY. NOTE SPECIAL INSTRUCTIONS AND FOLLOW NUMERICAL OUTLINE IN MAKING ADJUSTMENTS

SPECIAL INSTRUCTIONS

MAIN JET INSTALLATION (EARLY MODELS) - INSTALL LEAN JET (38) ON CHOKE SIDE OF BOWL AND RICHER JET (39) ON PUMP SIDE.

POWER PISTON INSTALLATION (34) - LIGHTLY STAKE CASTING AROUND WASHER.

BOWL COVER SCREWS (20)(21) - START AT CENTER SCREW AND TIGHTEN TO 25 INCH LBS. FROM CENTER OUT.

PUMP LINK (8) - INSTALL IN PROPER SLOT OF PUMP LEVER (7), CHECK FIG. 3

IDLE LIMITER CAPS (11) - IF CAPS WERE REMOVED FOLLOW CAR MANUFACTURERS PROCEDURE TO ADJUST IDLE AND INSTALL NEW CAPS.

ADJUSTMENTS

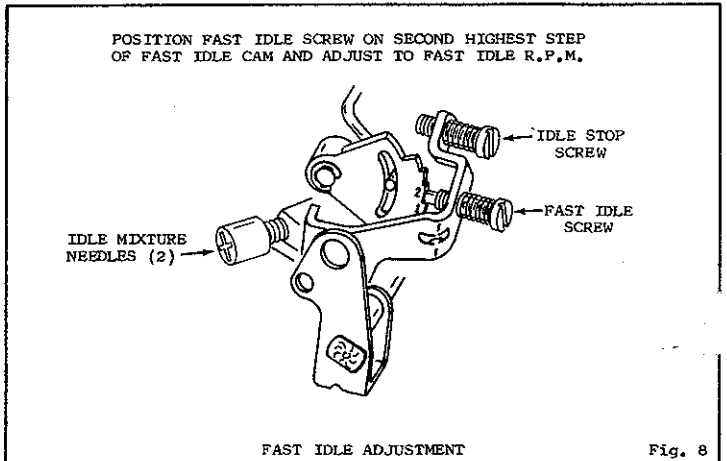
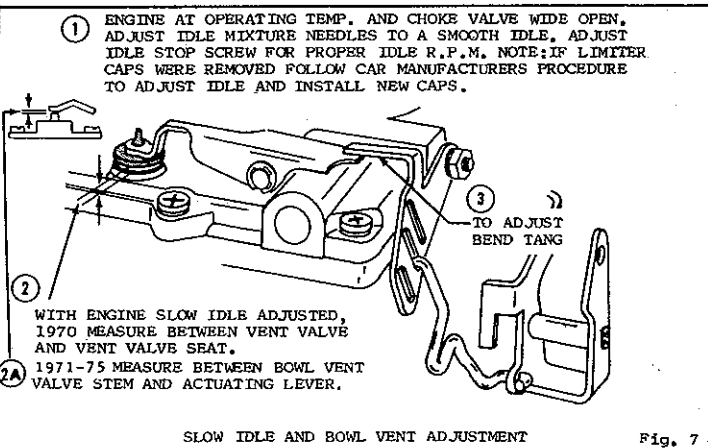
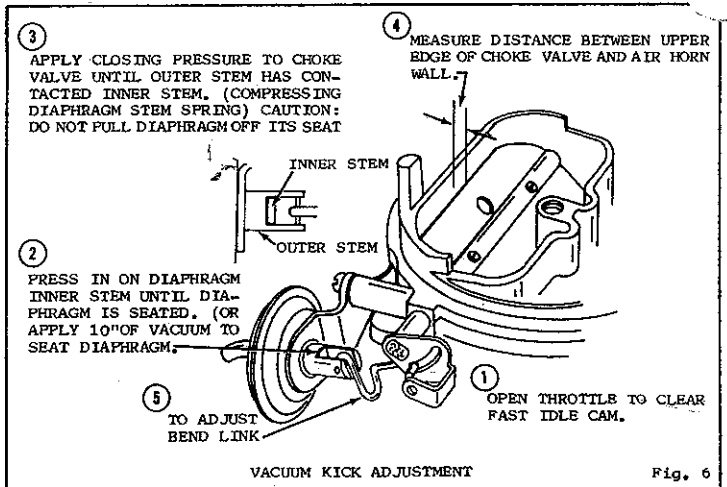
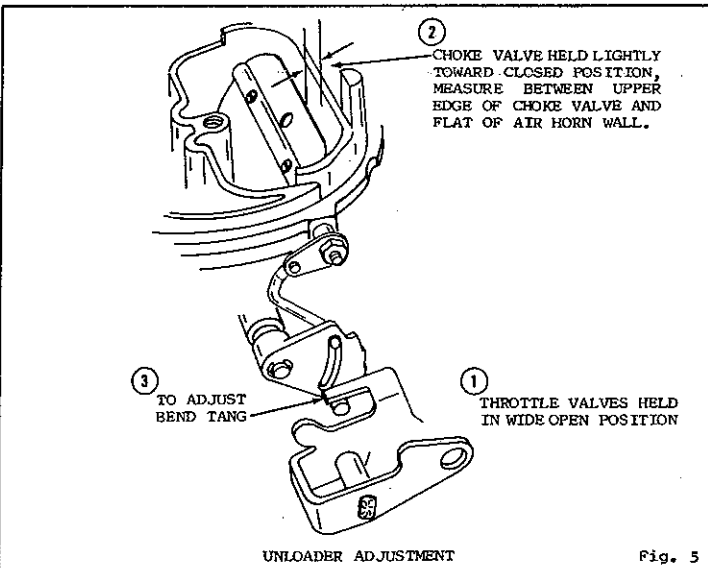
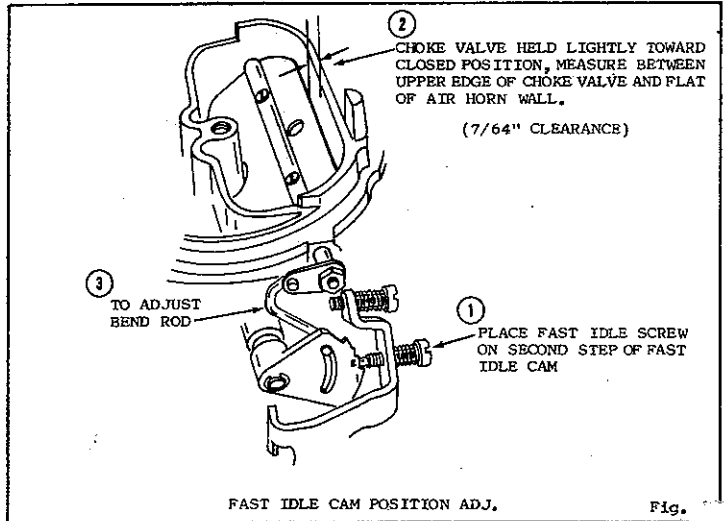
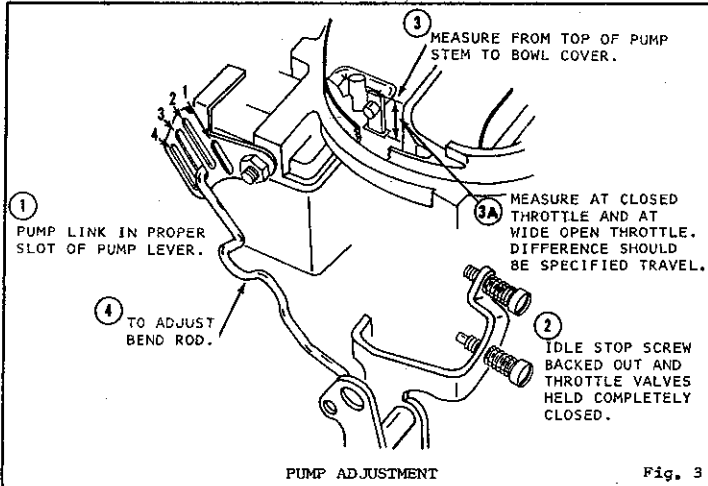
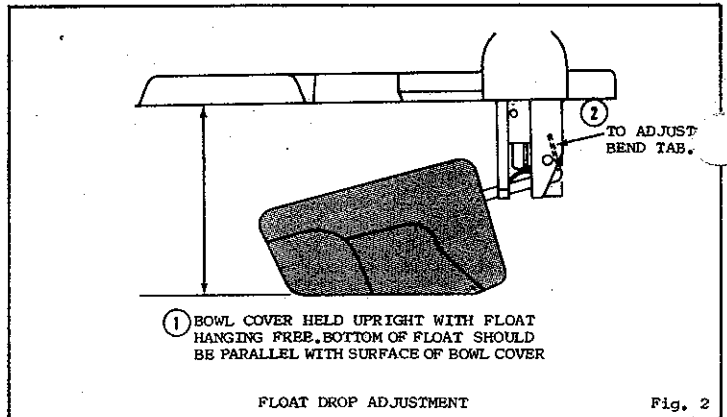
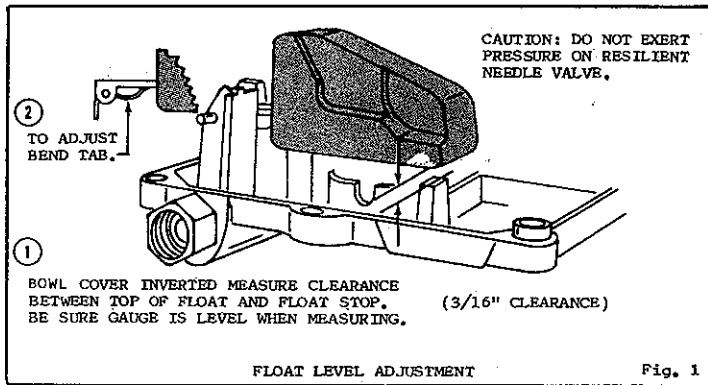

ADJUSTMENTS

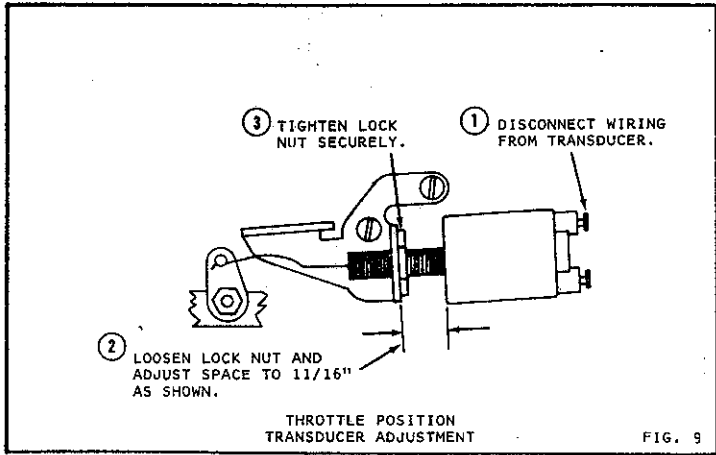

ADJUSTMENT DATA TABLE

| YEAR | APPLICATION | FLOAT LEVEL (DRY) | PUMP ADJUSTMENT | | UNLOADER | VACUUM KICK | SLOW IDLE R.P.M. NOTE-1 | BOWL VENT | FAST IDLE R.P.M. | DASHPOT SETTING ON CAR |
|---------|----------------------------|-------------------|-----------------|-------------|----------|-------------|-------------------------|-----------|------------------|------------------------|
| | | | SLOT | SETTING | | | | | | |
| 1970 | CHRYSLER PRODUCTS | | | | | | | | | |
| | 360" ENG. | 3/16" | 3 | 9/16" (3) | 11/64" | 9/64" | A/T 650 | 5/64" | 1700 | ---- |
| 1971 | 400" ENG. | 3/16" | 1 | 19/32" (3) | 11/64" | 9/64" | S/T 750 | 5/64" | 1700 | ---- |
| | 360" ENG. | 3/16" | 3 | 9/16" (3) | 11/64" | 9/64" | A/T 700 | 1/64" | 1800 | ---- |
| 1972 | 400" ENG. | 3/16" | 1 | 19/32" (3) | 11/64" | 9/64" | S/T 750 | 1/64" | 1800 | ---- |
| | 360" ENG. | 3/16" | 3 | 9/16" (3) | 11/64" | 9/64" | A/T 700 | 1/64" | 1900 | ---- |
| 1973 | 400" ENG. | 3/16" | 1 | 19/32" (3) | 11/64" | 7/64" | S/T 750 | 1/64" | 2000 | Calif. |
| | 360" ENG. | 3/16" | 3 | 1/4" (3A) | 11/64" | 5/32" | 750 | 1/64" | 1900 | ---- |
| 1974 | 400" ENG. | 3/16" | 3 | 1/4" (3A) | 11/64" | 5/32" | 700 | 1/64" | 1800 | ---- |
| | 360" ENG. | 3/16" | 1 | 1/4" (3A) | 11/64" | 5/32" | 750 | 1/64" | 1800 | ---- |
| 1975 | 400" ENG. | 3/16" | 1 | 1/4" (3A) | 11/64" | 5/32" | 700 | 1/64" | 1600 | ---- |
| | 360" ENG. | 3/16" | 1 | 1/4" (3A) | 11/64" | 5/32" | 750 | 1/64" | 1600 | ---- |
| 1975-76 | 400" ENG. | 3/16" | 1 | 1/4" (3A) | 11/64" | 5/32" | 700 | 1/64" | 1600 | ---- |
| | 360" ENG. TRUCK | 3/16" | 1 | 5/16" (3A) | 11/64" | 5/32" | 750 | ---- | 1800 | ---- |
| 1976 | 400" ENG. TRUCK | 3/16" | 1 | 5/16" (3A) | 11/64" | 5/32" | 700 | ---- | 1600 | ---- |
| | 360" ENG. | 3/16" | 1 | 5/16" (3A) | 11/64" | 5/32" | 700 | .025 | 1600 | ---- |
| 1977 | 400" ENG. | 3/16" | 1 | 5/16" (3A) | 11/64" | 5/32" | 700 | .025 | 1600 | ---- |
| | 360" ENG. | 3/16" | 1 | 5/16" (3A) | 11/64" | 7/64" | 700 | .025 | 1700 | ---- |
| 1977-80 | 360" ENG. TRUCK M/T | 3/16" | 2 | 21/64" (3A) | 11/64" | 5/32" | 750 | ---- | 1700 | ---- |
| | 360" ENG. TRUCK A/T | 3/16" | 1 | 5/16" (3A) | 11/64" | 5/32" | 750 | ---- | 1600 | ---- |
| 1978 | 400" ENG. TRUCK A/T | 3/16" | 1 | 5/16" (3A) | 11/64" | 5/32" | 700 | ---- | 1400 | ---- |
| | 360" ENG. | 3/16" | 1 | 17/64" (3A) | 11/64" | 7/64" | 750 | .025 | 1600 | ---- |
| 1978-79 | 360" ENG. TRUCK AII/T | 3/16" | 2 | 5/16" (3A) | 11/64" | 7/32" | 750 | ---- | 1600 | ---- |
| | 360" ENG. Carb. No. R8135A | 3/16" | 1 | 5/16" (3A) | 11/64" | 5/32" | 750 | ---- | 1800 | ---- |
| 1978-79 | 360" ENG. Carb. No. R7871A | 3/16" | 2 | 5/16" (3A) | 11/64" | 1/8" | 750 | ---- | 1600 | ---- |
| | 400" ENG. TRUCK AII/T | 3/16" | 1 | 5/16" (3A) | 11/64" | 5/32" | 700 | ---- | 1600 | ---- |
| 1979 | 360" ENG. TRUCK | 3/16" | 1 | 19/64" (3A) | 11/64" | 7/64" | 750 | .025 | 1600 | ---- |
| | 360" ENG. CARB. NO. R9816A | 3/16" | 1 | 17/64" (3A) | 11/64" | 5/32" | 750 | ---- | 1700 | ---- |
| 1973 | I.H.C. PRODUCTS | | | | | | | | | |
| | Carb. No. R6776A Calif. | 3/16" | 1 | 45/64" (3) | 7/32" | 9/64" | 745/760 | .020 | 2200 | 5/64" |
| 1973-74 | Carb. No. R6674A,1A,2A | 3/16" | 1 | 45/64" (3) | 7/32" | 11/64" | 745 | .020 | 2200 | 5/64" |
| | 400" ENG. | 3/16" | 1 | 45/64" (3) | 7/32" | 9/64" | 745/760 | .020 | 2200 | 5/64" |
| 1973-75 | Carb. No. R6443A,1A | 3/16" | 2 | 45/64" (3) | 7/32" | 9/64" | 745/760 | .020 | 2200 | 5/64" |
| | 304"/345" ENG. | 3/16" | 2 | 45/64" (3) | 7/32" | 9/64" | 745/760 | .020 | 2200 | 5/64" |
| 1973-76 | Carb. No. R6620A,1A,2A | 3/16" | 1 | 45/64" (3) | 7/32" | 7/64" | 740 | ---- | 2200 | ---- |
| | 304"/345" ENG. | 3/16" | 1 | 45/64" (3) | 7/32" | 7/64" | 740 | ---- | 2200 | ---- |
| 1974 | Carb. No. R6828A | 3/16" | 1 | 45/64" (3) | 7/32" | 9/64" | 575 | .020 | 2200 | ---- |
| | 304"/345" ENG. | 3/16" | 1 | 45/64" (3) | 7/32" | 9/64" | 575 | .020 | 2200 | ---- |
| 1974 | Carb. No. R7037A | 3/16" | 1 | 45/64" (3) | 7/32" | 11/64" | E/D | ---- | E/D | ---- |
| | 400" H/D ENG. | 3/16" | 1 | 45/64" (3) | 7/32" | 11/64" | E/D | ---- | E/D | ---- |
| 1974-75 | Carb. No. R7309A | 3/16" | 1 | 45/64" (3) | 7/32" | 9/64" | E/D | ---- | E/D | ---- |
| | 304"/345" ENG. | 3/16" | 1 | 45/64" (3) | 7/32" | 9/64" | E/D | ---- | E/D | ---- |
| 1975-76 | Carb. No. R7133A | 3/16" | 1 | 45/64" (3) | 7/32" | 5/32" | E/D | ---- | 2000 | ---- |
| | 345" ENG. Calif. | 3/16" | 1 | 45/64" (3) | 7/32" | 5/32" | E/D | ---- | 2000 | ---- |
| 1975-76 | Carb. No. R7214A, R7217A | 3/16" | 1 | 45/64" (3) | 7/32" | 9/64" | E/D | ---- | E/D | ---- |
| | MV 404" ENG. | 3/16" | 1 | 45/64" (3) | 7/32" | 9/64" | E/D | ---- | E/D | ---- |
| 1977-79 | Carb. No. R7940A, R8241A | 3/16" | 2 | ---- | 7/32" | 1/16" | E/D | ---- | E/D | ---- |
| | 345" ENG. | 3/16" | 2 | ---- | 7/32" | 1/16" | E/D | ---- | E/D | ---- |
| 1977 | Carb. No. R7657A | 3/16" | 2 | ---- | 7/32" | 9/64" | E/D | ---- | E/D | ---- |
| | 404" ENG. | 3/16" | 2 | ---- | 7/32" | 9/64" | E/D | ---- | E/D | ---- |
| 1978 | Carb. No. R8244A | 3/16" | 1 | ---- | 7/32" | 9/64" | E/D | ---- | E/D | ---- |
| | 404" ENG. | 3/16" | 1 | ---- | 7/32" | 9/64" | E/D | ---- | E/D | ---- |
| 1979 | Carb. No. R7773A | 3/16" | 2 | 45/64" (3) | 7/32" | 1/8" | E/D | ---- | E/D | ---- |
| | 304" ENG. | 3/16" | 2 | 45/64" (3) | 7/32" | 1/8" | E/D | ---- | E/D | ---- |
| 1980 | Carb. No. R8790A | 3/16" | 2 | 45/64" (3) | 7/32" | 1/8" | E/D | ---- | E/D | ---- |
| | 304" ENG. | 13/64" | 2 | 45/64" (3) | 7/32" | 1/8" | E/D | ---- | E/D | ---- |

E/D=ENGINE DECAL

REV. 3--83.

NOTE-1CHECK ENGINE DECAL FOR SPECIAL IDLE INFORMATION.

**ADJUSTMENT DATA TABLE
HOLLEY REPLACEMENT CARBS**

| YEAR | ENGINE | CARB. NO. | FLOAT LEVEL DRY | PUMP SLOT | UNLOADER | VACUUM KICK | BOWL VENT |
|----------------------------------|---------|--------------------|-----------------|-----------|----------|-------------|-----------|
| BUICK | 1971-72 | 350" | R-7668 | 3/16" | NO. 2 | 11/64" | 5/64" |
| | 1973-74 | 350" | R-7669 | 3/16" | NO. 1 | 11/64" | 5/64" |
| CHEVROLET | 1969-70 | 327", 350" | R-7664 | 3/16" | NO. 2 | 11/64" | 3/32" |
| | 1971-72 | 396", 400" | R-7665 | 3/16" | NO. 2 | 11/64" | 3/32" |
| | | 350", 400" | R-7666 | 3/16" | NO. 1 | 11/64" | 3/32" |
| | 1973-74 | 350", 400" | R-7666 | 3/16" | NO. 1 | 11/64" | 3/32" |
| CHEVROLET TRUCK | 1974 | 350" | R-7666 | 3/16" | NO. 1 | 11/64" | 3/32" |
| CHRYSLER PROD. DODGE/PLYMOUTH | 1963-74 | 360", 383" 400" | R-7641 | 3/16" | NO. 2 | 11/64" | 7/64" |
| | | | R-7642 | 3/16" | NO. 2 | 11/64" | 7/64" |
| | | | R-7643 | 3/16" | NO. 2 | 11/64" | 13/64" |
| | | | R-7644 | 3/16" | NO. 2 | 11/64" | 13/64" |
| | | | R-7686 | 3/16" | NO. 2 | 11/64" | 7/32" |
| GMC TRUCK | 1974 | | R-8702 | | | | |
| PONTIAC | 1968-72 | 350", 400" | R-7667 | 3/16" | NO. 2 | 11/64" | 1/16" |