



**P/N 5204HKR (painted) & 5204-1HKR (ceramic coated)
SUPER COMPETITION FULL LENGTH CAR HEADERS
1970-72 Dodge Dart, Demon, Swinger, Plymouth Duster, & Valiant
1964-69 Plymouth Barracuda
(A&F Bodies) 318-360**

NOTE: WILL NOT FIT MOTORS EQUIPPED WITH AIR INJECTION PUMP WITHOUT MODIFICATION.

NOTE: WILL NOT FIT 1970 – 72 DUSTERS WITH POWER STEERING.

NOTE: Hooker headers for MOPAR 318-360 engines will bolt on the popular aftermarket B-A heads. However, because the exhaust port centerline on these heads is 5/8" higher and 3/8" out from the engine centerline compared to stock heads, some header modifications will be required for installation. Spark plug locations require cutting the header flanges for clearance.

Thank you for making HOOKER HEADERS your choice in a high-performance exhaust system. Extensive dyno/track testing has enabled HOOKER to offer the most advanced design in exhaust systems. The installation, while not complex, will take a certain amount of time. However, the additional horsepower and improved performance will more than justify your efforts. Proper installation and maintenance will ensure long life and maximum performance from your hooker exhaust system.

WARNING! Breaking in an engine with ceramic-coated headers WILL result in damage to the coating and will VOID all warranties. Ceramic-coated headers require several heat cycles to fully cure before they will withstand extreme heat. HOOKER recommends using a cast-iron exhaust manifold or an old header to break in new engines to avoid coating damage.

BEFORE STARTING

Your vehicle must be raised a minimum of 36 inches. A floor hoist is ideal. If no hoist is available, we strongly urge the use of axle stands as a safety measure. **CAUTION! YOUR CAR SHOULD NOT BE SUPPORTED ON A BUMPER JACK.**

INSTALLATION PROCEDURE – PLEASE READ CAREFULLY

LEFT SIDE:

1. Disconnect the battery cable to prevent damage to the electrical system.
2. Unbolt the headpipe from the stock exhaust manifold and push aside.
3. Remove the center drag link from the Pittman arm and idler arm. Push the idler arm to the outside of the car.
4. Remove the oil filter and housing from the block.
5. Remove the bellhousing brace (if equipped).
6. Drain the radiator (coolant may be reused, if drained into a clean container). Remove the studs from the head.
7. Remove the slip tube (L-1 tube) from the main body of the header.
8. Starting from below, work the main body of the header up through the chassis.
9. Place the gasket into position and start two bolts to hold the header. Install the slip tube (from above), the oil filter base, and oil filter. Start all bolts. We recommend the use of a sealant on studs/bolts to prevent coolant leakage.
10. Tighten all header bolts evenly. Replace spark plugs.

RIGHT SIDE:

1. Remove the transmission locking device. Cut and weld the bracket that bolts to the frame (**Figure A**).
2. Remove the spark plugs, exhaust manifold, starter, and center motor mount bolt.
3. Raise the engine about one inch (using a flat board between the oil pan and the jack).
4. Remove the slip tube (R-1 tube) from the main body of the header.
5. Starting from below, work the header up through the chassis into position. **DO NOT START ANY BOLTS.** Now, lower the engine and replace the center motor mount bolts.
6. With the header loose, reinstall the starter mount.
7. Place the gasket into position and start all bolts.
8. Install the slip tube (R-1 tube) and start all bolts.
9. Tighten all header bolts evenly. Replace spark plugs.
10. Replace the center drag link to the Pittman arm and idler arm.
11. Replace the transmission locking device, installing the brackets upside down, so the cross shaft is over the tip of the collector.

- NOTE:** Check the linkage on the steering column. Some models may require modification of linkage for adequate header clearance.
12. To connect the collectors to the headpipes, purchase Hooker reducer kit 11030HKR. Bolt reducers (with gasket) to the collectors, line up the headpipes, cut to the correct length, and weld to the reducers.
 13. Refill the radiator and connect the battery. Replace the spark plugs.
 14. Start the engine and check for leaks. Make sure all brake lines, fuel lines, and electrical wires have sufficient clearance.
 15. When finished, give your vehicle a test drive, checking carefully for any new noises. After several days of driving, retighten all bolts.

Any questions? Please contact Technical Service: 1-866-464-6553 or 270-781-9741. For online help, please refer to the website: www.holley.com.

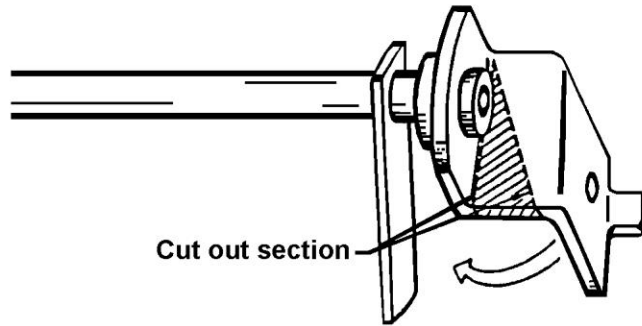

Figure A

LIMITATION OF LIABILITY – DISCLAIMER:

The regulation of emissions production, noise levels, and safety standards is undertaken by the federal government, each of the fifty state legislatures, and by many local municipalities, towns, and counties.

HOKKER makes no warranties of merchantability, of fitness for particular purpose, or that its products are approved for general use, or that its products are approved for general use, or that its products comply with laws, regulations, or ordinances in the state where they may be sold to the ultimate purchaser, the consumer.

Unless expressly stated to the contrary in the catalog, instruction sheet; or price list, the entire risk as to the conformity of any company product in any such state and as to repair should the product prove to be defective or non-conforming, is on the retail purchaser, the buyer, the ultimate consumer, of such product and it is not upon the seller, distributor, or manufacturer.

In this connection, the retail purchaser, the buyer, the ultimate consumer assumes the burden of the entire cost of any and all necessary service, alterations, or repair.

THE FOREGOING STATEMENT LIMITS THE LIABILITY OF THE MANUFACTURER.

California vehicle code, sections 27156 and 38391, prohibits the advertising, offering for sale, or installation of any device, which modifies a vehicle's emission control system, unless exempted, unless otherwise noted. HOKKER™ Headers that have not received an Executive Order (E.O.) exemption from these code sections are not legal for sale or use in California on vehicles originally equipped with catalytic converters, except for racing vehicles, which may never be driven upon a highway. Check with your local authorities to determine if these headers are legal for use in your particular area.

5204HKR

Revision Date: 12-30-15