



**5901HKR (black painted), 5901-1HKR (silver ceramic),  
5901-3HKR (Darkside black ceramic), & 5901-4HKR (Titanium)  
COMPETITION DODGE/PLYMOUTH HEADERS  
1967-82 All B & E (A & F Bodies) 273-360**

**NOTE:** WILL NOT FIT MOTORS EQUIPPED WITH AIR INJECTION PUMP WITHOUT MODIFICATION.

**NOTE:** Hooker headers for MOPAR 318-360 engines will bolt on the popular aftermarket B-A heads. However, because the exhaust port centerline on these heads is 5/8" higher and 3/8" out from the engine centerline compared to stock heads, some header modifications will be required for installation. Spark plug locations require cutting the header flanges for clearance.

Thank you for making HOOKER HEADERS your choice in a high-performance exhaust system. Extensive dyno/track testing has enabled HOOKER to offer the most advanced design in exhaust systems. The installation, while not complex, will take a certain amount of time. However, the additional horsepower and improved performance will more than justify your efforts. Proper installation and maintenance will ensure long life and maximum performance from your hooker exhaust system.

**WARNING! Breaking in an engine with ceramic-coated headers WILL result in damage to the coating and will VOID all warranties. Ceramic-coated headers require several heat cycles to fully cure before they will withstand extreme heat. HOOKER recommends using a cast-iron exhaust manifold or an old header to break in new engines to avoid coating damage.**

**BEFORE STARTING**

Your vehicle must be raised a minimum of 36 inches. A floor hoist is ideal. If no hoist is available, we strongly urge the use of axle stands as a safety measure.

**CAUTION! YOUR CAR SHOULD NOT BE SUPPORTED ON A BUMPER JACK.**

**INSTALLATION PROCEDURE – PLEASE READ CAREFULLY**

**LEFT SIDE:**

1. Disconnect the battery cable to prevent damage to the electrical systems.
2. Remove the stock headpipe and exhaust manifold. Remove the spark plugs and (if stick) clutch linkage.
3. Drain the radiator (coolant may be reused, if drained into a clean container). Remove the front and rear studs from the head.

**NOTE:** Engines with smog heads (but without smog pump) must have the smog air holes plugged. Purchase (8) 1/4"-20 x 1/4" long Allen head set screws. Thread the holes with a 1/4"-20 tap (use a small wrench to turn the tap). Make sure the screw heads are flush with or below the exhaust port service. **See Figure A.**

4. Remove the left side tie rod from the drag link. Remove the drag link from the Pittman arm. Disconnect and remove the starter. Remove the shift linkage and kickdown linkage.
5. Starting from below, work the header up into position. Hang the header on the front stud.

**NOTE:** Some vehicles will require raising the engine approximately 3" to install the headers. Remove the center bolt from the motor mount. Also, on some models, it may be necessary to remove the bolts holding the steering box so that it may be moved aside. Use a board between the oil pan and jack. Work the header into position, lower the motor, and replace the motor mount bolts. Replace the bolts for the steering box and tighten.

6. With the header loose, replace the starter. Reconnect the drag link to the Pittman arm and the tie rod to the drag link.
7. Remove the header from the front stud, positioning the flange gasket. Start all header bolts (most restricted first).

**NOTE:** We recommend using a sealant on the threads of the bolt used to replace the rear stud (to prevent leakage of coolant).

8. Tighten all header bolts evenly. Replace spark plugs.
9. If stick, replace the clutch linkage. If automatic (with shift column). Modify linkage according to **Figures B & C** and reinstall. Replace the kickdown linkage.
10. Check the power steering hoses and (if equipped) automatic transmission cooler lines for adequate header clearance. Reroute, as necessary.

**RIGHT SIDE:**

1. Remove the stock exhaust manifold, spark plugs, and oil filter.
2. Remove the studs from the head and brace from the engine to the bellhousing (if so equipped).

**NOTE:** Engines with smog heads (but without smog pump) must have the smog air holes plugged. Purchase (8) 1/4"-20 x 1/4" long Allen head set screws. Thread the holes with a 1/4"-20 tap (use a small wrench to turn the tap). Make sure the screw heads are flush with or below the exhaust port service. **See Figure A.**

3. Remove the center bolt from the motor mount.
4. Raise the engine several inches (using a flat board between the oil pan and the jack).
5. Starting from below, work the header up through the chassis into position.
6. Position the gasket and start all bolts.

**NOTE:** We recommend using a sealant on the threads of the bolt used to replace the rear stud (to prevent leakage of coolant).

7. Lower the engine and replace the center bolt in the motor mount.
8. Tighten all bolts evenly.
9. Replace the oil filter. Reinstall all the steering linkage removed (double check it).
10. Check the clearance between pipe (R-2) and the idler arm. It must be 1/4" or more. If not, replace the motor mounts.
11. Check that all gas lines, brake lines, and electrical wires have sufficient clearance. Reroute, as necessary.

12. Purchase Hooker Reducer Kit, P/N 11030HKR, to connect the headers to your stock exhaust system.

**NOTE:** Finish the performance job your headers started by adding a Hooker Competition Universal Dual Exhaust system. Large 2 1/4" diameter tubing is mandrel bent, not press bent. Mandrel bending maintains a consistent inside diameter for maximum flow. Press bending will crush the pipe, easily reducing volume by more than 10%. Our universal dual exhaust system comes complete with 2 Hooker Competition Turbo mufflers. (No reducer is required when using our dual exhaust system.) Purchase P/N 16500HKR.

13. Refill the radiator and connect the battery. Replace the spark plugs.

14. Start the engine and check for leaks.

15. When finished, give your vehicle a test drive, checking carefully for any new noises. After several days of driving, retighten all bolts.

Any questions? Please contact Technical Service: 1-866-464-6553 or 270-781-9741. For online help, please refer to the website: [www.holley.com](http://www.holley.com).

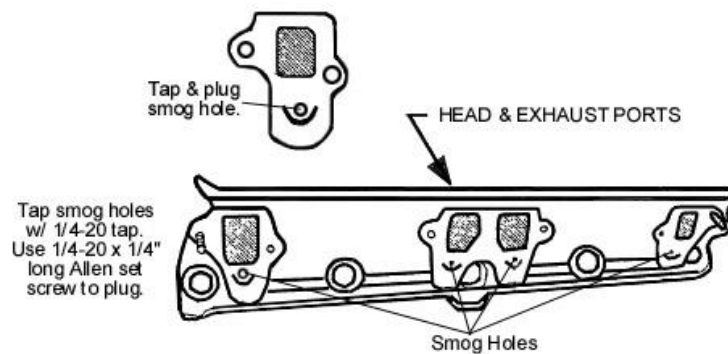

Figure A

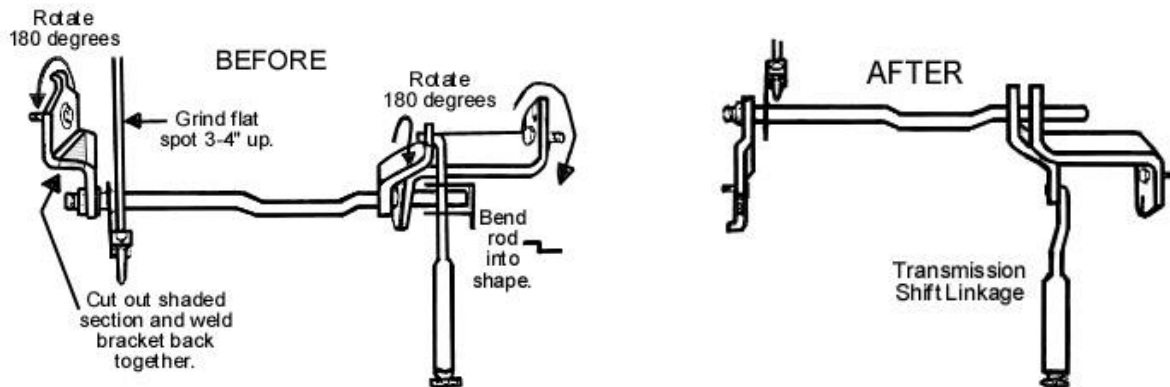

Figure B

Figure C

**LIMITATION OF LIABILITY – DISCLAIMER:**

The regulation of emissions production, noise levels, and safety standards is undertaken by the federal government, each of the fifty state legislatures, and by many local municipalities, towns, and counties.

HOKKER makes no warranties of merchantability, of fitness for particular purpose, or that its products are approved for general use, or that its products are approved for general use, or that its products comply with laws, regulations, or ordinances in the state where they may be sold to the ultimate purchaser, the consumer.

Unless expressly stated to the contrary in the catalog, instruction sheet; or price list, the entire risk as to the conformity of any company product in any such state and as to repair should the product prove to be defective or non-conforming, is on the retail purchaser, the buyer, the ultimate consumer, of such product and it is not upon the seller, distributor, or manufacturer.

In this connection, the retail purchaser, the buyer, the ultimate consumer assumes the burden of the entire cost of any and all necessary service, alterations, or repair.

**THE FOREGOING STATEMENT LIMITS THE LIABILITY OF THE MANUFACTURER.**

California vehicle code, sections 27156 and 38391, prohibits the advertising, offering for sale, or installation of any device, which modifies a vehicle's emission control system, unless exempted, unless otherwise noted. HOKKER™ Headers that have not received an Executive Order (E.O.) exemption from these code sections are not legal for sale or use in California on vehicles originally equipped with catalytic converters, except for racing vehicles, which may never be driven upon a highway. Check with your local authorities to determine if these headers are legal for use in your particular area.

**5901HKR**

**Revision Date: 2-2-15**