



QFT™ 260 PRO SERIES FUEL PUMP P/N 30-260

The **QFT™ 260 Pro Series Pump** is a completely rebuildable electric fuel pump providing 260 gallons of fuel per hour at 15 psi. **READ THE INSTRUCTIONS THOROUGHLY** and follow them to insure maximum performance from your **QFT™ Fuel Pump**. **THIS PUMP IS DESIGNED FOR COMPETITION USE ONLY. ANY USAGE IN STREET DRIVEN VEHICLES IS STRICTLY PROHIBITED.** **QFT™** recommends this pump be used with the 30-7025 regulator.

PUMP INSTALLATION:

Mounting

The best location for mounting your **QFT™ 260 Pro Series Fuel Pump** is as close to the fuel tank as possible. The fuel pump inlet should be level or below the fuel pickups if at all possible. **THE PUMP SHOULD NEVER BE MOUNTED IN THE DRIVER'S COMPARTMENT OR NEAR ANY HOT ENGINE COMPONENTS.** It should be mounted on a solid member, such as a chassis, in a vertical position; motor on top. A mounting bracket comes with the fuel pump. Do not allow the motor housing to touch any metal parts on the vehicle. This will affect the motor and pump performance.

Inlet

The fuel pump should be fed by a single #10 or equivalent line from the tank. This may require rework of your existing fuel cell. A **QFT™ 5000 (P/N 30-7007)** fuel filter should be installed before the pump as it will prolong pump life and does not restrict flow.

Outlet

The outlet side of the pump, going to the regulator, should be a single #8 or equivalent line.

Bypass

The return line should be plumbed with a single #8 or 1/2" line. The return should expel the bypassed fuel into the liquid rather than into the air space of the fuel cell. This will prevent aeration of the fuel. All fuel tanks and cells should have fuel cell foam installed to prevent fuel slosh.

WARNING: DO NOT BLOCK THE RETURN, VENT, OR PUMP FEED. MAKE SURE THAT THE SYSTEM IS LEAK FREE AT ALL CONNECTIONS...YOUR SAFETY DEPENDS ON IT!

Wiring

BEFORE MAKING ELECTRICAL CONNECTIONS, DISCONNECT THE POSITIVE TERMINAL FROM THE BATTERY.

Your **QFT™ 260 Pro Series Fuel Pump** should be connected to a fully charged 12 or 16 volt battery. A fuel pump, like any other electrical accessory, will only perform at its best when given adequate voltage. The black wire is a ground (-) and the remaining wire is a switched hot lead from a (+) 12 or 16 volt source. If wired incorrectly, the pump will run backwards and will not pump. A relay **MUST** be used for best performance and lower current draw from the battery. A 12 gauge wire should be used on the pump power supply and a 16 gauge wire from the switch to activate the relay. For best performance, keep all wiring runs as short as possible. Many electrical boxes now being sold will have circuits and fuses wired for smaller twin pumps, which is adequate if a relay is used. Power wiring to the pump should be capable of handling 25 amps as this will take care of the start-up voltage surge.

WARNING: ALL WIRING CIRCUITS SHOULD BE FUSED!!

TUNING AND ADJUSTMENT:

Be sure the tank is full and fuel is at pump inlet before attempting to run the pump. The pump should not be operated dry for extended periods. Pressure to the regulator is controlled by the bypass valve screwed into the outlet side of the fuel pump. Loosen the check nut on the bottom and the top barrel will turn clockwise or counter clockwise. Clockwise will increase pressure and counter clockwise will decrease pressure. Pressure can be checked at the pump from the 1/8" NPT tapped hole in the pump body. 13 to 16 PSI is usually sufficient for a hard leaving, front-mounted fuel cell car. Make sure to tighten the check nut after adjusting the fuel pressure. Check for leaks to insure your safety.

NOTE: BARREL SHOULD NOT BE MORE THAN 4 1/2 TURNS FROM SEATED (CLOCKWISE) POSITION OR LEAKAGE WILL OCCUR.

MAINTENANCE:

The following tips should be followed to insure maximum performance from your **QFT™** 260 Pro Series Fuel Pump:

1. Fuel pressure to the regulator and after the regulator should be checked before every racing event to assure proper fuel system operation.
2. If the vehicle is to be stored for long periods, it is recommended that the pump be operated, with fluid flowing, for several minutes weekly to keep fluid passages clean and the bypass working freely. The system may also be drained and the pump lubricated with a light oil spray to extend life.

Rebuild Kits are available for the **QFT™** 260 pump:

- P/N 30-7300 – **QFT™** 230 & 260 Pump Rebuild Kit
- P/N 30-7313 – **QFT™** 260 Pump Body & Seal Assembly

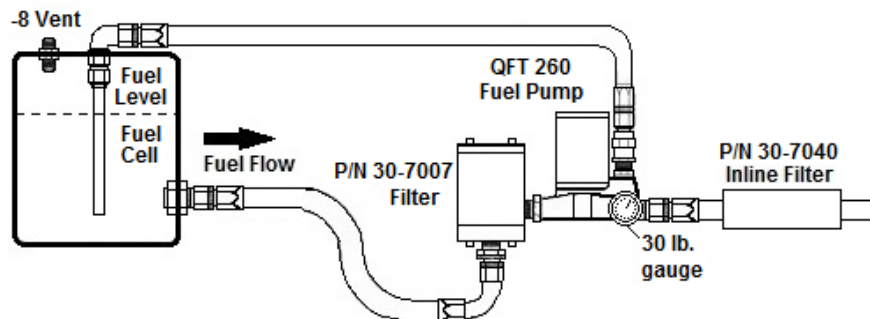

Figure 1

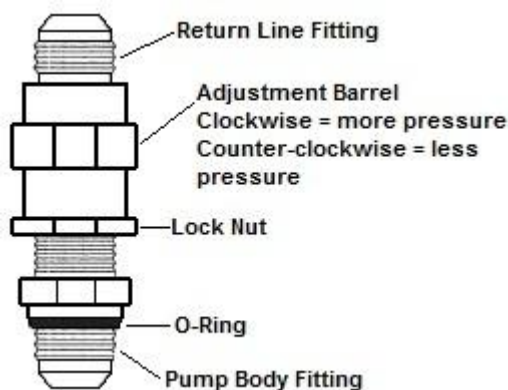

Figure 2

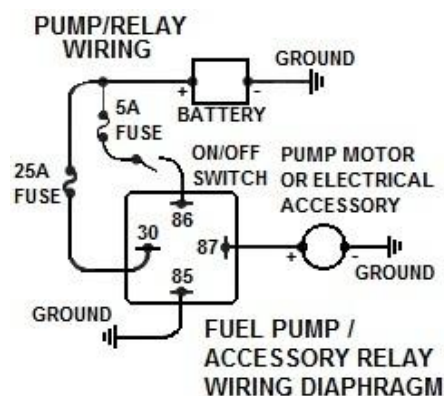

Figure 3

For warranty information, please see our website at www.quickfueltechnology.com.

For further questions, please contact our technical department at 1-270-793-0900.

99-30-260

Date: 9-5-13