



INSTALLATION INSTRUCTIONS AND TECHNICAL INFORMATION

FORM 1638 (REV. B) 10/04

52000 SERIES MAGNETIC BREAKERLESS DISTRIBUTORS

GENERAL INFORMATION

ACCEL 52000 distributors feature a magnetic triggering device with an adjustable mechanical advance as well as a totally independent adjustable vacuum advance. The electronic module is designed for use with 12-volt negative ground systems only.

ACCEL 52000 distributors are smog legal for specific applications. Contact the factory for applications that have been granted C.A.R.B. exemptions.

ACCEL 52000 distributors utilize an internal module and therefore do not require an external ignition box. However, the ACCEL 52000 series distributors are compatible with most ignition amplifier boxes (including those from ACCEL and Mallory) if a hotter spark is required.

Distributor Cap

ACCEL 52000 distributors are supplied with a male tower clip-on cap with HEI style spark plug wire connections and a wire retainer ring. If a more traditional style female tower distributor cap style is desired or required, then the ACCEL 52000 distributors can be fitted with an ACCEL tan cap and rotor kit p/n 8120. Please note that when changing to the traditional style female tower cap, that it is required that you change BOTH the cap (p/n 120124) and the rotor (p/n 130117). If a black female cap and rotor kit is desired, then use ACCEL p/n 8124.

Spark Plug Wires

Do NOT use solid metal core spark plug wires. Suppression type spark plug wires must be used (either carbon/graphite core or magnetic suppression spiral core). Solid core spark plug wires will cause false triggering and eventual module failure.

Coils

When installing your new ACCEL 52000 distributor, it is important to check the primary resistance of the coil. To do this, use an ohmmeter. With the ignition switch off, check across both the (+) and (-) terminals of the coil. The resistance value should be less than 1 ohm. If the resistance is greater than 1 ohm, you have a coil that was designed for a factory points style distributor. Using a coil that was designed for a points style ignition will cause the electronic module to overheat and fail. ACCEL recommends using a coil designed for an electronic breakerless ignition system, which ideally, has a primary resistance of less than 1 ohm. ACCEL coil part numbers 140001, 140008, 8145, or 8145C will work exceptionally well with the ACCEL 52000 distributors. Please note that an ACCEL 52000 Distributors should never be run with a CD Coil, without the use of a CD Control Box.

NOTE: Failure to use a coil with the proper primary resistance (less than 1 ohm) will void your warranty.

Reluctor to Magnetic Pickup Air Gap

The reluctor to magnetic pick-up air gap is preset on the ACCEL 52000 Series Distributors for optimum performance and triggering accuracy. It does not require any adjustment.

Distributor Drive Gear

ACCEL 52000 distributors are factory fitted with a steel alloy drive gear that is compatible with most flat tappet cams, as well as most factory type hydraulic roller cams. Some ACCEL 52000 distributors do not include a drive gear. If your application requires a drive gear, instructions are included on how to install your stock drive gear onto the ACCEL 52000 distributor.

If you are using a factory hydraulic roller camshaft, we suggest that you check for gear wear after the first 100 miles. If you are using an aftermarket roller camshaft, you may need to use a bronze distributor gear. Check with your camshaft supplier for additional information.

Welding

Disconnect the ACCEL 52000 distributor wire harness before welding on the vehicle.

Mechanical Advance

The ACCEL 52000 distributors are factory set to provide approximately 20° degree (crank) of mechanical advance, starting at about 900 RPM all in by about 2100 RPM. This is a good general-purpose curve and will work for most applications. If your engine has a higher static compression ratio or higher cylinder pressure from a super or turbo charger, or is used in a heavily loaded application such as a two vehicle or is equipped with racing type components, then the mechanical advance curve may need to be custom tailored to the your particular engines needs.

NOTE: Check local smog laws before changing the advance curve.

Selecting and Changing the Mechanical Advance

The cams, springs, stop bushings and weights all determine the mechanical advance curve. The starting point, amount and rate of the mechanical advance are adjustable. When the mechanical advance starts is controlled by the tension of the springs and their

installed length. How quickly the mechanical advance comes in (or the slope of the advance curve) is controlled by the stiffness of the springs. The stiffer the springs used, the slower the rate of the mechanical advance. The advance stop bushing controls the total amount of mechanical advance. The larger the size of the bushing used, the smaller the amount of total mechanical advance. You can also lock out the mechanical advance altogether if you wish.

The ACCEL 52000 distributors are equipped from the factory with two heavy gold springs. The parts kit included contains three additional pair of colored springs; black, silver and light weight gold. See advance curve charts Figures 2A through 2D.

Selecting and Changing the Advance Stop Bushing

There are three different advance stop bushings supplied in a kit with the ACCEL 52000 distributor. No stop bushings are factory installed which yields approximately 22° degrees of advance. If a different amount of mechanical advance is desired, see advance stop bushing chart figure #3 to select the stop bushing that meets your requirements. To change the mechanical advance stop bushing, first remove the cap and rotor. Although it is not absolutely necessary, it is easier if you also remove the advance springs and weights from the advance assembly, see figure #4 and also remove the roll pin from the drive gear, remove gear and thrust washer from the shaft (if so equipped). Make sure not to misplace the roll pin and thrust washer. Lift the shaft

assembly out of the distributor about two inches. If necessary, push the pickup plate back down. Now you have better access to remove the retainer clip on the bottom of the advance assembly, see figure #5. Install a stop bushing and reinstall the retainer clip. If you have disassembled the shaft and advance assembly, reassemble them in the reverse order.

Locking out the Mechanical Advance

You may also decide to run the ACCEL 52000 distributor with a locked out mechanical advance. To do so, first remove the cap and rotor. Remove the advance springs and weights from the advance assembly. Remove the roll pin from the drive gear, remove gear and thrust washer from the shaft (if so equipped). Make sure not to misplace the roll pin and thrust washer. Lift the shaft assembly out of the distributor about two inches. Remove the retaining clip and the stop advance bushing, if any are installed. Rotate the shaft assembly 180 degrees and reposition the stop bushing pin into the small hole in the pickup plate using a slight amount of pressure. This is a press fit to maintain stable timing. See figure #6. Reinstall the thrust washer, drive gear and roll pin.

Vacuum Advance

The vacuum advance operates independently from the mechanical advance. The vacuum chamber is factory adjusted to

FIGURE 2A

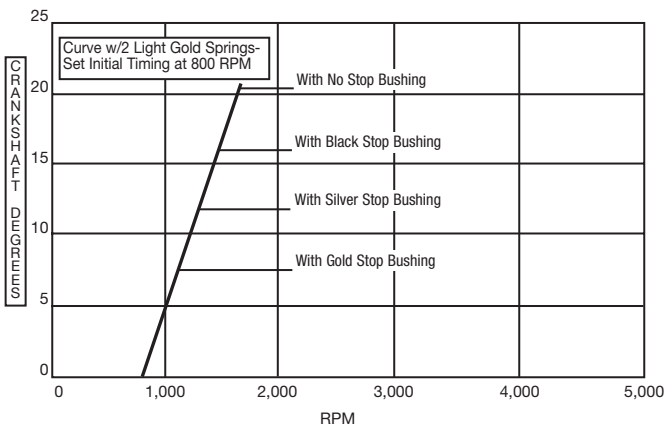

FIGURE 2B

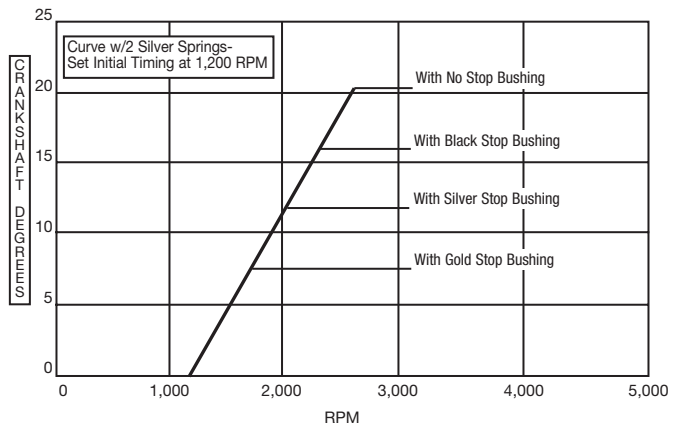

FIGURE 2C

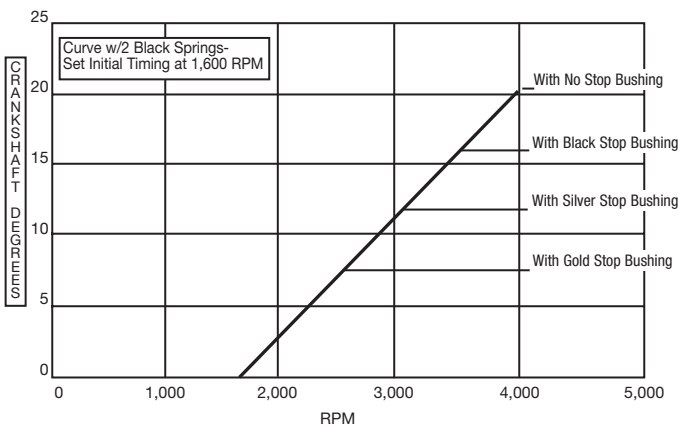
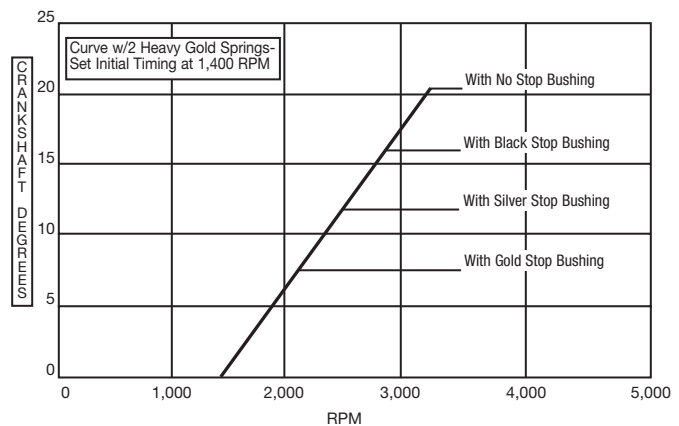

FIGURE 2D



Advance Stop Bushing Chart

| BUSHING SIZE | APPROXIMATE CRANKSHAFT DEGREES |
|-----------------|--------------------------------|
| Black- Smallest | 16 |
| Silver- Medium | 12 |
| Gold- Largest | 8 |

FIGURE 3

Changing the Advance Stop Bushing

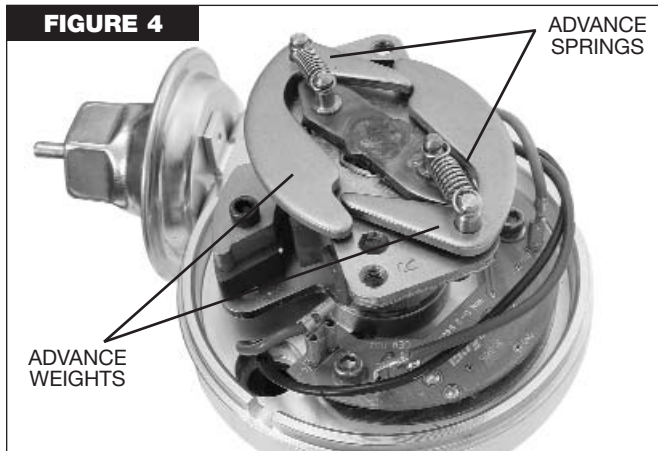

FIGURE 4

Locking Out the Advance

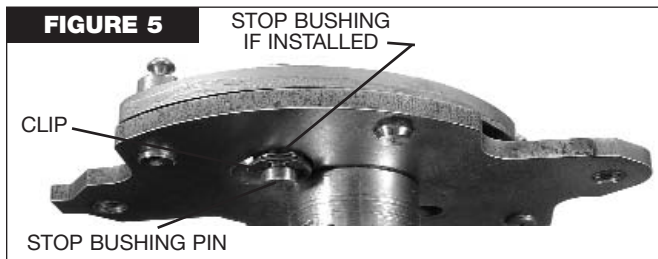

FIGURE 5

produce 10° advance (crank) at 10" of vacuum. The vacuum advance can be adjusted by inserting a 3/32" Allen wrench into the hose nipple on the vacuum chamber. Turn the wrench clockwise to increase advance, counterclockwise to decrease. See figure #7.

NOTE: Check local smog laws before adjusting the vacuum advance.

In most cases, the vacuum advance hose should be connected to a ported vacuum outlet on the carburetor. This is the same location as stock. However, in some cases where a very large camshaft is used, connecting the vacuum hose to full manifold vacuum (near the bottom of the carburetor) will improve idle.

Vacuum Advance Lockout

If the vacuum advance is not going to be used (such as for racing), the vacuum advance chamber can be removed and replaced with the enclosed lockout. The lockout covers the hole in the distributor housing and prevents the pickup plate from rotating.

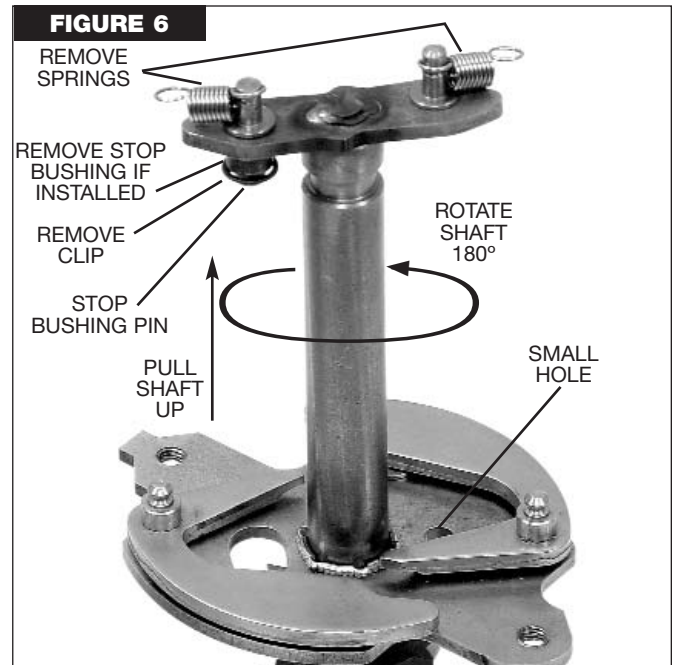

FIGURE 6

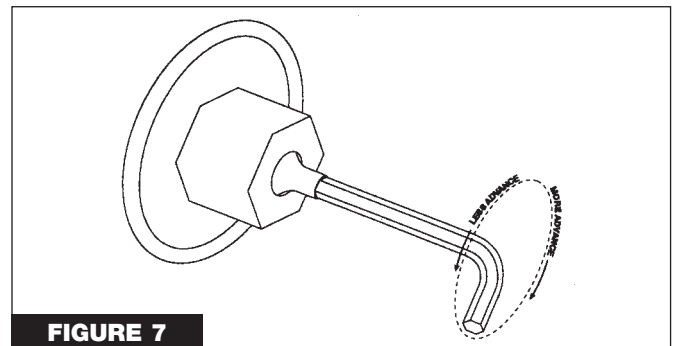

FIGURE 7

To remove the vacuum chamber, you must remove the distributor gear (and lower collar if so equipped) and remove the shaft assembly. Remove the clip holding the pickup mounting plate assembly. Next, remove the 2 screws holding the vacuum chamber and the clip on the control rod. Place the lockout plate in the distributor, making sure the pin projects through the hole in the pickup plate assembly. Secure the lockout with the 2 screws and retaining clip. Re-assemble the distributor.

NOTE: Check local smog laws before removing the vacuum advance chamber.

INSTALLATION

Installing an ACCEL 52000 distributor and setting the timing is done in much the same way as a stock distributor (see a repair manual for more information). If another distributor is already installed (and correctly timed) note the direction the rotor is pointing before removing the distributor. Transfer the plug wires to the ACCEL cap in the same order and relative locations. Install

the ACCEL 52000 distributor so that the rotor points to the same plug wire as the previous distributor. This should make the timing close enough to start the engine. Also make sure you set and/or verify the initial timing advance at an engine speed of 800 RPM.

WIRING

When you are using your distributor without an ignition amplifier or CD type ignition unit, the 3-wire harness connects as follows:

Brown Wire Negative (-) Terminal on the Coil
Black Wire Engine Ground
Red Wire Switched 12 Volt Source

Note- Some older vehicles are equipped with a ballast resistor or a resistance wire. These cannot be used with this distributor. Bypass or eliminate the ballast resistor if your vehicle is equipped with one. To check for a resistance wire, use a voltmeter to verify that when the engine is running that the COIL POSITIVE TERMINAL reads within 1 volt of the battery voltage. If the voltage difference is more than 1 volt, the wire needs to be replaced. When bypassing a ballast resistor or eliminating a resistance wire, use at least a 14 gauge automotive grade copper wire from the COIL POSITIVE (+) to the starter solenoid or a switch terminal in the fuse box.

Make sure that your 12-Volt source supplies voltage with the ignition key in both with the ON (run) and START positions, but not in the ACCESSORY position.

Connecting to ACCEL 300+ Ignition

Or other CDI box, ignition amplifier, or multiple strike unit.

Your new distributor is designed as a stand-alone unit. It does not require an external ignition/enhancer box to operate. To use the ACCEL 300+ (or other) ignition system with this distributor, the electronic module must be bypassed.

Step 1

Remove the cap and rotor.

Step 2

The breakerless electronic module is the green, half-circle shaped piece with four wires attached to it. Remove the four wire leads (one red, one green, one orange, one purple) from the module. They are attached with spade connectors.

The module may be removed from the distributor, if desired.

Step 3

Connect the two leads from the magnetic pickup directly to the ACCEL 300+. Connect the purple lead from the magnetic pickup to the ACCEL 300+ purple lead (magnetic pickup positive +). Connect the orange wire from the magnetic pickup to the ACCEL 300+ orange lead (magnetic pickup negative -).

Step 4

Other 300+ connections:

| | |
|--------|-------------------------|
| Red | 12 volts key (ignition) |
| Black | Engine Ground |
| Yellow | 300+ Coil Positive (+) |
| Brown | 300+ Coil Negative (-) |

Step 5

Follow instructions in the ACCEL 300+ booklet regarding spark plug gap and ignition timing under "Technical Tips and Hints" section.

REPLACEMENT PARTS

| | |
|-------------------------------|--------|
| Cap, Tan | 120405 |
| Rotor, Tan | 130405 |
| Cap and Rotor Kits: | |
| Tan | 8348 |
| Blue | 8348B |
| Red | 8348R |
| Black | 8348K |
| Electronic Module | 35372 |
| Vacuum Chamber | 29332 |
| Harness | 29349 |
| Blue & White Magnetic Pick-up | 31086 |



ACCEL IS A DIVISION OF THE MR. GASKET PERFORMANCE GROUP
10601 MEMPHIS AVE #12, CLEVELAND, OH 44144
216.688.8300 FAX 216.688.8306

FORM 1638
(REV. B) 10/04
Made in U.S.A.
Printed in U.S.A.