

Detroit Speed
1970-1981 Camaro/Firebird LS Engine Mount Kit
Detroit Speed Hydroformed Subframe
P/N: 060414DS

The Detroit Speed LS Engine Mount Kit provides an ideal mounting solution for the LSx conversion into the Detroit Speed Hydroformed Subframe for the 1970-1981 Camaro/Firebird.



Item	Description	Quantity
1	Engine Mount Adapter Plate, LH & RH	2
2	Frame Stand, LH & RH	2
3	Polyurethane Engine Mounts	2
4	M10-1.5 x 30 Countersunk Bolt	2
5	M10-1.5 x 30 Flange Head Bolt	4
6	M10-1.5 x 20 Flange Head Bolt	4
7	M10-1.5 x 40 Flange Head Bolt	2
8	M10 Flat Washer	10
9	7/16"-14 x 3-3/4" L Hex Head Bolt	2
10	7/16"-14 Hex Nut	2
11	7/16" Flat Washer	4
12	7/16" Lock Washer	2
13	3/8"-16 x 1.0" L Hex Head Bolt	10
14	3/8" Flat Washer	10

Fastener Torque Specifications	
Application	Torque (ft. /lbs.)
Adapter Plate to Engine Block (Aluminum Block)	25
Adapter Plate to Engine Block (Cast Iron Block)	35
Engine Mount to Adapter Plate (Upper Bolts)	25
Engine Mount to Adapter Plate (Lower Bolt - Aluminum Block)	25
Engine Mount to Adapter Plate (Lower Bolt - Cast Iron Block)	35
Frame Stand to Detroit Speed Hydroformed Subframe	35
Frame Stand to Engine Mount	30

1. Locate the engine mount adapter plates in the kit. The milled side of the mount faces away from the engine with the smooth side going to the block. The end of the adapter plate with the angle cut mounts to the front of the vehicle.
2. Mount the engine mount adapter plate to the engine, use two M10-1.5 x 30 flange head bolts (#5), two M10 washers (#8) and one M10-1.5 x 30 countersunk bolt (#4) per side. Use anti-seize on these bolts. On aluminum engine blocks, torque the bolts to 25 ft. /lbs. and on cast iron blocks, torque to 35 ft. /lbs.
3. The engine mount is installed next. Use two M10-1.5 x 20 flange head (#6) bolts and two M10 washers (#8) in the top of the mount. Install one M10-1.5 x 40 flange head bolt (#7) in the bottom of the mount. Again, use anti-seize on these bolts. Torque the upper bolts into the adapter plate to 25 ft. /lbs. For the lower bolt, torque to 25 ft. /lbs. on an aluminum block and 35 ft. /lbs. on a cast iron block.
4. Attach the frame stands to the subframe using five 3/8"-16 x 1.0" L hex head bolts (#13) and five 3/8" flat washers (#14) per side. There is a LH and RH stand. Follow the pictures in Figure 1 for proper orientation. Use High Strength Loctite (p/n: 262) on these bolts when installing and torque the bolts to 35 ft. /lbs.

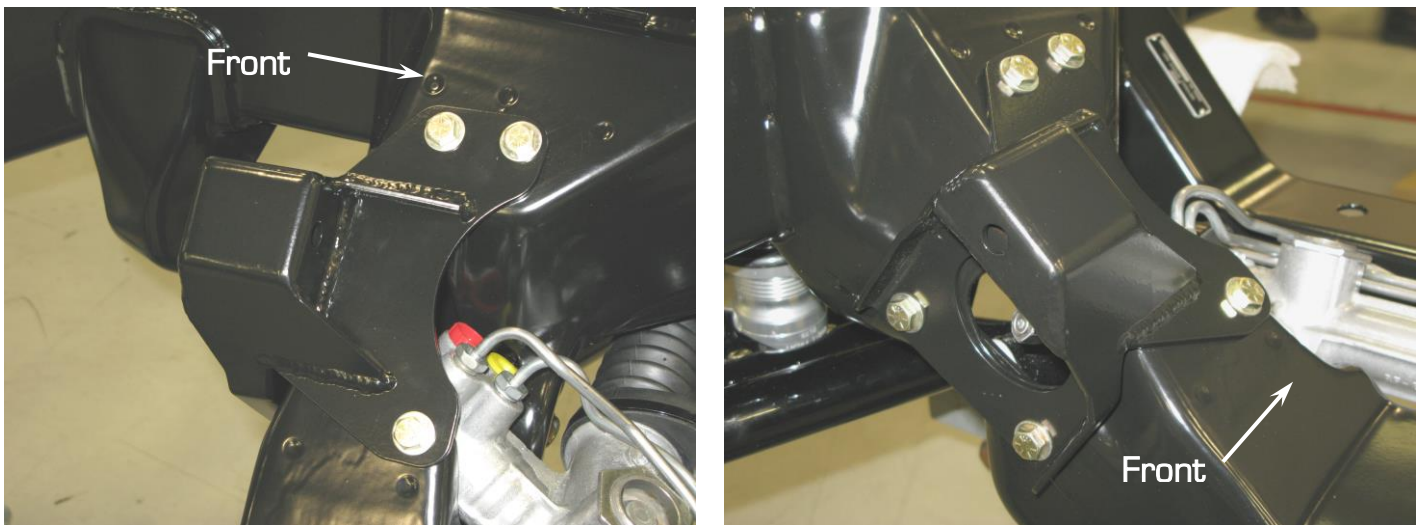

Figure 1 - Engine frame stand installed on the Detroit Speed Hydroformed Subframe, Driver Side

5. Once everything is positioned correctly on the frame and engine, attach the engine to the frame using two 7/16"-14 x 3-3/4" L hex head bolts (#9). Use the provided 7/16" flat washers (#11), 7/16" lock washer (#12) and the 7/16"-14 hex nuts (#10) to tighten everything in place. Torque these bolts to 30 ft. /lbs. Figure 2 on the next page shows an assembled view.

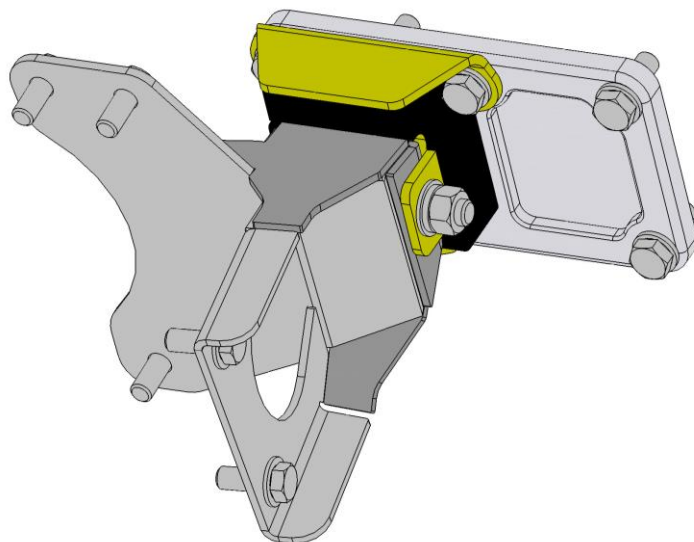

Figure 2 – Assembled View

To complete your project and the installation of the engine, Detroit Speed, Inc. has a header package available for this application. The headers are available as P/N: 061001DS. A picture of the headers can be seen below in Figure 3.



Figure 3 – Detroit Speed Headers

If you have any questions before or during the installation of this product, please contact Detroit Speed at tech@detroitsspeed.com or 704.662.3272