



**P/N 16552HKR (header dual) & 16652HKR (manifold dual)
1970-93 Dodge 1/2 or 3/4 Ton Truck (2 & 4WD) 318-360 cid
HOOKER COMPETITION EXHAUST SYSTEMS**

- NOTE:**
1. This system is designed to accommodate the factory-supplied catalytic converter.
 2. P/N 16552HKR was designed to be used with Hooker Competition Headers, P/N 5902HKR. If the dual exhaust is being installed with headers other than 5902HKR, modifications will be required. Hooker Headers will not assume responsibility for fit or performance.
 3. Mufflers are not supplied with this exhaust system. Hooker Headers has designed this kit in conjunction with Hooker Turbo Muffler (21005HKR) or any equivalent 2 1/4" ID inlet by 2 1/4" ID outlet single OEM muffler. Glasspack mufflers may be used with slight modifications.
 4. Dual kit fits only a standard 16 gallon gas tank.
 5. Dual kit will not fit Club Cab, but fits full-time 4x4 only.

BEFORE STARTING:

Your vehicle must be raised a minimum of 36 inches. A floor hoist is ideal. If no hoist is available, we strongly urge the use of axle stands as a safety measure. **CAUTION! Your car should NOT be supported on a bumper jack!** We recommend welding all pipe slip joints (headpipe to muffler, etc.). If no welding equipment is available at the time of installation, use the furnished clamps to secure the pipes until they can be welded.

INSTALLATION PROCEDURE – PLEASE READ CAREFULLY:

1. Remove the existing headpipe crossover and the single exhaust system. Cut the headpipe and remove the flanges for reuse on the new headpipes.
2. Install the left side headpipe (both 2 x 4 and 4 x 4) using the old flanges. Tighten only enough to hold in place. Slip the left side headpipe extension over the headpipe and rotate into position, using a 2 1/4" U-clamp. **DO NOT COMPLETELY TIGHTEN.** On header duals, install the left side headpipe using the collector gaskets provided. **DO NOT TIGHTEN.** See Figure A for headpipe location.
3. Install the right side headpipe and extension using the old flange and 2 1/4" U-clamp. **DO NOT TIGHTEN.** We do not recommend that a long oil filter be used. Use the OEM short filter. On header duals, install the right side headpipe using the collector gaskets provided.
4. Install the mufflers on the end of the headpipe extensions. Put the clamp in place and snug up, but **DO NOT TIGHTEN.** Rotate the mufflers to clear the drive shaft and frame (see **Figure A** for proper position). Over the rear of the mufflers, you will find a crossmember that a hole can be drilled in to accept a 5/16" bolt, 90° bracket, and rubber hanger.
5. Install the left and right tailpipe extension.

NOTE: This kit is designed to fit pickups with a 131" wheelbase. Should your pickup have a shorter wheelbase, it will be necessary to remove some length. This can be done by cutting it out of the straight section on the left side headpipe extension and not using the right side headpipe extension.

6. Install the tailpipes and center bump over the rear axle housing for maximum clearance (See Figure A). It may be necessary to move the spare tire carrier-mounting bolt back to the left side to clear the tailpipe.
7. As the tailpipe goes under the frame on its way out to the rear of the vehicle, find a hole in the area, or drill a new hole to bolt the rubber hanger to. See Figure A for the tailpipe location. Cut the end of the tailpipe for the desired length.
8. Make sure that all the parts of the system are clear of frame members, all hoses, suspension, and brake lines. Starting at the headpipes on the headers, tighten all the connections, making sure all the parts are clear and will not leak or rattle.

WARNING! The removal of catalytic converters and other factory air pollution control devices is illegal. We recommend that you abide the law. Our testing indicates that these devices do not significantly affect performance.

9. Start the engine and check for leaks. Be sure that all brake lines, fuel lines, and electrical wires have sufficient clearance. Reroute as necessary.
10. When finished, give your car a test drive, checking carefully for any new noises. After several days of driving, retighten all the bolts.

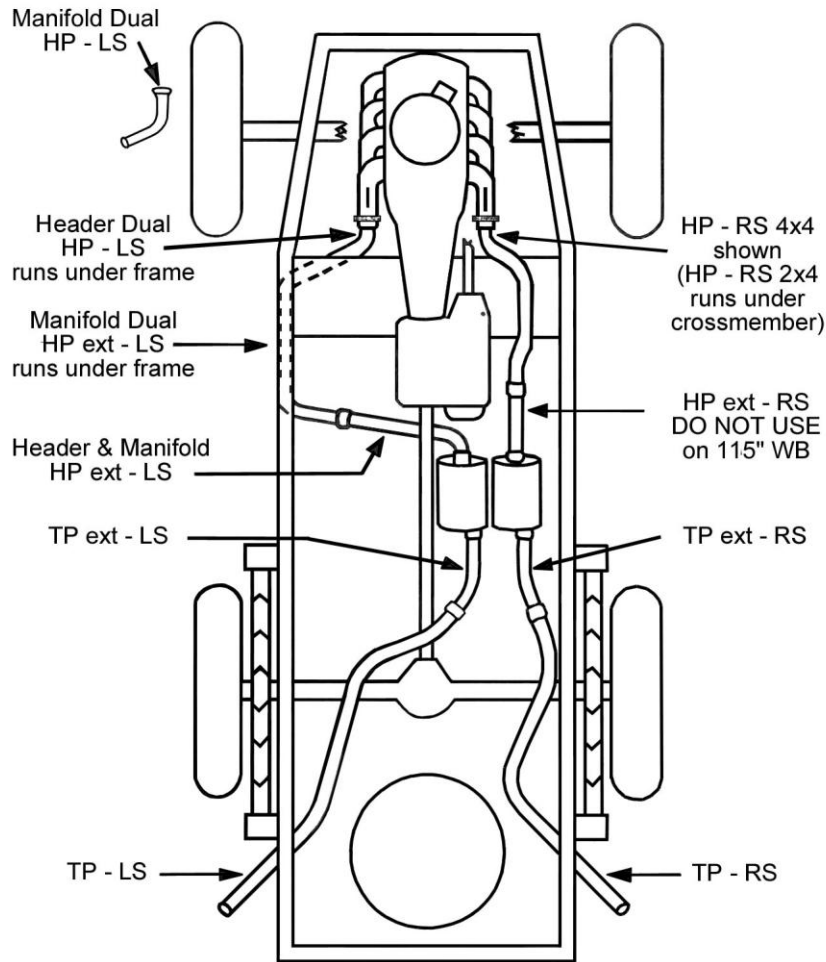

P/N 16552HKR INSTALLATION SHOWN
P/N 16652HKR IS SIMILAR

Figure A

LIMITATION OF LIABILITY – DISCLAIMER

The regulation of emissions production, noise levels, and safety standards is undertaken by the federal government, each of the fifty state legislatures, and by many local municipalities, towns, and counties. HOOKER Industries makes no warranties of merchantability, of fitness for particular purpose, or that its products are approved for general use, or that its products comply with laws, regulations, or ordinances in the states where they may be sold to the ultimate purchaser, the consumer. Unless expressly stated to the contrary in the catalog, instruction sheet, or price list, the entire risk as to the conformity of any company product in any such state and as to repair should the product prove to be defective or nonconforming, is on the retail purchaser, the buyer, the ultimate consumer, of such product and it is not upon the seller, distributor, or manufacturer. In this connection, the retail purchaser, the buyer, the ultimate consumer assumes the burden of the entire cost of any and all necessary service, alterations, or repair.

The foregoing statement limits the liability of the manufacturer.

California vehicle code, sections 27156 and 38391, prohibits the advertising, offering for sale, or installation of any device, which modifies a vehicle's emission control system, unless exempted, unless otherwise noted. HOOKER Headers that have not received an Executive Order (E.O.) exemption from these code sections are not legal for sale or use in California on vehicles originally equipped with catalytic converters, except for racing vehicles, which may never be driven upon a highway. Check with your local authorities to determine if these headers are legal for use in your particular area.

HOOKER TECHNICAL SUPPORT
Toll-Free Phone: 1-866-GOHOLLEY
Phone: 1-270-781-9741 Fax: 1-270-781-9772

For online help, please refer to the Tech Service section of our website: www.holley.com

16552HKR & 16652HKR
Revision Date: 10-26-12