

© 1982 TECHLIT CO. Printed in U.S.A.

# INSTRUCTION SHEET

## ROCHESTER CARBURETOR - MODELS 4MC-4MV

50-360-2

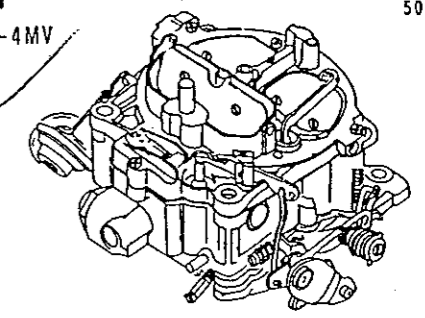

### GENERAL EXPLODED VIEW

THE GENERAL DESIGN AND PARTS SHOWN WILL VARY TO INDIVIDUAL UNITS COVERED ON THIS INSTRUCTION SHEET

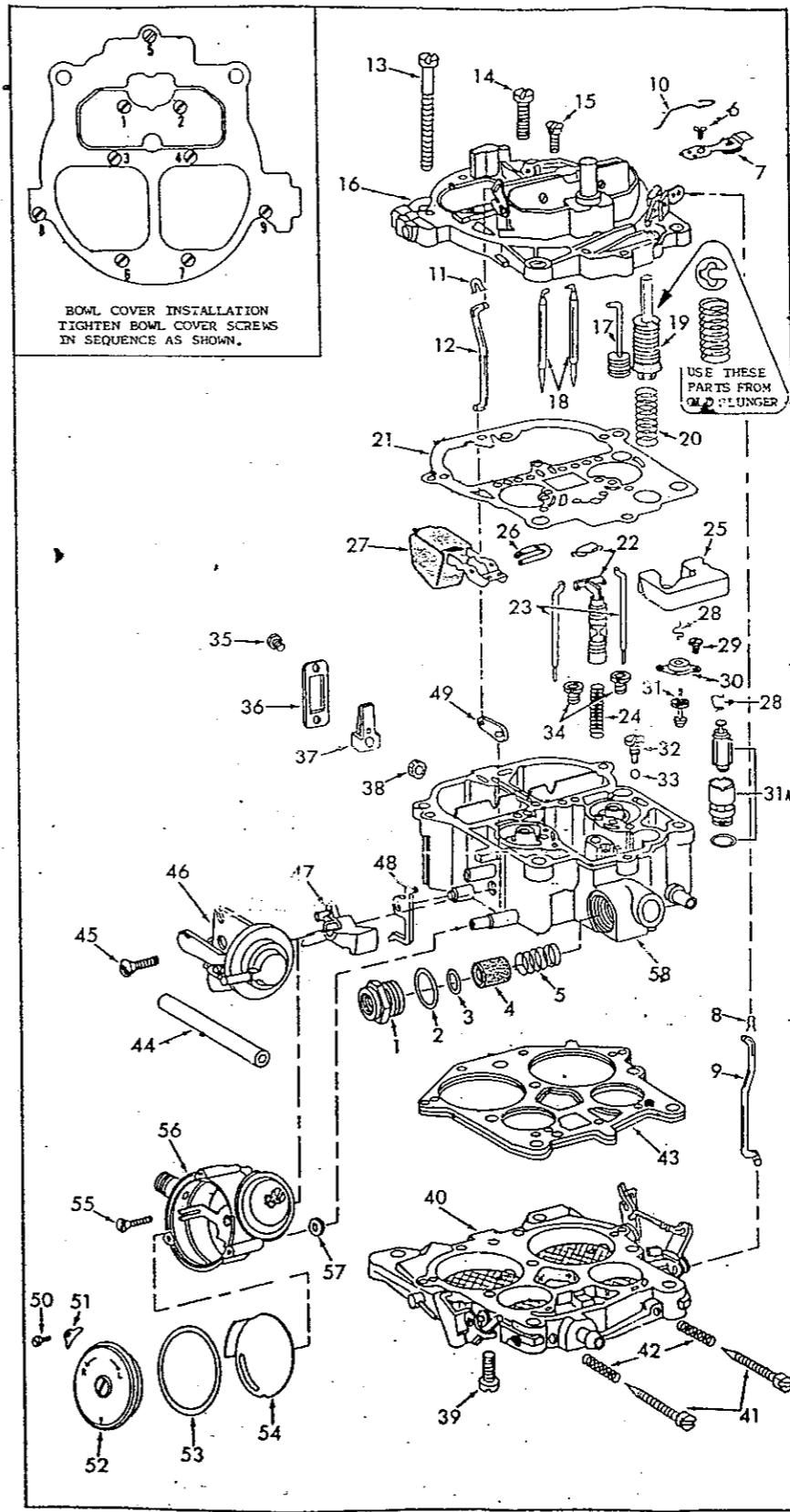

### DISASSEMBLY

USE EXPLODED VIEW AS A GUIDE. THE NUMERICAL SEQUENCE MAY GENERALLY BE FOLLOWED TO DISASSEMBLE UNIT FAR ENOUGH TO PERMIT CLEANING AND INSPECTION. NOTE: REMOVING BOWL COVER (16) (GASKET (21) STAYS ON BOWL.) LIFTING STRAIGHT UP BEING CAREFUL NOT TO BEND AIR BLEED TUBES WHICH ARE PERMANENTLY INSTALLED IN BOWL COVER. AIR VALVES, AIR VALVE SHAFT AND SECONDARY METERING ROD HANGER ARE CALIBRATED AND SHOULD NOT BE REMOVED. REMOVING POWER PISTON (22) AND METERING RODS (23) PULL STRAIGHT UP ON METERING ROD HANGER. A SLIGHT RESISTANCE WILL BE FELT. POWER PISTON (22) HAS A HOLDING CLIP TO KEEP ASSEMBLY IN PLACE FOR EASIER ASSEMBLY. INLET NEEDLE SEAT USED WITH NO. 31 NEEDLE AND ALL SECONDARY METERING DISCS ARE FACTORY STAKED AND SHOULD NOT BE REMOVED.

### NOMENCLATURE

REF. NO.	REF. NO.
1. FILTER NUT - FUEL INLET	33. BALL - PUMP DISCHARGE
2. GASKET - FILTER NUT	34. JETS - PRIMARY (2)
3. GASKET - FUEL FILTER	35. SCREW - IDLE COMPENSATOR COVER (2)
4. FILTER - FUEL INLET	36. COVER - IDLE COMPENSATOR
5. SPRING - FUEL FILTER	37. IDLE COMPENSATOR ASSY.
6. SCREW - IDLE VENT VALVE	38. GASKET - IDLE COMPENSATOR
7. VALVE - IDLE VENT	39. SCREW - THROTTLE BODY (3)
8. RETAINER - PUMP ROD	40. THROTTLE BODY ASSY.
9. ROD - PUMP	41. NEEDLES - IDLE ADJ. (2)
10. LEVER - IDLE VENT VALVE	42. SPRINGS - IDLE ADJ. NEEDLE (2)
11. RETAINER - CHOKE ROD	43. GASKET - THROTTLE BODY
12. ROD - CHOKE	44. HOSE - VACUUM 4MV
13. SCREW - AIR HORN (4)	45. SCREW - VACUUM BREAK CONTROL BRACKET ATTACHING
14. SCREW - AIR HORN (3)	46. VACUUM BREAK CONTROL & BRACKET ASSY. 4MV
15. SCREW - AIR HORN (2)	47. CAM - FAST IDLE
16. BOWL COVER ASSY.	48. LEVER - SEC. LOCKOUT 4MV
17. DASHPOT PISTON & ROD ASSY. 1965-66	49. LEVER - INTERMEDIATE CHOKE
18. METERING RODS - SEC. (2)	50. SCREW - STAT RETAINER (3) 4MC
19. PUMP ASSY.	51. RETAINERS - STAT COVER (3) 4MC
20. SPRING - PUMP RETURN	52. STAT COVER & SPRING ASSY. 4MC
21. GASKET - AIR HORN	53. GASKET - STAT COVER 4MC
22. POWER PISTON ASSY. - PRI. (2)	54. PLATE - CHOKE BAFFLE 4MC
23. METERING RODS - PRI. (2)	55. SCREW - STAT HOUSING ATT.
24. SPRING - POWER PISTON	56. HOUSING - CHOKE & VACUUM BREAK ASSY. 4MC
25. INSERT - FLOAT BOWL	57. GASKET - CHOKE HOUSING 4MC
26. HINGE PIN - FLOAT	58. BOWL ASSY. - FLOAT
27. FLOAT & LEVER ASSY.	
28. PULL CLIP - FLOAT NEEDLE	
29. SCREW - NEEDLE DIAPHRAGM RETAINER (2)	
30. RETAINER - NEEDLE DIAPH.	
31. NEEDLE & DIAPHRAGM ASSY.	
31A. NEEDLE, SEAT, GASKET ASSY.	
32. PLUG - PUMP DISC. BALL	

### CLEANING

CLEANING MUST BE DONE WITH CARBURETOR DISASSEMBLED. SOAK PARTS LONG ENOUGH TO SOFTEN AND REMOVE ALL FOREIGN MATERIAL. USE (1) A CARBURETOR CLEANING SOLVENT, (2) LACQUER THINNER OR (3) DENATURED ALCOHOL. MAKE CERTAIN THE THROTTLE BORES ARE FREE OF ALL CARBON DEPOSITS. RINSE OFF IN SUITABLE SOLVENT. BLOW OUT ALL PASSAGES IN CASTINGS WITH COMPRESSED AIR AND CHECK CAREFULLY TO INSURE THOROUGH CLEANING OF OBSCURE AREAS. CAUTION: DO NOT SOAK RUBBER OR PLASTIC PARTS IN SOLVENT. (FLOAT (27) VAC BREAK UNITS (46) (56) DASHPOT PISTON (17) PUMPS (19) BOWL VENT (7).)

### REASSEMBLY

REASSEMBLE IN REVERSE ORDER OF DISASSEMBLY. NOTE SPECIAL INSTRUCTIONS AND FOLLOW NUMERICAL OUTLINE IN MAKING ADJUSTMENTS. SEE OTHER SIDE.

### SPECIAL INSTRUCTIONS

VACUUM BREAK CONTROL AND BRACKET ASSY. (46) OR VAC. UNIT (56) INSTALLATION. BE SURE FAST IDLE CAM (47), SECONDARY LOCKOUT LEVER (48) WHEN USED, AND GASKET (57) WHEN USED, AND INTERMEDIATE CHOKE LEVER (49) ARE IN PROPER PLACE BEFORE TIGHTENING SCREW (45) OR (55).

IDLE ADJUSTING NEEDLES (41). TURN EACH NEEDLE IN TO SEAT LIGHTLY AND THEN BACK OUT 3-4 TURNS.

POWER PISTON AND METERING ROD INSTALLATION. BE CAREFUL TO PROPERLY POSITION METERING RODS IN METERING JETS. PRESS FIRMLY DOWN ON POWER PISTON TO INSURE EITHER ENGAGEMENT OF RETAINING PIN IN THROTTLE BODY GASKET OR POWER POSITIONING OF SPRING CLIP USED ON PISTONS IN SOME MODELS.

BOWL COVER INSTALLATION. CAREFULLY POSITION SECONDARY METERING RODS AND VENT TUBES THROUGH AIR HORN GASKET. (DO NOT FORCE.) POSSIBLE DAMAGE TO SECONDARY METERING DISC. USE SLIGHT SIDEWARD MOVEMENT TO CENTER RODS IN JETS.

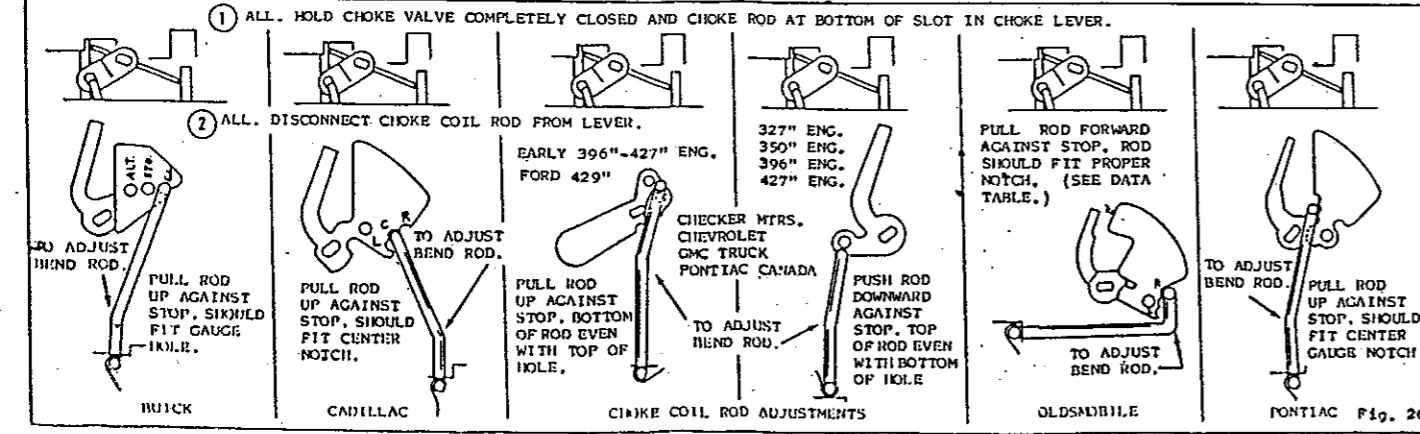
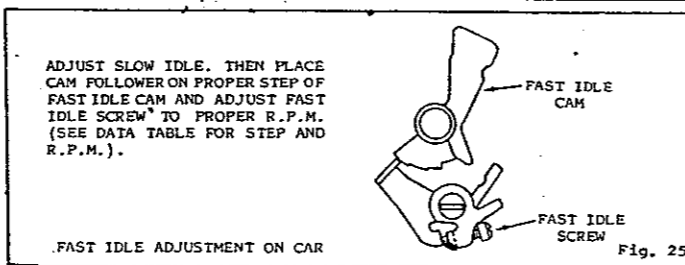
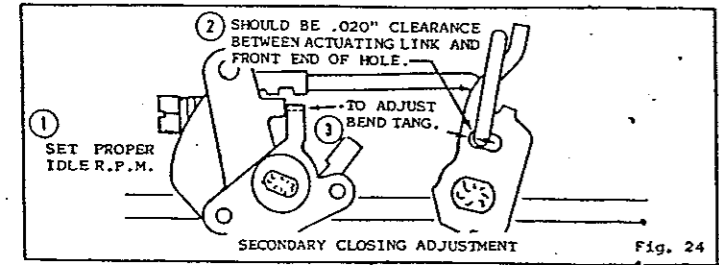
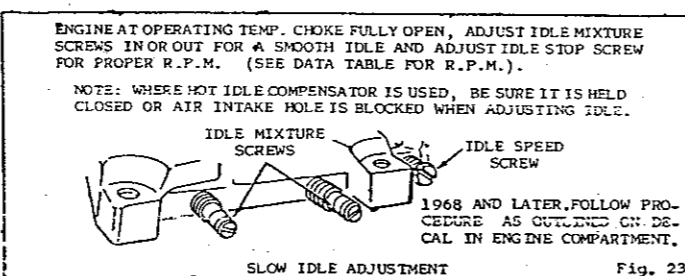
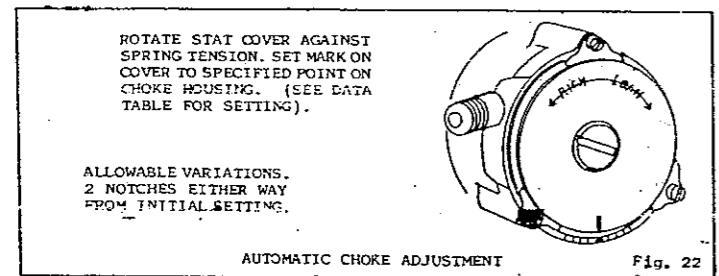
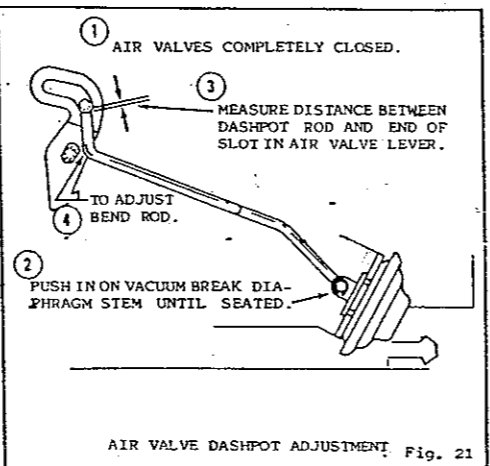
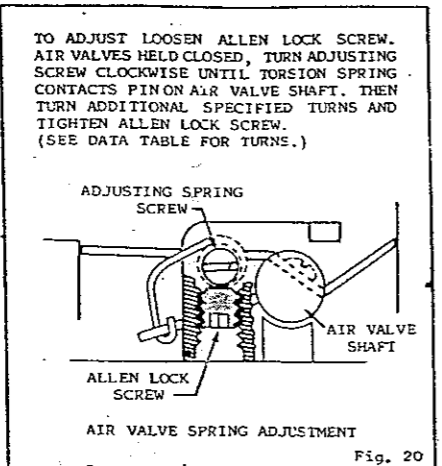
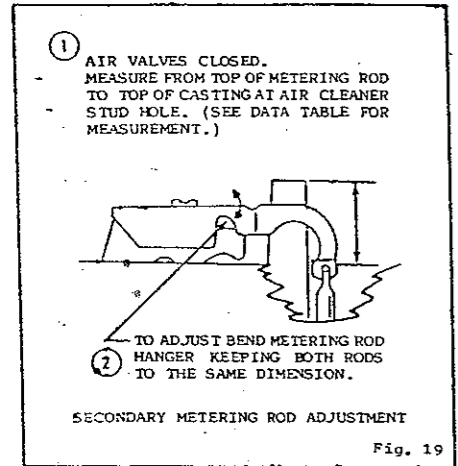
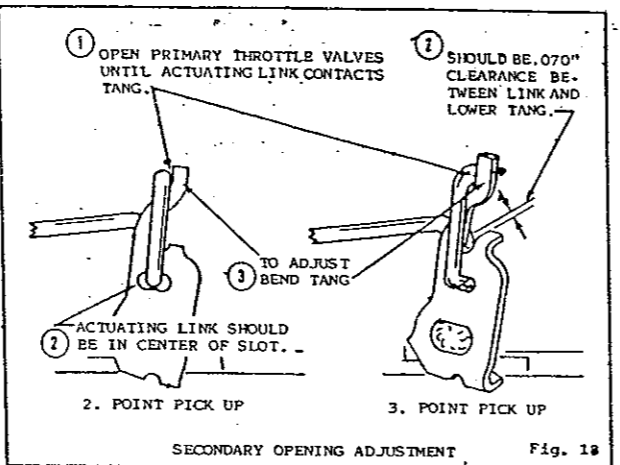
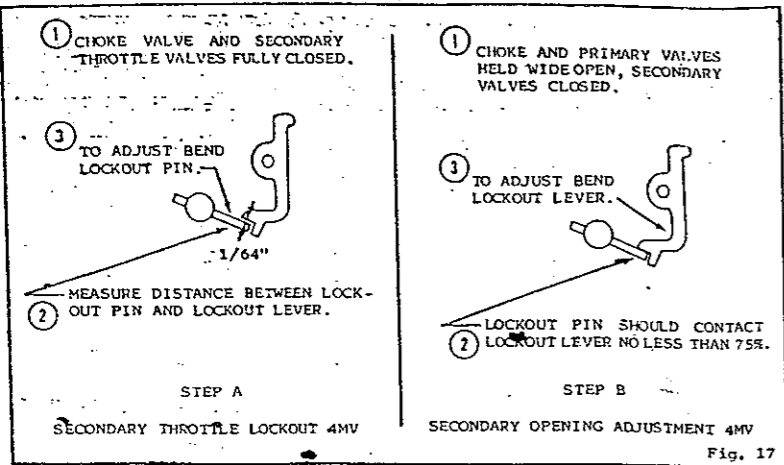

ADJUSTMENTS

