



Competition Header - 2451HKR (Black Paint), 2451-1HKR (Silver Ceramic), 2451-2HKR (Stainless), 2451-3HKR (Darkside Black Ceramic), and 2451-4HKR (Titanium Ceramic)

Fits 67-81 Camaro, 65-89 Chevy Full Size Car, 64-87 Chevelle/El Camino, 70-87 Monte Carlo, 68-79 Nova, 78-81 Pontiac Firebird/Trans Am, 77-87 Phoenix/Ventura/Grand Prix, 78-87 Olds Cutlass/442

Important Technical Information Before Starting Installation

This header is designed to fit multiple vehicle applications. As such, the collectors exit at two different heights in order to accommodate them all. If you are looking for a header with more available ground clearance, please check out part number 2466HKR or the Super Competition header designed specifically for your vehicle.

Factory style motor mounts must be used to ensure proper engine locations and header fit. Aftermarket solid and urethane mounts, worn or incorrect mounts will cause header fitment issues. If you have floor pan clearance issues on the pass side header, check your sub-frame mounts.

This header will not fit with close ratio steering box or rack conversions. Lowered ride height may result in insufficient ground clearance Check (2466HKR or Super Competition header for your vehicle).

This header was designed around the factory small block engine with factory heads. Raised port heads, D-port heads or non-stock plug locations may cause gasket leaks and header fitment issues that require modification to fit. This header will not work with angle plug heads.

Do not modify this header. If you modify the header, you will VOID the warranty.

WARNING! Breaking in an engine with ceramic-coated headers WILL result in damage to the coating and will VOID all warranties. Ceramic-coated headers require several heat cycles to fully cure before they will withstand extreme heat. Hooker® recommends using cast iron exhaust manifolds or old headers to break in new engines to avoid coating damage. Please call the Holley tech service at 1-866-464-6553 for additional information regarding ceramic-coated exhaust products.

BEFORE STARTING

Your vehicle must be raised a minimum of 36 inches. A floor hoist is ideal. If no hoist is available we strongly urge the use of axle stands as a safety measure.

CAUTION! Your car should not be supported on a bumper jack prior to installing headers, take the time to make a careful and complete inspection of both engine and transmission mounts. Replace them if they look worn or damaged, otherwise this may affect the header fitting into your vehicle properly.

LEFT SIDE

1. Disconnect the battery cable to prevent damage to the electrical systems.
2. Unbolt the headpipe from the stock cast iron manifold and push aside.
3. Remove the spark plugs, alternator, clutch linkage, oil filter, dipstick tube, and (on late model cars) unbolt the power steering bracket. 1976 models may not require oil filter position.
4. Starting from below, work the header up through the chassis into position.
5. Place the gasket into position and start all bolts (the most restricted first). Tighten all bolts evenly starting from the center and alternate from side to side.
6. Replace the clutch linkage, oil filter, dipstick tube, alternator, and spark plugs. On late model cars with power steering, use the spacer provided in the accessory package and the long bolt from the stock exhaust manifold to remount the power steering. See Fig. A.

NOTE:

- A) Early models will require conversion screw-on type oil filter.
- B) Modify the clutch linkage as shown in Fig. B.
- C) Models with generator/alternator on the left side must purchase Hooker bracket P/N (10928HKR). See Fig. C.
- D) If the header is equipped with bushings for smog injection tubes, the bracket must be notched to clear the bushings. See Fig D.

RIGHT SIDE

1. Remove the spark plugs, stock exhaust manifold, and starter. On cars equipped with air conditioning, unbolt the compressor and lay aside. Some year models may not require starter removal.

NOTE: Some models may require the floor board heat shield removal for adequate header clearance.

2. Starting from below, work the header up through the chassis into position. Some year models may require the engine to be raised straight slightly (use a board between the pan and jack).
3. Place the gasket into position and start all the bolts (most restricted first). Tighten all bolts evenly starting from the center and alternate from side to side.
4. Replace the starter and connect the wires. Re-route the wires as needed for clearance.
5. Tighten all bolts evenly and replace the spark plugs.

6. To connect the collector to your stock exhaust system, purchase the Hooker reducer kit P/N 11030HKR. Position the gasket and the bolt the reducer to the collector. Cut the head pipe to the correct length and weld the reducer.
7. Connect the battery, start the engine, and check for leaks. Be sure that all brake lines, fuel lines, and electrical wires have sufficient clearance. Reroute, as necessary.
8. When finished, give your car a test drive, checking carefully for any new noises. After several days of driving, retighten all the bolts.

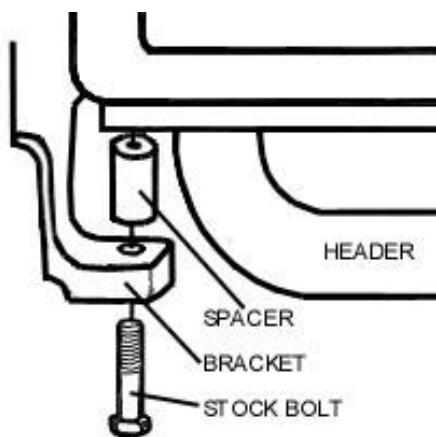

Figure A

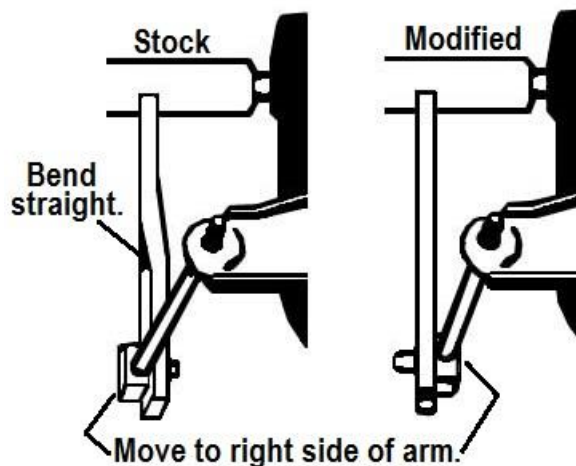

Figure B: Clutch Linkage Modification

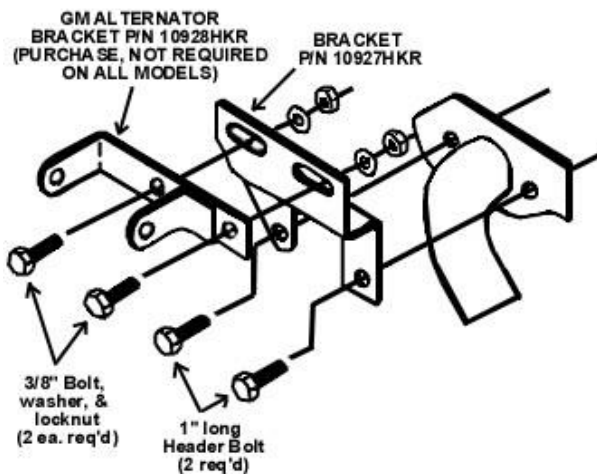

Figure C

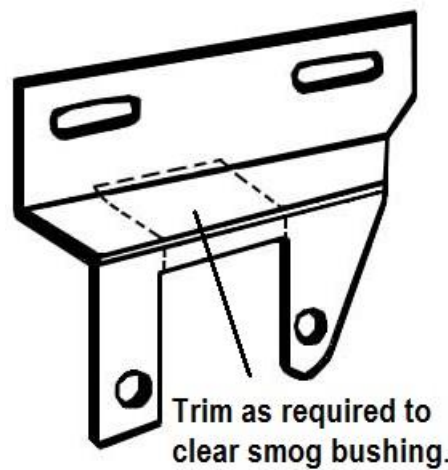

Figure D

LIMITATION OF LIABILITY – DISCLAIMER

The regulation of emissions production, noise levels, and safety standards is undertaken by the federal government, each of the fifty state legislatures, and by many local municipalities, towns, and counties. HOOKER Industries makes no warranties of merchantability, of fitness for particular purpose, or that its products are approved for general use, or that its products comply with laws, regulations, or ordinances in the states where they may be sold to the ultimate purchaser, the consumer.

Unless expressly stated to the contrary in the catalog, instruction sheet, or price list, the entire risk as to the conformity of any company product in any such state and as to repair should the product prove to be defective or nonconforming, is on the retail purchaser, the buyer, the ultimate consumer, of such product and it is not upon the seller, distributor, or manufacturer. In this connection, the retail purchaser, the buyer, the ultimate consumer assumes the burden of the entire cost of any and all necessary service, alterations, or repair.

The foregoing statement limits the liability of the manufacturer.

California vehicle code, sections 27156 and 38391, prohibits the advertising, offering for sale, or installation of any device, which modifies a vehicle's emission control system, unless exempted, unless otherwise noted. HOOKER™ Headers that have not received an Executive Order (E.O.) exemption from these code sections are not legal for sale or use in California on vehicles originally equipped with catalytic converters, except for racing vehicles, which may never be driven upon a highway. Check with your local authorities to determine if these headers are legal for use in your particular area.

Hooker Technical Support
Toll-Free Phone: 1-866-464-6553
Phone: 1-270-781-9741

For online help, please refer to the Tech Service section of our website: www.holley.com