



***StealthRam™ Small Block Chevy
Power Pack Systems
Standard and Vortec Intake Versions***



550-707 (Early/Late Heads)
550-708 (Early/Late Heads) Polished
550-710 (Vortec Heads) Polished



**HARDWARE AND FUEL SYSTEM
INSTALLATION MANUAL
P/N 199R10580**

NOTE: These instructions must be read and fully understood before beginning installation. If this manual is not fully understood, installation should not be attempted. Failure to follow these instructions, including the pictures, may result in subsequent system failure.

TABLE OF CONTENTS:

1.0 INTRODUCTION.....	2
2.0 BEFORE YOU BEGIN.....	3
3.0 WARNINGS, NOTES, AND NOTICES.....	3
4.0 SKILL LEVEL REQUIRED.....	3
5.0 ADDITIONAL ITEMS REQUIRED FOR INSTALLATION.....	3
6.0 TOOLS REQUIRED FOR INSTALLATION.....	4
7.0 PLANNING THE INSTALLATION.....	4
8.0 REMOVAL OF EXISTING FUEL SYSTEM.....	4
8.1 Preparing the Manifold for Installation.....	4
8.2A Installation of the STEALTHRAM™ Manifold (Standard Manifold).....	5
8.2B Installation of the STEALTHRAM™ Manifold (Vortec Manifold).....	5
8.2C CONTINUE HERE AFTER COMPLETING SECTION 8.2A OR 8.2B.....	5
8.3 Installing the Distributor.....	7
8.4 Vacuum Line Connections.....	8
9.0 SUPPLY AND RETURN FUEL SYSTEM INSTALLATION.....	8
9.1 Fuel Supply/Return System Description.....	8
9.2 Fuel Pressure Regulator.....	9
9.3 Fuel Pump Installation.....	9
9.4 Fuel Line Mounting.....	10
9.5 Fuel Filters.....	10
9.6 Return Line Installation.....	10
9.7 Oxygen Sensor Installation.....	11
9.7.1 Oxygen Sensor Mounting Procedure (not included).....	11
10.0 SENSOR WIRING.....	12
11.0 MECHANICAL CHECKOUT BEFORE STARTING ENGINE.....	13
APPENDIX 1 ENGINE APPLICATION AND SELECTION OF FUEL MANAGEMENT SYSTEM COMPONENTS.....	14

1.0 INTRODUCTION

Congratulations on your purchase of the **STEALTHRAM™** multi-point power pack kit! Holley has written this manual for the installation of the **STEALTHRAM™** manifold and fuel system. Please read all the **WARNINGS, NOTES, and TIPS**, as they contain valuable information that can save you time and money. For information or parts assistance, please contact technical service at 1-270-781-9741, M-F, 8-5 CST. Have the part number of the product you purchased ready when you call.

NOTE: These kits require the use of a small diameter distributor, such as a small cap GM HEI or most MSD distributors. A large cap GM HEI will not fit with these kits.

WARNING! The **STEALTHRAM™** system consists of a number of sophisticated components. Failure of any one component does not constitute, nor does it justify, warranty of the complete system. Individual service items are available for replacement of components. If assistance is required or if you need further warranty clarification, you can call Holley Technical Service at the number shown above.

WARNING! To preserve warranty, these instructions must be read and followed thoroughly and completely before and during installation. It is important that you become familiar with the parts and the installation of the **STEALTHRAM™** system, before you begin. Failure to read and understand these instructions could result in damage to **STEALTHRAM™** components that is not covered by the warranty and could result in serious personal injury and property damage.

WARNING! Failure to follow all of the above will result in an improper installation, which may lead to personal injury, including death, and/or property damage. Improper installation and/or misuse of this or any Holley product will void all warranties.

WARNING! Use of some RTV silicone sealers will destroy the oxygen sensor used with this product. Ensure that the RTV silicone sealant you use is compatible with oxygen sensor vehicles. This information should be found on the RTV package.

2.0 BEFORE YOU BEGIN

Fuel injection systems have proven to increase engine performance by allowing the engine to operate to the best output it is capable of producing. Make sure your engine is in good basic running order before installing the **STEALTHRAM™** power pack system.

Anything that increases the power of your engine demands more from all the components and systems. If your engine is in poor condition before you begin this installation, you won't get the results you want.

Fuel injection is more efficient, but also less forgiving than a carburetor. A properly tuned EFI system can disclose hidden problems your carburetor may have concealed. Corroded terminals or a weak battery, alternator, or ignition system will not adversely affect your carburetor, but they will interfere with the precision functions of an EFI system.

The engine cooling system must have a working 140°F to 210°F thermostat.

3.0 WARNINGS, NOTES, AND NOTICES

WARNING! For the safety and protection of you and others, only a trained mechanic that has adequate fuel system experience must perform the installation, adjustment, and repair. It is particularly important to remember one of the very basic principles of safety: fuel vapors are heavier than air and tend to collect in low places where an explosive fuel/air mixture may be ignited by any spark or flame resulting in property damage, personal injury and/or death. Extreme caution must be exercised to prevent spillage and thus eliminate the formation of such fuel vapors.

WARNING! These instructions are provided as a general guideline for installation. You must use your own judgment to determine whether the engine's, or your safety will be endangered by any procedure selected. You should consult factory engine manuals to ensure compliance with fastener torque and other important specifications unique to each engine.

WARNING! This type of work **MUST** be performed in a well-ventilated area. Do not smoke or have an open flame present near gasoline vapors or an explosion may result.

4.0 SKILL LEVEL REQUIRED

Installation of the **STEALTHRAM™** intake system and the ECU requires approximately the same level of skill and experience to replace or service an induction system consisting of a carburetor and conventional intake manifold (as well as basic wiring skills for the installations of the ECU).

Adequate skills for modifying the vehicle fuel supply are critical, and will vary widely, depending upon the selected components and methods of fuel line plumbing. The most basic level will require the user to plumb a high-pressure supply fuel line and a tank-return fuel line to the fuel rails. The most complex level may require the user to modify the fuel tank, re-route or add fuel lines, or mount various combinations of electrical and/or mechanical fuel pumps. Some fabrications may be required, depending on applications, for throttle cable assemblies, throttle cable bracket, and thermostat housings.

NOTICE: If you are not absolutely certain that you have the skills and experience required to perform these procedures, we strongly recommend you have this system installed and tested by a technician with specialized training in EFI and fuel systems service.

5.0 ADDITIONAL ITEMS REQUIRED FOR INSTALLATION

The following is a list of materials that are needed, depending on the application.

- Fuel Injectors (See Appendix 1 for proper selection)
- 3/8" fuel hose (must meet SAE J30)
- 3/8" steel fuel line (must meet SAE J526)
- Assorted vacuum plugs
- Various Electrical Connectors
- TPI throttle and trans cables and bracket
- Intake gaskets (FelPro #1205 for std heads & Vortec gaskets for Vortec systems)
- Fuel Pump
- PTFE pipe sealing compound
- Heat shrink
- RTV sealant (O₂ sensor compatible)
- Intake bolts for std intake or Vortec intake
- EFI Operating System

6.0 TOOLS REQUIRED FOR INSTALLATION

The following is a list of materials that are needed, depending on the application.

- Standard wrench set
- Medium blade screwdriver
- Drill and assorted bit sizes
- #2 Phillips screwdriver
- Allen wrench set
- Gasket scraper
- Hole saw (2")
- 10" adjustable wrench
- Torque wrench
- Timing/advance light

7.0 PLANNING THE INSTALLATION

Before starting the installation of the **STEALTHRAM™** system, several things must be decided.

- Mounting location of the fuel pump & fuel filters
- Routing of the fuel supply line from the tank, to the filter, to the pump
- Routing of the high-pressure fuel supply line from the pump to 10micron fuel filter to the fuel rails on top of the manifold
- Routing of the fuel return line from the pressure regulator to the fuel tank
- Proper throttle cable installation
- Proper thermostat housing clearance

8.0 REMOVAL OF EXISTING FUEL SYSTEM

1. Disconnect the ground side of the battery.
2. Drain the cooling system. Remove the cooling system hoses and thermostat housing.

DANGER! FAILURE TO RELEASE FUEL PRESSURE COULD RESULT IN UNINTENTIONAL FUEL SPRAY, WHICH COULD CAUSE A FIRE HAZARD OR SERIOUS PERSONAL INJURY.

DANGER! BEFORE DISCONNECTING OR REMOVING FUEL LINES, MAKE SURE THE ENGINE IS COLD. DO NOT SMOKE. EXTINGUISH ALL OPEN FLAMES. AN OPEN FLAME, SPARK, OR EXTREME HEAT NEAR GASOLINE COULD RESULT IN A FIRE AND/OR EXPLOSION CAUSING SERIOUS INJURY OR DEATH!

3. Drain the fuel tank. Disconnect the fuel supply line or disconnect the fuel supply line and plug the hose. Disconnect all throttle linkages.
4. Identify or number the ignition wires. Numbering the ignition wires will help in reconnecting them during MPFI system assembly. Remove the ignition wires from the coil and spark plugs.
5. Remove the ignition cables and distributor cap as one unit.
6. Note the position of the rotor and the distributor housing. Mark the rotor position on the distributor and mark the distributor housing position on the engine block to ensure accurate re-assembly. After marking the position of the rotor and distributor, remove the distributor. It is easiest if the rotor points directly towards the firewall.
7. Loosen all the manifold bolts before removal. Remove the manifold bolts.

DANGER! FROM THIS POINT FORWARD, USE EXTRA CAUTION TO ENSURE THAT NO GASKET MATERIAL OR OTHER FOREIGN MATTER ENTERS THE OIL PASSAGES, HEAD PORTS, OR ANY OTHER LOCATION WHERE AN OBSTRUCTION MIGHT CAUSE DAMAGE.

8. Remove the existing manifold. If required, remove the valve covers. Remove the mechanical fuel pump and push rod. Install the mechanical fuel pump block-off plate (included).

8.1 Preparing the Manifold for Installation

1. Protect the lifter galley with clean shop rags. Close off the ports by stuffing them with clean shop rags.

WARNING! Failure to cover the intake opening with a clean towel could result in dirt or debris entering the engine. Dirt or debris in the induction system can cause engine damage, which may require a complete engine overhaul.

2. Using a gasket scraper, remove the gasket material from the heads and block. When all loose material is removed, carefully remove the shop rags from the ports, ensuring that no material falls into the passages. Using a shop vac, remove all debris from the lifter gallery.
3. Inspect carefully. Use a flashlight to inspect the interior of all air, oil, and water passages.

4. Soak a clean shop rag with solvent, and clean all sealing surfaces. Surfaces must be completely clean to ensure a reliable seal between the components and gaskets.

8.2A Installation of the STEALTHRAM™ Manifold (Standard Manifold)

WARNING! USE THIS SECTION ONLY IF USING A STANDARD MANIFOLD! Skip to Section 8.2B if you have a Vortec manifold.

WARNING! Use new gaskets. Be sure you are using the proper gasket for your engine for aluminum manifolds.

1. The manifold comes with the rails, fittings, and crossover loosely installed in the proper locations. The crossover line will have to be removed in order to install the intake manifold bolts. The injectors, fittings, rails, and crossover should be assembled and tightened after the manifold is installed on the engine.
2. Install the manifold gaskets, carefully following the instructions provided by the gasket manufacturer.
3. Use O₂ sensor-compatible RTV (again following the manufacturer's instructions) around all water passages and for end seals, if the end seal gaskets are not used.
4. Carefully position the manifold on the heads, so the bolt holes in the manifold are centered over the bolt holes in the heads.
5. Handstart all the bolts.
6. Torque down the manifold bolts in the sequence in Fig. 1a and torque in gradual steps to 30 ft./lbs. Re-torque after the engine has been run.

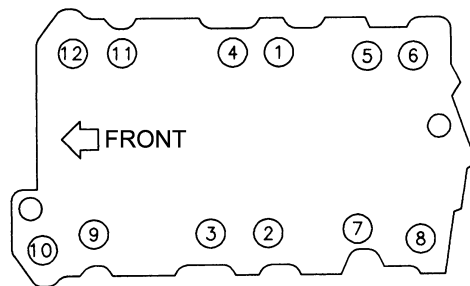

MANIFOLD TIGHTENING SEQUENCE

Figure 1a

8.2B Installation of the STEALTHRAM™ Manifold (Vortec Manifold)

WARNING! USE THIS SECTION ONLY IF USING A VORTEC MANIFOLD! Go back to Section 8.2A if you have a standard manifold.

WARNING! Use new gaskets.

NOTE: If the engine is a 1996 or later Gen 1 GM block, you must install a coolant bypass line from the intake manifold to the water pump. The bypass should run to the passenger's side outlet on the water pump using a 5/8" hose.

1. The manifold comes with the rails, fittings, and crossover loosely installed in the proper locations. The crossover line will have to be removed in order to install the intake manifold bolts. The injectors, fittings, rails, and crossover should be assembled and tightened after the manifold is installed on the engine.
2. Install the manifold gaskets, carefully following the instructions provided by the gasket manufacturer.
3. Use O₂ sensor-compatible RTV (again following the manufacturer's instructions) to lay a 1/4" bead or RTV on the engine block china walls that overlaps the intake gasket at the 4 corners.
4. Carefully position the manifold on the heads, so the bolt holes in the manifold are centered over the bolt holes in the heads.
5. Apply 242 (Blue) Loctite™ to the intake bolt threads. The intake bolts should be a 1/4-20 x 1-1/2" fastener.
6. Handstart all the bolts.
7. It is very important that the intake manifold is torqued properly or damage to the gasket will occur. Tighten all eight bolts, in the sequence shown in Figure 1b to 30 inch/pounds. Then tighten to 60 inch/pounds. Finally tighten to 132 inch/pounds (132 inch/pounds = 11 foot/pounds).

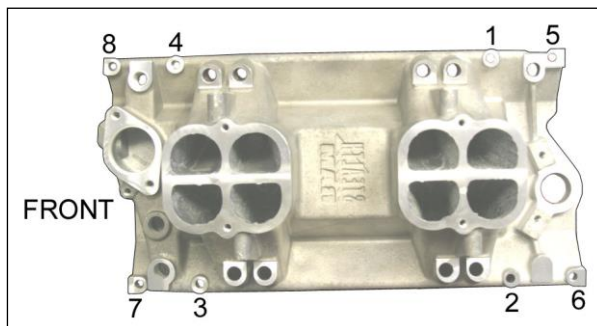

Figure 1b

8.2C CONTINUE HERE AFTER COMPLETING SECTION 8.2A OR 8.2B.

1. Remove the fuel rails. The fuel injectors are contained in a separate package in Avenger kits. Injectors need to be purchased separately. Lubricate the fuel injector top and bottom O-rings with an O-ring lubricant or motor oil and place the injectors in the fuel rails. Do not use synthetic, animal, or vegetable oils. Be care not to damage the O-rings.

NOTE: HP Systems DO NOT include injectors. For injector recommendations, please see Appendix 1.

WARNING! Damage of the O-ring can cause fuel leakage. A fuel leak may result in a fire or an explosion hazard, which could cause serious injury or death.

2. Carefully install the injectors into the rails and then install the injectors and both rails into the manifold. Reinstall the four 1/4-20 x 1" Allen head screws that held the rails in place and tighten securely.
3. The rear driver's side fuel rail should have a -6/-6AN fitting already installed. The rear passenger side fuel rail should have a -6 plug installed. See Figure 2. Make sure these fittings are tight.

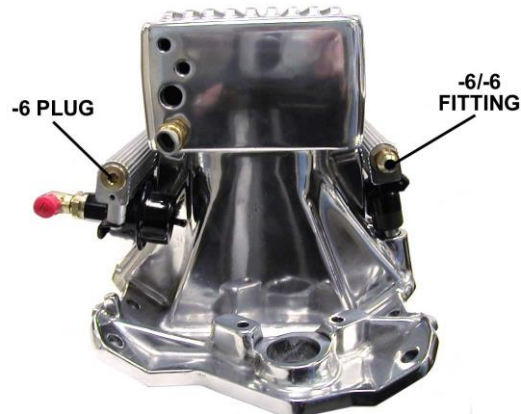

Figure 2

4. The front of each rail should have 90 degree fittings. Do not tighten them yet. Reattach the front crossover tube. Tighten completely hand tight.
5. After the front crossover tube is installed hand tight, tighten the nut on the two front 90 degree fittings.
6. Securely tighten the front crossover tube with a wrench. See Figure 3.

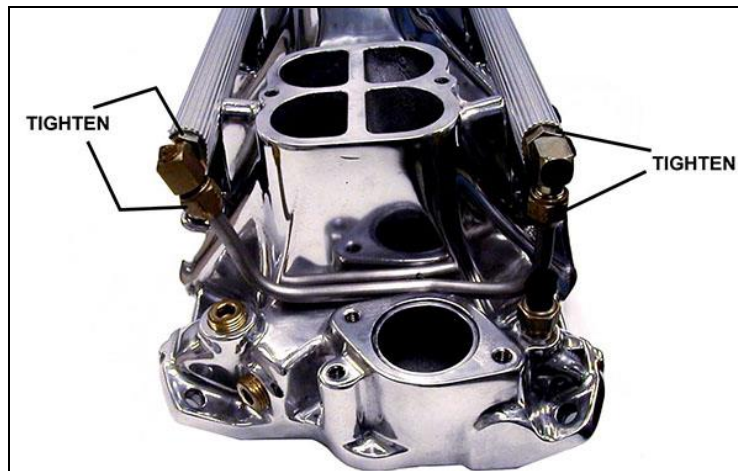

Figure 3

7. The regulator should already be installed. Make sure that the two Allen head screws securing it to the fuel rail are tight. Also, check that the regulator fitting is tight and is pointed in the desired direction. Do not overtighten the fitting in the regulator or it will leak.
8. The upper manifold will be installed next. There is a 3/8-18 NPT hole on the underside of the upper manifold that needs to be plugged if it is not used. Do this before the manifold is installed. There is a plug included. There are two 3/8-18 NPT and two 1/8-27 NPT holes in the rear of the manifold. The two 1/8-27 NPT should be used for the MAP sensor and the fuel pressure regulator reference hose. Barbed fittings are included for this. The one 3/8-18 NPT fitting is used for the manifold air temperature sensor (gray/white connector). The other 3/8-18 NPT hole can be used for power brakes and other accessories. There is a 3/8-18 NPT plug included, if this hole is not needed. These fittings can be installed now or later.
9. Install the upper manifold with the gaskets provided. It is advised to use a light amount of adhesive or sealant on the gaskets. Install the four stainless 5/16-18x4 socket head cap screws. Torque to 18-20 ft./lbs.

10. The Idle Air Control motor (IAC) will be installed on the throttle body next. Use the M4 x .7 x 20mm SS Allen head screws and washers provided. Use the provided gasket. Tighten the adapter securely. See Figure 4.

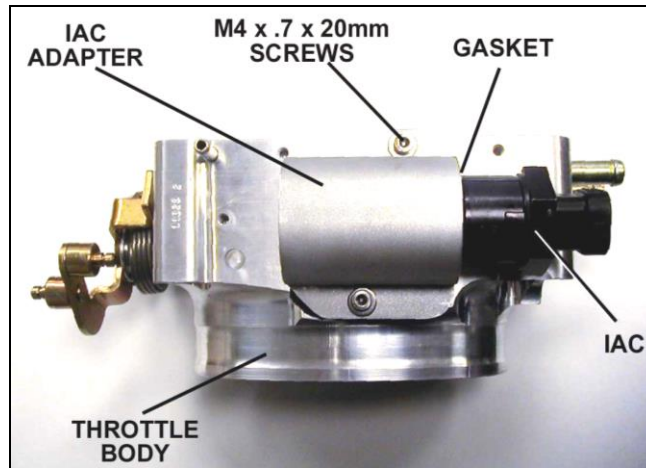

Figure 4

11. Next, install the throttle body. Use the supplied hardware and gasket that comes with the throttle body.
12. Install the coolant temperature sensor (black connector) into a coolant passage. The driver's side front of the intake is an ideal spot. Use PTFE tape or sealer on it.
13. Install the new thermostat housing gasket. Replace the thermostat housing. Replace the coolant hoses. Refill the cooling system.
14. The throttle linkage can be attached next. The **STEALTHRAM™** system uses a TPI-style throttle body. Brackets and cables for a TPI engine should be used. The following specify P/Ns, if new ones are needed.

Throttle Cable Mounting Bracket	<u>Lokar</u>	<u>GM</u>
	TCB-40TP1	14083307
	TCB-40TP2	
	TCB-40TP3	
	TCB-40SP	

Throttle Cable	TC-1000TP	14080202
-----------------------	-----------	----------

GM and Lokar can also supply transmission cables.

15. Mount the MAP sensor. It can be mounted on the firewall near the back of the intake manifold. Do not mount it so that the vacuum line is facing up. The sensor should be mounted so that condensation cannot enter the sensor. This would damage the sensor or cause engine performance problems.
16. Mount the TPS sensor. Use the supplied M4.5 screws with lockwashers. See Figure 5.



Figure 5

8.3 Installing the Distributor

Follow the manufacturer's recommended procedures for the following steps:

1. Drop in the distributor, making sure that the rotor aligns with the marks made during disassembly. If you are installing a new distributor, you will have to make sure it is properly timed.
2. Align the distributor housing with the marks made on the block during disassembly.
3. Ensure the distributor seats properly against the manifold.
4. Ensure the distributor shaft is fully engaged in the oil pump.
5. Bolt the distributor hold-down clamp to the manifold.
6. Replace the distributor cap.
7. Replace the spark plug wires and check that they are in the correct firing order.

8.4 Vacuum Line Connections

1. Vacuum line needs to be run from the back of the manifold to the MAP sensor and to the fuel pressure regulator. See Figure 6. The MAP sensor should be mounted such that it is above the vacuum connection in the intake so that condensation does not run into the sensor. The map sensor vacuum inlet should be pointed at a downward angle or at worst horizontal as it would be if it were mounted to the firewall.
2. There is a vacuum port on the bottom of the throttle body. It can be used or plugged.
3. The throttle body has two large fittings on the side. The top is for the PCV inlet air, if needed. The lower can be connected to a PCV valve.

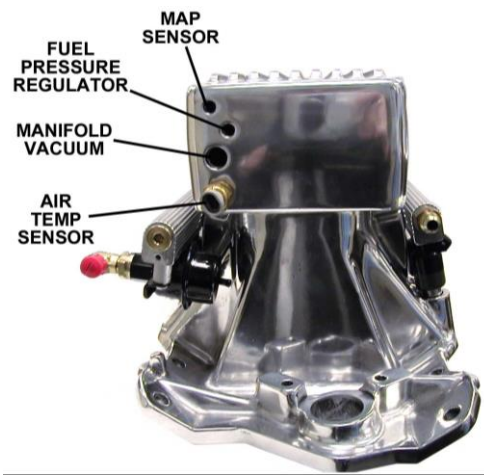

Figure 6

9.0 SUPPLY AND RETURN FUEL SYSTEM INSTALLATION

NOTE: Power Pack systems DO NOT include a fuel pump. The installer can select their own in-tank or in-line pump of choice. Holley offers in-line and in-tank EFI fuel pumps. P/N 12-920 is an in-line pump rated for up to 600-650 HP naturally aspirated engines. It is the recommended in-line pump for Holley Multiport EFI systems for engines under 650 HP. Make sure the fuel pump flow is sufficient to support for the injector size selected.

9.1 Fuel Supply/Return System Description

The high-pressure fuel supply system consists of the following sub-systems: the fuel pick-up, the coarse fuel pump pre-filter, the high-pressure electric fuel pump, the 10micron high pressure fuel filter, and the feed line (See Figure 3). The fuel pick-up delivers fuel from the tank to the inlet of the fuel pump pre-filter. From the filter, the fuel line supplies filtered fuel to the high-pressure pump inlet. The high-pressure electric fuel pump delivers pressurized fuel to the 10micron fuel filter, which in turn delivers filtered pressurized fuel to the fuel rails, fuel injectors, and the fuel pressure regulator. The function of the regulator is to maintain a constant fuel pressure of 300kPa (43.5psi). The outlet of the regulator returns the excess fuel back to the fuel tank.

The following section covers the installation of an in-line pump such as Holley PN 12-920. If AN lines and fittings are used, obtain AN style filters. AN fittings are available for the 12-920 pump. PN 26-160 contains two -6 pump fittings and PN 26-180 contains two -8 pump fittings.

All of the fittings on the intake manifold are -6 AN fittings (except the internal threads of the fuel pressure regulator which have a "Saginaw" thread. There are barbed adapters included that can be installed on the inlet and return fittings that can be used to connect to high pressure rated rubber fuel hose.

9.2 Fuel Pressure Regulator

The function of the fuel pressure regulator is to provide constant fuel pressure for the fuel injectors. Constant fuel pressure is essential to ensure an accurate fuel metering process. The fuel pressure regulator of the system is set to 300kPa (43.5 psi) to match the flow characteristics of the fuel injectors. The pressure regulator is referenced to the manifold pressure to ensure the required differential pressure for the metering event. Thus, at high manifold vacuum (i.e. idle) the fuel pressure gauge will read a fuel pressure that is slightly lower than 300kPa (43.5 psi) because the gauge is referenced to atmospheric conditions and not to the intake conditions. The pressure reading at idle will vary with the application as manifold vacuum changes from engine to engine and from application to application. The fuel pressure regulator included is adjustable. To adjust the fuel pressure: remove the vacuum reference line and turn the screw clockwise to increase the pressure (or counter-clockwise to decrease the fuel). Fuel pressure can be lowered slightly or raised to reduce or increase the amount of fuel the injectors add. This is usually only done when the injectors used need to have their flow decreased at idle or increased at wide-open throttle. Make sure you input the actual pressure into the software in the "Engine Parameters" section.

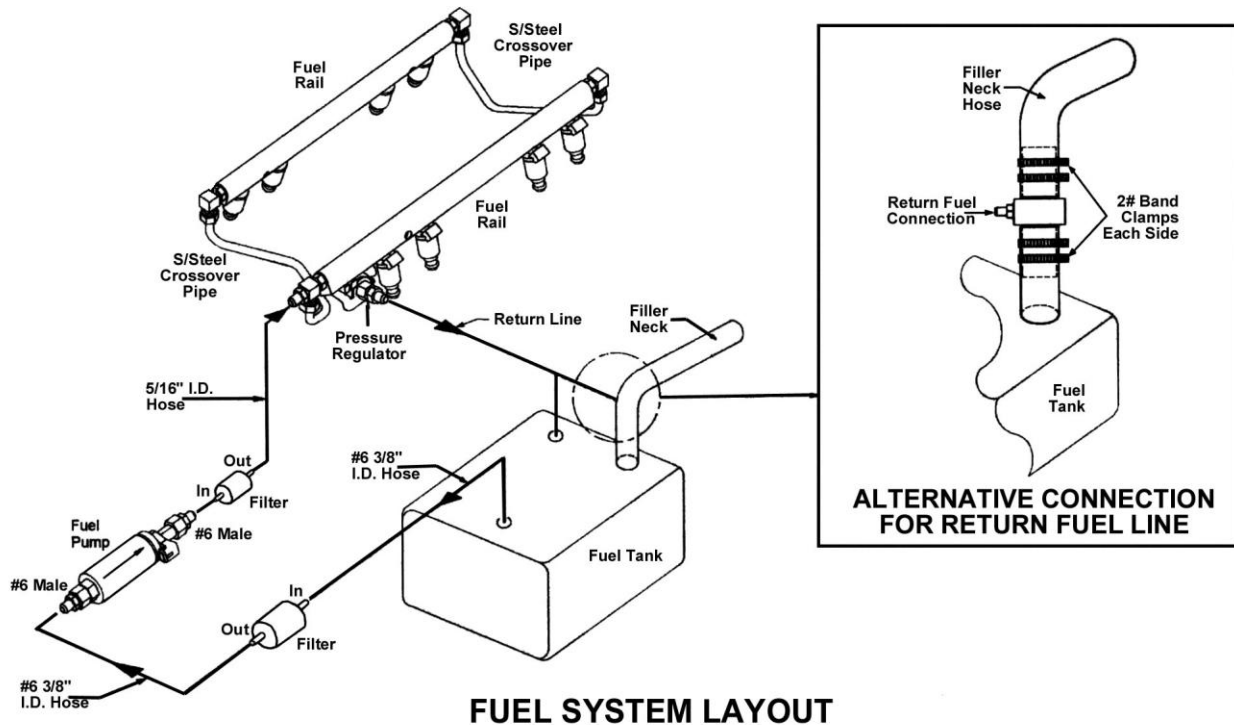

Figure 7

9.3 Fuel Pump Installation

DANGER! NEVER GET UNDER A VEHICLE SUPPORTED ONLY BY A JACK. SERIOUS INJURY OR DEATH CAN RESULT FROM VEHICLES FALLING OFF OF JACKS. BEFORE WORKING UNDERNEATH A VEHICLE, SUPPORT SOLIDLY WITH JACK STANDS.

Most high-pressure fuel pumps have limited suction characteristics, so they need to be mounted as low as possible and should be mounted no higher than the bottom of the fuel tank. The pump can be mounted either horizontally or vertically. When mounting the fuel pump, check to make sure that you have the fuel flow in the correct direction. This may sound like a foolish reminder, but it is a common installation error. To prevent damage to the fuel pump before the fuel system is filled with fuel, drip/spray some light lubricant (such as 10w-30 motor oil) into the inlet side of the pump.

1. Make sure fuel tank is properly vented.
2. Mount the electric fuel pump as close to the fuel tank outlet as possible with the bracket provided. Mounting the fuel pump in this manner will ensure that the pump will prime easily and purge fuel vapors in the fuel lines to ensure faster starts.

DANGER! TAKE PRECAUTIONS TO ENSURE THAT ALL FUEL LINE ROUTINGS ARE AWAY FROM HEAT SOURCES, SUCH AS THE ENGINE, CATALYTIC CONVERTER, OR EXHAUST PIPES. A FIRE OR EXPLOSION HAZARD COULD CAUSE SERIOUS INJURY OR DEATH.

DANGER! ENSURE THAT THE FUEL PUMP MOUNTING LOCATION WILL NOT INTERFERE WITH ANY UNDER-THE-VEHICLE COMPONENTS, ESPECIALLY AT THE EXTREME LIMITS OF THE SUSPENSION TRAVEL. A FIRE OR EXPLOSION HAZARD COULD CAUSE SERIOUS INJURY OR DEATH.

3. Connect the pump to the tank using 3/8" I.D. fuel hose and fuel line. Connect the outlet of the pump to the steel line, which runs to the front of the vehicle with 3/8" I.D. fuel hose, depending on the diameter of the steel fuel line. All fuel hose used must meet SAE J30 performance standards. See fuel filters information below.

9.4 Fuel Line Mounting

DANGER! FAILURE TO USE A FUEL HOSE THAT MEETS SAE J30 STANDARDS COULD RESULT IN FUEL LEAKS. A FUEL LEAK MAY RESULT IN A FIRE OR EXPLOSION HAZARD, WHICH COULD CAUSE SERIOUS INJURY OR DEATH.

1. If using the existing fuel lines, inspect and replace any hose, clamp, or fuel line showing any sign of aging or not meeting SAE J30 fuel hose specifications. If you are not using the existing fuel lines, you will need a fuel line routed to and from the engine compartment and fuel rails. Use a 3/8" steel fuel line available at any auto parts store. Any steel fuel line must meet SAE J526 standards. Any time a rubber hose is connected to a steel fuel line, the steel fuel line must have a "barb" or "nipple" on it to properly retain the hose (along with hose clamps). Either use the proper tool to put a "nipple" on the end of the tube (similar to the ends of the fuel filters), or use a compression fitting and a barded fitting adapter that is the proper size for the lines used. Clamping a rubber hose to a steel line that has the end squarely cut off does not ensure a safe connection. The inlet to the fuel rail is a -6 male fitting. A -6 female fitting can be used to connect to it. A 3/8" barbed fitting is included that connects to the -6 male that allows the connection of a rubber fuel hose that meets J30 performance standards.

DANGER! FAILURE TO USE A STEEL FUEL LINE THAT MEETS SAE J526 STANDARDS COULD RESULT IN FUEL LEAKS. A FUEL LEAK MAY RESULT IN A FIRE OR EXPLOSION HAZARD, WHICH COULD CAUSE SERIOUS INJURY OR DEATH.

DANGER! TAKE PRECAUTIONS TO ENSURE THAT ALL FUEL LINE ROUTINGS ARE AWAY FROM HEAT SOURCES, SUCH AS THE ENGINE, CATALYTIC CONVERTER, OR EXHAUST PIPES. A FIRE OR EXPLOSION HAZARD COULD CAUSE SERIOUS INJURY OR DEATH.

DANGER! RIGID FUEL LINE TUBING SHOULD BE USED FOR UNDER VEHICLE RUNS, SUCH AS A LONG VEHICLE FRAME RAILS OR UNDER FLOOR PANS. FAILURE TO DO SO IS A POTENTIAL FIRE OR EXPLOSION HAZARD, WHICH COULD CAUSE SERIOUS INJURY OR DEATH.

2. Anchor all fuel lines securely to solid chassis members at 1 ½ foot intervals, using rubber coated steel clamps. Use of only approved steel fuel line tubing will afford maximum fuel line protection against road hazards, gravel bombardment, and premature wearing due to flexing, temperature extremes, road salt, weather, etc.

9.5 Fuel Filters

WARNING! It is very important the fuel filters have the proper flow capacity, burst pressure rating, and filter size. The flow capacity of the filters must be at least 60 gallons per hour (gph), and the filter size must be no bigger than 10 microns for the high fuel pressure filter and not bigger than 75 microns for the fuel pump inlet filter. The high-pressure fuel filter should be rated for at least 150 psi burst pressure.

DANGER! FAILURE TO USE A HIGH-PRESSURE FUEL FILTER LINE RATED FOR A MINIMUM OF 100 PSI BURST PRESSURE COULD RESULT IN FUEL LEAKS OR BURSTING OF THE FUEL FILTER. A FUEL LEAK MAY RESULT IN A FIRE OR EXPLOSION HAZARD, WHICH COULD CAUSE SERIOUS INJURY OR DEATH.

The fuel pump inlet filter must be plumbed between the fuel tank and the fuel pump. It should be mounted as close to the fuel tank as possible and should be mounted no higher than the top of the fuel tank. The high-pressure fuel filter should be plumbed between the fuel pump and the fuel rail. It should be mounted as close to the fuel rail as possible, but should not be mounted above the fuel rail level.

Be careful to ensure that the suction part of the fuel system contains no air leaks. Air leaks are caused by holes and/or crevices so small that they will not leak fuel. Just because fuel is not leaking out, does not mean air is not leaking in. Common causes of air leaks are not using thread-sealing compound on fittings and cracks or holes in fuel lines. Air leaks could potentially cause fuel pump failure and or inadequate fuel supply to the fuel rails.

9.6 Return Line Installation

DANGER! DO NOT USE THE VAPOR CANISTER LINES AS A FUEL RETURN LINE. POSSIBLE FUEL LEAKS MAY CREATE A FIRE OR EXPLOSION HAZARD, CAUSING SERIOUS INJURY OR DEATH.

WARNING! Use only an approved steel fuel line. The return fuel line should enter the fuel tank at the "fuel level sending unit flange" or at the "filler neck". The connection should be made below the flapper valve of the filler neck. The filler neck or sending unit must be removed from the tank to perform this operation.

DANGER! PROPER INSTALLATION OF THE FUEL RETURN LINE MAY REQUIRE THE COMPLETE REMOVAL OF THE FUEL TANK. THIS WORK SHOULD BE DONE BY A FUEL TANK SPECIALIST, WHO REGULARLY DOES THIS WORK AND IS FAMILIAR WITH SAFETY REGULATIONS AND PRECAUTIONS NECESSARY TO DO THIS WORK. IF A PERSON ATTEMPTS THIS WORK WHO IS NOT FAMILIAR WITH THE SAFETY REGULATIONS AND PRECAUTIONS, AN EXPLOSIVE HAZARD MAY RESULT, CAUSING SERIOUS INJURY OR DEATH.

The fuel return line from the fuel pressure regulator must go back to the fuel tank and enter the fuel tank with a fitting that has an internal diameter of at least 3/8".

The fitting on the regulator is a -6 male fitting. A -6 female fitting can be connected to it. A 3/8" barbed fitting is included that attaches to the regulator to allow for rubber fuel hose to be connected to it that meets J30 performance standards.

The internal thread on the fuel pressure regulator is a "Saginaw" style thread and is internally sealed with an O-ring. This fitting should not be over-tightened in the regulator or it will leak.

Returning fuel should be routed back to the tank away from the fuel tank pick-up tube. This will allow air bubbles from the returned fuel to dissipate, before they are drawn into the pick-up tube.

There are several options, including the following, which meet the above criteria for returning the fuel to the fuel tank.

- Use a fitting already in the fuel tank.
- Use the vent fitting. Be very careful not to block the fuel vapor from escaping the tank.
- Route the return line into the filler neck. This can be done by cutting the filler neck, inserting a welded "T" fitting, and securing the neck with multiple clamps.
- Drill and weld a new fitting into the tank.

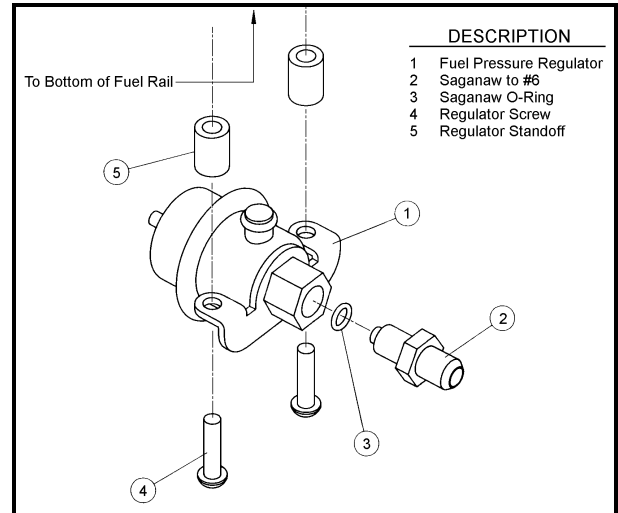

Figure 8

NOTICE: For the best performance of your fuel supply system, an in-tank pump is recommended. Such an installation can be achieved by either buying a late model fuel tank or have your tank modified by a professional company that installs an in-tank pump with the required swirl pods and baffles.

DANGER! MODIFICATIONS TO FUEL TANKS SHOULD BE DONE BY A FUEL TANK SPECIALIST, WHO REGULARLY DOES THIS WORK AND IS FAMILIAR WITH THE SAFETY REGULATIONS AND PRECAUTIONS NECESSARY TO DO THIS WORK. IF A PERSON ATTEMPTS THIS WORK WHO IS NOT FAMILIAR WITH THE SAFETY REGULATIONS AND PRECAUTIONS, AN EXPLOSIVE HAZARD MAY RESULT, CAUSING SERIOUS INJURY OR DEATH.

9.7 Oxygen Sensor Installation

9.7.1 Oxygen Sensor Mounting Procedure (not included)

NOTE: Someone should install the oxygen sensor boss that has experience welding exhaust systems. Any competent exhaust shop is able to perform this task at a minimal cost.

WARNING! Use of leaded fuels will degrade the oxygen sensor over time and will result in incorrect exhaust gas oxygen-content readings.

WARNING! Use of some RTV silicone sealers will destroy the oxygen sensor used with this product. Ensure that the RTV silicone sealant you use is compatible with oxygen sensor vehicles. This information should be found on the RTV package.

1. Locate a position for the oxygen sensor as close to the engine as possible. If your vehicle has catalytic converters, the oxygen sensor **MUST** be located between the engine and the catalytic converters. Good locations are in the drop pipe, or in the "Y" pipe on single exhaust systems. Pick a location that allows easy installation of the oxygen sensor, but will protect the sensor from road hazards.

NOTE: Vehicles with open exhaust systems will require at least 18-20" of pipe after the sensor to eliminate false readings resulting from atmospheric reversion. Even then, a false lean reading may occur at idle.

2. Drill a 7/8" hole in the location picked for the sensor. Weld the threaded boss into the 7/8" hole. An old spark plug with matching threads will avoid thread damage during the welding process. Weld all the way around the boss to insure a leak proof connection.

Install the oxygen sensor into the threaded boss and tighten securely. It is a good idea to add anti-seize to the threads to aid in removal.

3. On vehicles equipped with an AIR pump, the oxygen sensor must be mounted before the AIR injection into the exhaust, or the AIR pump must be disconnected. Holley recommends that if the AIR is injected into both exhaust manifolds, mount the oxygen sensor into the pipe immediately after the exhaust manifold. Disconnect the AIR pump tube from the exhaust manifold and plug both ends. Check with local ordinances for the legality of this procedure in your area.

WARNING! Failure to disconnect the AIR pump or locating the oxygen sensor downstream from AIR injection will result in an extremely rich mixture which could cause drivability problems and severe engine damage.

10.0 SENSOR WIRING

NOTE: Holley offers a sensor connector kit that can be used with any harness – MPFI kits P/N 534-205 & Stealthram kits 534-213.

NOTE: The pin letters designated are the ones on the connector shell.

Throttle Position Sensor (TPS)

The Holley Throttle Body uses a three wire TPS. The following is the correct wiring hookup.

Pin A – 5-volt input
Pin B – Ground
Pin C – Output

Manifold Absolute Pressure Sensor (MAP)

The System comes with a 1 BAR MAP sensor. The following is the correct wiring hookup.

Pin A – Ground
Pin B – Output
Pin C – 5-volt input

Air and Coolant Temperature Sensors

The System comes with standard General Motor's two-wire sensors. The sensors can be wired in either direction.

Idle Air Control Motor (IAC)

The IAC Motor included is a Chrysler style. The motor contains two circuits that must be both connected properly. If the pins are reversed, the motor will either operate backwards, improperly, or will be damaged.

Pins A and D are a circuit. Pins B and C are a circuit.

To change from a GM style IAC to the Holley (Chrysler style) IAC, the following pins need to be changed:

<u>GM Connector</u>		<u>Holley Connector</u>
A	remains	A
B	changes to	D
C	changes to	B
D	changes to	C

11.0 MECHANICAL CHECKOUT BEFORE STARTING ENGINE

Before starting the engine, review and check off the following items:

- Are the electrical connections correct?
- Are all the fuel lines hooked up and correct?
- Is the throttle linkage hooked up?
- Have the fuel lines been leak checked?
- Are all the vacuum hoses connected?
- Are all the sensors installed and hooked up properly?

1. Reconnect the battery.
2. Install the fuse in the fuse holder on the wiring harness. Before attempting to start the engine, perform the following steps to ensure that the system is properly connected.
3. While listening carefully, turn the key to the RUN position. The fuel pump will turn on and run for a few seconds before being shut off by the ECU. This shutoff occurs when the key is in the RUN position and the ECU does not receive any engine speed signal. At the first startup of the system after installation, when the fuel system is dry, the fuel pump may need to run longer than a few seconds. This may require additional cranking time to get fuel to the fuel injectors. A fuel pressure gauge in the fuel supply line is an excellent way to tell whether the system is getting fuel. **DO NOT** crank the engine for more than 15 seconds at a time and always allow adequate starter cool-down time between cranking.
4. Make sure that there is no leakage from any fuel lines when the fuel system has been pressurized.
5. Ensure that all vacuum and port connections have been plugged or made. Now install the air cleaner.

DANGER! MOVE THE THROTTLE LINKAGE INTO THE WIDE-OPEN POSITION AND CHECK THAT IT DOES NOT INTERFERE WITH AIR CLEANER OR OTHER COMPONENTS OF THE ENGINE. MAKE SURE THAT IT RETURNS FREELY TO THE IDLE POSITION WHEN RELEASED. THROTTLE RETURN ACTION CAN BE ENHANCED BY ADDING ADDITIONAL SPRINGS THAT PULL THE THROTTLE INTO CLOSED POSITIONS. FAILURE TO TEST THROTTLE ACTUATION PERFORMANCE MAY CAUSE UNSAFE DRIVING CONDITIONS, WHICH COULD CAUSE SERIOUS INJURY OR DEATH.

6. Use the software to monitor some of the system parameters prior to engine startup.

APPENDIX 1 ENGINE APPLICATION AND SELECTION OF FUEL MANAGEMENT SYSTEM COMPONENTS

Injector Fuel Flow

Engine output is in direct relation to fuel supplied to the engine, however installing injectors, which are too big, will not make more power. Installing injectors that are too small can lead to engine damage. It is therefore very important to match the fuel injector flow characteristics to specific engine applications.

The following equation sizes fuel injectors for specific engine applications.

Injector Static Flow Rate [lb./hr.] = (Engine HP * BSFC) / (Number of injectors * DC of Inj.)

Engine HP = Realistic HP output estimate of the engine

BSFC = Brake Specific Fuel Consumption [lb./HP*hr.]. Good approximation 0.50

Duty Cycle of Injector = Maximum opening time of injector/cycle time.

Maximum Duty Cycle = 0.90

Example:

Engine HP = 400HP

Number of Injectors = 8

Injector Static Flow Rate [lb./hr.] = $(400 * 0.50) / (8 * 0.90) = >27.78$ lb./hr.

NOTE: If the application requires a static flow rate that falls in between two available injectors always use the next larger injector.

For the example above if only 25 lb./hr. and 30 lb./hr. injectors are available, choose 30 lb./hr. injectors.

INJECTORS	
522-191	Single Injector 19 PPH
522-198	8 pack Injectors 19 PPH
522-241	Single Injector 24 PPH
522-248	8 pack Injectors 24 PPH
522-301	Single Injector 30 PPH
522-308	8 pack Injectors 30 PPH
522-361	Single Injector 36 PPH
522-368	8 pack Injectors 36 PPH
522-421	Single Injector 42 PPH
522-428	8 pack Injectors 42 PPH
522-481	Single Injector 48 PPH
522-488	8 pack Injectors 48 PPH
522-661	Single Injector 66 PPH
522-668	8 pack Injectors 66 PPH
522-831	Single Injector 83 PPH
522-838	8 pack Injectors 83 PPH
522-121	Single Injector 120 PPH
522-128	8 pack Injectors 120 PPH

**Holley Performance Products
1801 Russellville Road
Bowling Green, KY 42101**

Technical Service: 1-270-781-9741

**For online help, please refer to the Technical Information section of our website:
www.holley.com**

199R10580

Revision Date: 11-23-15