



BILLET FUEL PRESSURE REGULATOR REBUILD KIT

P/N 12-866 & 12-867

(For P/Ns 12-851, 12-852, 12-864, & 12-865)

P/N 12-852 EXPLODED VIEW			
ITEM	QTY	DESCRIPTION	TORQUE SPECS
1	1	REGULATOR BODY	
2	1	DIAPHRAGM ASSEMBLY	
3	1	SPRING	
4	1	SPRING GUIDE	
5	4	REGULATOR CAP	
6	4	5/16 – 24 NUT	90 – 125 IN/LBS
7	1	5/16 – 24 X 1.75 SET SCREW	
8	1	BRACKET	
9	4	#10 SPLIT LOCK WASHER	
10	4	10 – 24 X 1.38 SCREW	20 – 30 IN/LBS
11	1	1/8 NPT PLUG	20 – 30 IN/LBS

- Loosen lock nut (6) and turn adjusting screw (7) counterclockwise to remove tension from regulator spring.
- Remove 4 assembly screws (10). Set aside for reuse.
- Remove the bracket (8), cap assembly (5), retainer (4), and spring (3). Set aside for reuse.
- Replace the diaphragm assembly (2). **Make certain that the ball side of the diaphragm is pointed down.**
- Assemble the spring (3) and retainer (4).
- Reinstall cap assembly (5) and bracket (8).
- Install the 4 assembly screws (10) and torque to 20 – 30 in./lbs.
- Readjust screw (7) as necessary to achieve correct fuel pressure on engine, then tighten lock nut (6).

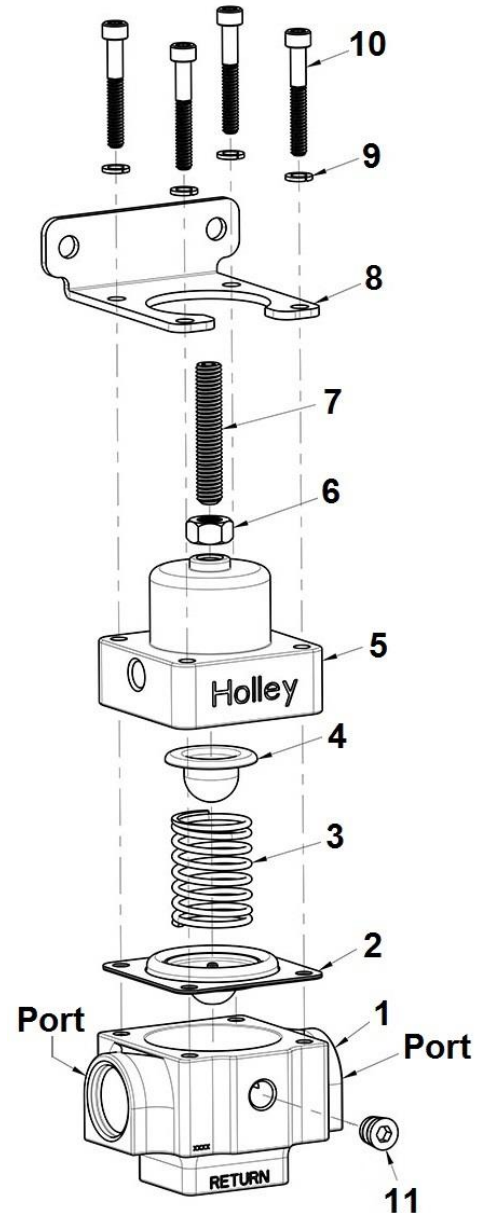

P/N 12-865 EXPLODED VIEW			
ITEM	QTY	DESCRIPTION	TORQUE SPECS
1	1	REGULATOR BODY	
2	1	DIAPHRAGM ASSEMBLY	
3	1	SPRING	
4	1	SPRING GUIDE	
5	1	REGULATOR CAP	
6	1	5/16 – 24 NUT	90 – 125 IN/LBS
7	1	5/16 – 24 X 1.75 SET SCREW	
8	1	BRACKET	
9	4	#10 SPLIT LOCK WASHER	
10	4	10 – 24 X 1.38 SCREW	20 – 30 IN/LBS
11	1	1/8 NPT PLUG	20 – 30 IN/LBS

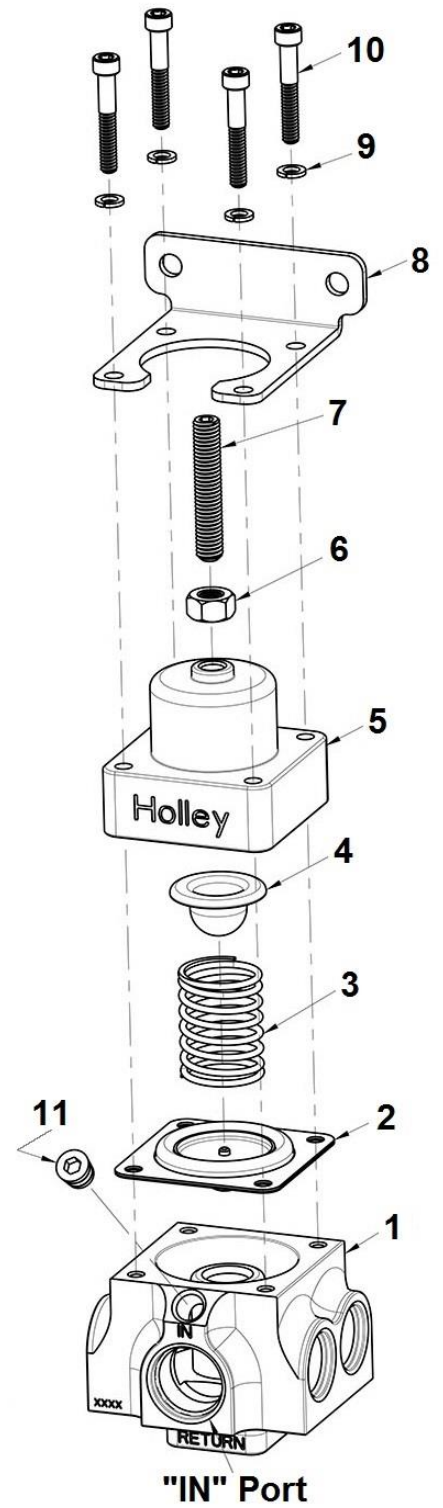

P/N 12-851 EXPLODED VIEW			
ITEM	QTY	DESCRIPTION	TORQUE SPECS
1	1	REGULATOR BODY	
2	1	DIAPHRAGM ASSEMBLY	
3	1	SPRING	
4	1	SPRING GUIDE	
5	1	REGULATOR CAP	
6	1	5/16 – 24 NUT	90 – 125 IN/LBS
7	1	5/16 – 24 X 1.75 SET SCREW	
8	1	BRACKET	
9	4	#10 SPLIT LOCK WASHER	
10	4	10 – 24 X 1.38 SCREW	20 – 30 IN/LBS
11	1	1/8 NPT PLUG	20 – 30 IN/LBS

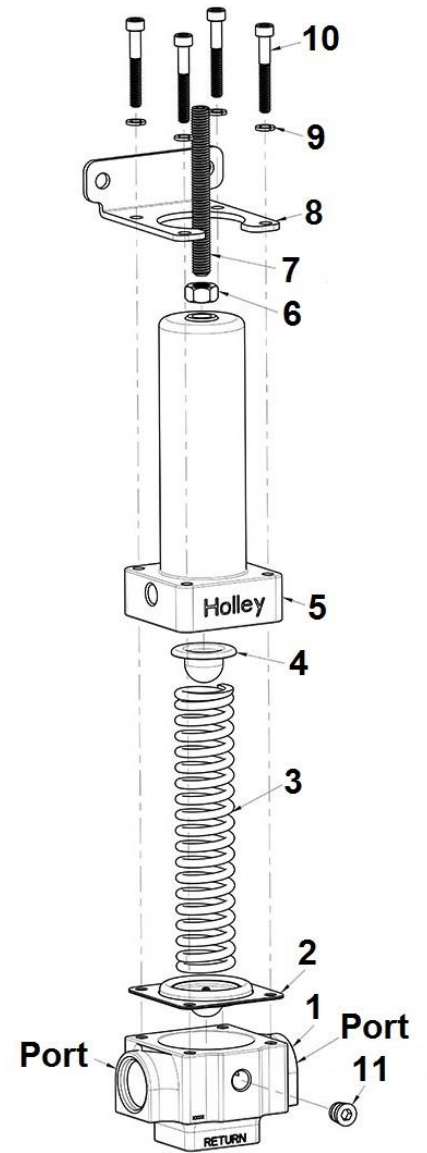

P/N 12-864 EXPLODED VIEW			
ITEM	QTY	DESCRIPTION	TORQUE SPECS
1	1	REGULATOR BODY	
2	1	DIAPHRAGM ASSEMBLY	
3	1	SPRING	
4	1	SPRING GUIDE	
5	1	REGULATOR CAP	
6	1	5/16 – 24 NUT	90 – 125 IN/LBS
7	1	5/16 – 24 X 1.75 SET SCREW	
8	1	BRACKET	
9	4	#10 SPLIT LOCK WASHER	
10	4	10 – 24 X 1.38 SCREW	20 – 30 IN/LBS
11	1	1/8 NPT PLUG	20 – 30 IN/LBS

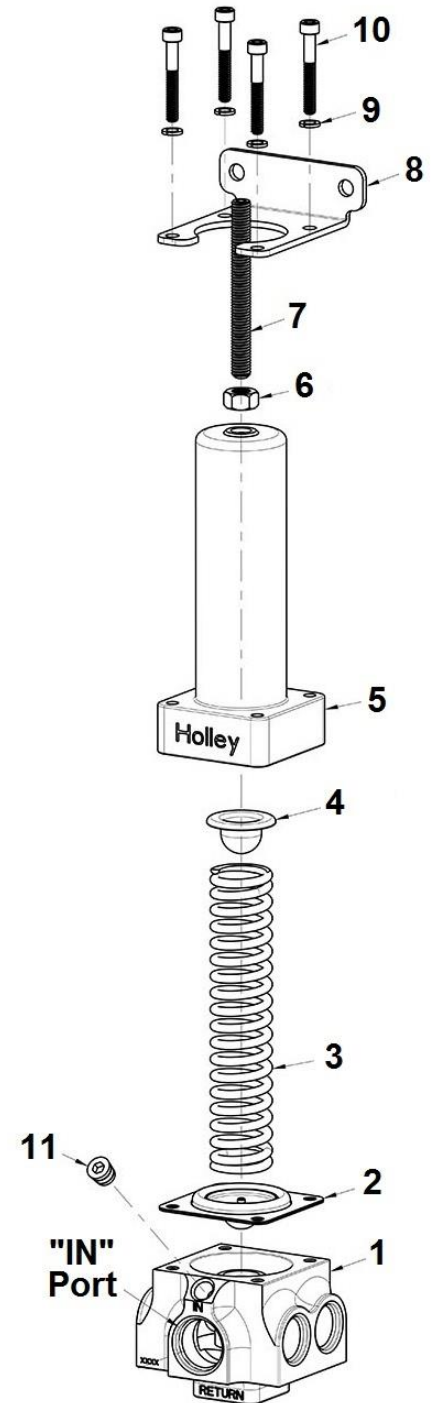

For further questions, please contact our technical department at 1-866-464-6553.
www.holley.com

© 2015 Holley Performance Products, Inc. All rights reserved.

199R10758

Revision Date: 4-13-16