



**Universal Electric Fan Harness & Relay Kit – Available for 185° or 195° Thermostat  
Part # 40102G & 40105G  
Installation Instructions**

**NOTE:** Use paste pipe thread sealant (i.e. D024ERL) on the threads on the temperature switch. Do **NOT** use plumber's sealing tape on the threads of the temperature switch since this insulates the switch from ground and it will not work correctly. This fan kit can be used with one or two electric fans as long as the total amperage draw does not exceed 30 amps. Check for coolant leaks before starting the vehicle.

Route the wires away from heat and sharp metal edges that may cause melting or damage to the wires. Use crimping tools or solder and heat shrink tubing when making wiring connections. Do not use electrical tape to hold the wires together.

1. For best results, mount the relay as close as possible to the electric fan.
2. Use the sheet metal screw to mount the relay connector to the vehicle.
3. Mount the thermostwitch into the cylinder head or intake manifold, so that the bottom of the switch is immersed in coolant. Route and connect the GREY 18-gauge wire to the thermostwitch. Crimp the 1/4" spade connector to the GREY wire and attach to the thermostwitch.
4. Route and connect the BLUE 12-gauge wire to the POSITIVE (+) wire on the electric fan motor. Some fans can be run in reverse, by connecting this wire to the NEGATIVE (-) wire on the electric fan motor (some fans cannot be run in reverse using this method).
5. Mount the circuit breaker near the power source you will be using to power the fan(s).
6. Route and cut the RED 10-gauge wire so that it terminates near the circuit breaker. Use the ring crimp terminals to connect the circuit breaker in-line with the power circuit. Note the circuit breaker will make a "pop" sound if the system is overloaded, and will automatically reset once it has cooled down. Keep your hands clear of the fan since it may restart automatically when the circuit breaker resets.
7. Route the YELLOW 18-gauge wire to the ignition switch or manually controlled fan switch (for driver control of the electric cooling fan).

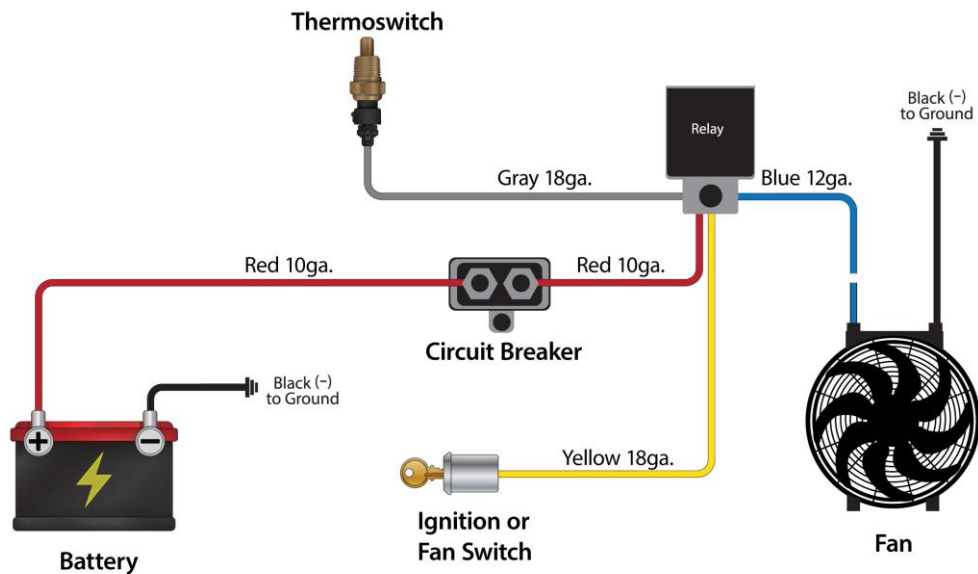

© 2018 Holley Performance Products. All Rights Reserved. Tous Droits Réservés.

**199R11497**

**Revision Date: 1-22-18**