



Sniper EFI Fuel Kits P/N 526-9 (20 ft. hose) & 526-10 (40 ft. hose)

1.0 FUEL SYSTEM INSTALLATION

DANGER! Take precautions to ensure that all fuel components are away from heat sources, such as the engine or exhaust pipes. A fire or explosion hazard could cause serious injury or death!

DANGER! Before disconnecting or removing fuel lines, ensure the engine is cold. Do not smoke. Extinguish all open flames. An open flame, spark, or extreme heat near gasoline can result in a fire or explosion causing property damage, serious injury, and/or death.

DANGER! Never get under a vehicle supported only by a jack. Serious injury or death can result from vehicles falling off of jacks. Before working underneath a vehicle, support it solidly with jack stands.

1.1 Parts Identification

ITEM	DESCRIPTION	QTY	SERVICE PART
1A	20 FT - 3/8 I.D. EFI Vapor Guard Hose	1 = 20 ft.	752066ERL (526-9)
1B	20 FT - 3/8 I.D. EFI Vapor Guard Hose	2 = 40 ft.	752066ERL (526-10)
2	Post Fuel Filter 10 micron	1	Holley P/N 562-1 or NAPA P/N 3482
3	Vapor Guard Hose Clamp, Size 8	7	750006ERL
4	1/4 NPT MALE STR TO 3/8 VAPOR GUARD HOSE	3	781606ERL
5	-6 ST. to 3/8 Vapor Guard Hose End	2	750166ERL (526-5 ONLY)



1



2



3



4



5

1.2 Fuel Line and Filter Installation

1. Use **Figure 1** below as a reference for the orientation and location of the fuel system components:

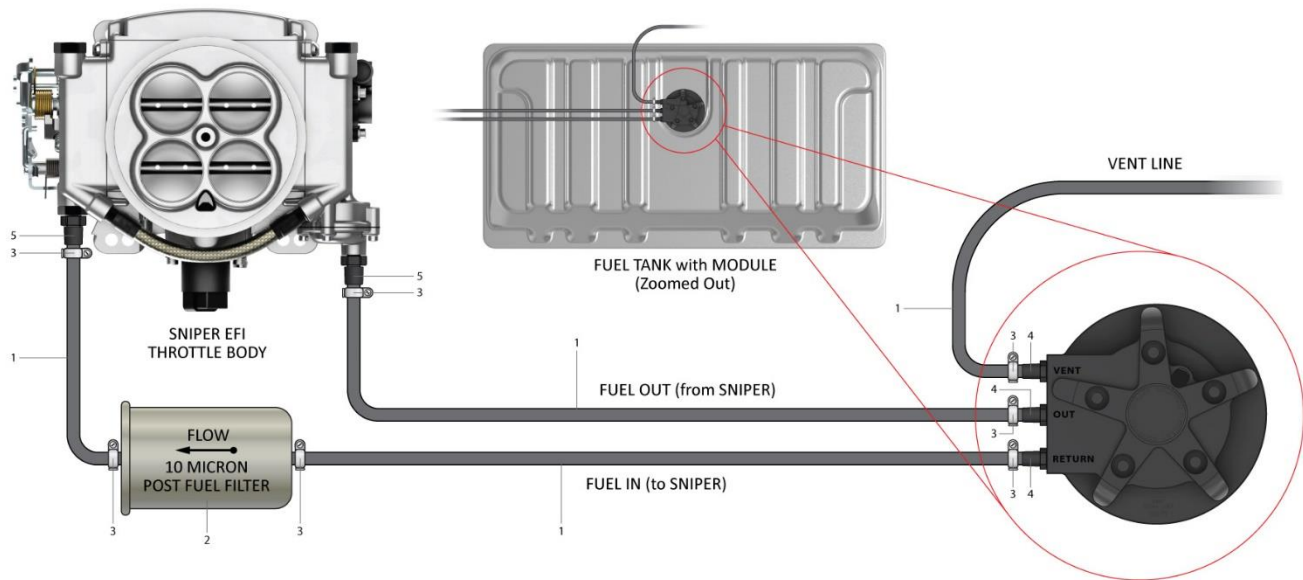

Figure 1 – 526-10 shown above

2. The post-fuel filter (**Item 2**) should be installed between the electric pump outlet and TBI unit. This is a 10 micron EFI filter. Position the filter, so the fuel hoses can be routed without kinks or sharp bends. The filter should be installed with the arrow on the filter pointing in the direction of the fuel flow (Figure 1).

WARNING! Ensure the filter is installed in the proper direction. A flow direction arrow is printed on the side of the filter to indicate the direction of fuel flow. Failure to do so will result in a system malfunction.

1.3 Fuel Line Installation

You are now ready to install the fuel lines. Some connections will use hose clamps (**Item 5**), while others will use AN hose ends (**Item 5**). These connections are noted in **Figures 1**. Be sure to read and thoroughly understand all steps, notes, and hose assembly instructions (**Section 1.3**) below before proceeding with the fuel line installation.

DANGER! Failure to use a fuel hose that meets SAE J30 standards could result in fuel leaks. A fuel leak may result in a fire or explosion hazard, which could cause serious injury or death.

1. If using steel line, the hose (**Item 1**) can be used to connect the steel line to the pump and filters. You should not connect a rubber hose directly to a steel line unless the end of the line has a “bead/nipple” or barb that retains the hose. If the steel line is just cut off, purchase a compression fitting that a barbed hose end can be installed on, or use a tool to roll a bead/nipple on the end of the steel line.
2. If you plan to install a fuel pressure gauge, do so at this time. The Sniper EFI systems are designed for an operating pressure of 58-65 PSI.
3. If using the existing fuel lines, inspect and replace any hose, clamps, or fuel line showing **ANY** sign of aging.
4. Anchor all fuel lines securely to solid chassis members at 1 ½ foot intervals using rubber coated steel clamps (not supplied).

1.4 Hose Assembly

1. Cut the hose square with a sharp knife.
2. Lubricate the inside of the hose and the outside of the nipple. Use assembly lube or engine oil. Do not use a silicon-based lube.
3. Push the hose end into the hose until it bottoms.
4. Install the clamp and tighten.
5. Blow the assembly clean and pressure test before running the car.

Diagram

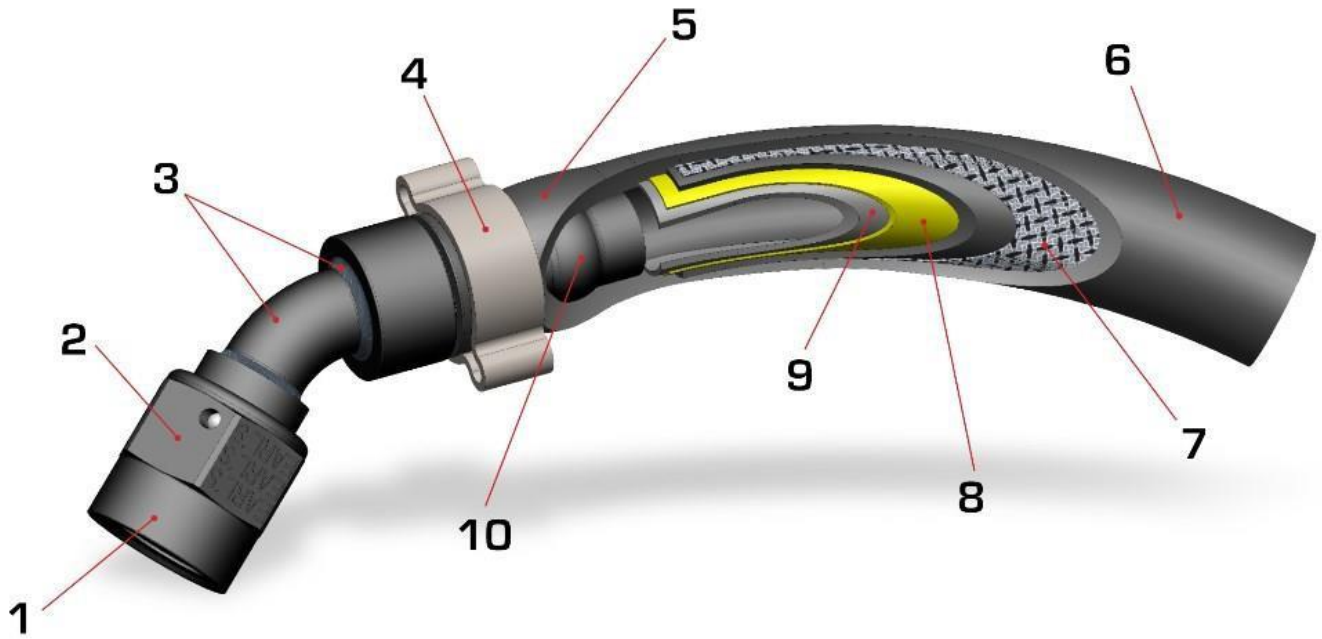

1. Black brite dip anodizing offers long-life even when used with today's harsh fuels
2. AN,SAE port & NPT hose ends available
3. Brazed bent-tube assembly provides unsurpassed strength
4. Three styles of stainless steel clamps available
5. Hose ends are adjustable in orientation after assembly for final clocking during installation
6. Exterior Cover - Extreme tolerance of heat and ozone
7. Reinforcement Braid - Aramid material (EFI hose only) is used to provide the high pressure rating that fuel injection requires
8. Vapor Guard Barrier - Thermoplastic layer provides superior fuel isolation virtually eliminating vapors from escaping through the hose
9. Primary Barrier Liner - Initial layer offers high resistance to heat and aggressive fuels
10. Vapor-Guard Retention Bead - retains hose under pressure while assuring hose liner is not damaged

Figure 4

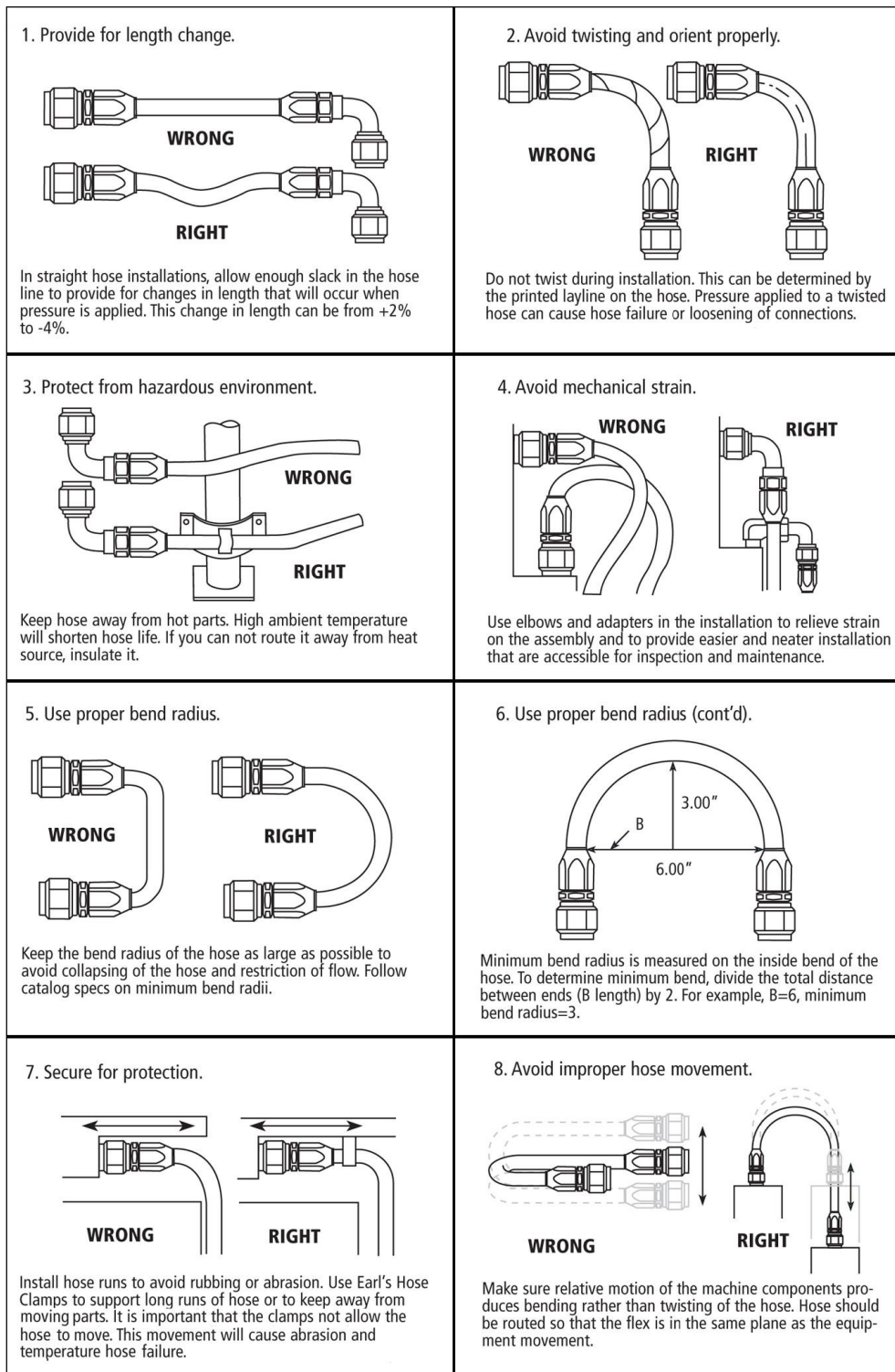

Figure 5

Holley Technical Support: 1-866-464-6553

© 2018 Holley Performance Products. All Rights Reserved. Tous Droits Réservés.

199R11532

Revision Date: 2-4-20