



POP OFF VALVE INSTALLATION P/N 7157WIN

1. Install the pop off valve after the manifold is on the engine.
2. Using a Teflon sealer or equivalent on the threads, install the gasket, pop off valve plate, springs, spring retainers, studs, and nuts to the intake manifold.
3. Installed spring height, measured from the manifold surface to the top of the spring retainer, should be approximately 1-3/4".

Holley Performance Products
1801 Russellville Rd.
Bowling Green, KY 42101
Technical Service: 1-270-781-9741

199R11600

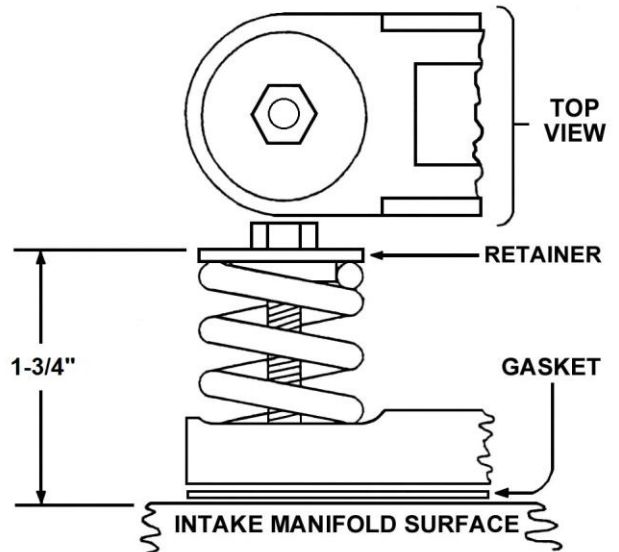

POP OFF VALVE INSTALLATION P/N 7157WIN

1. Install the pop off valve after the manifold is on the engine.
2. Using a Teflon sealer or equivalent on the threads, install the gasket, pop off valve plate, springs, spring retainers, studs, and nuts to the intake manifold.
3. Installed spring height, measured from the manifold surface to the top of the spring retainer, should be approximately 1-3/4".

Holley Performance Products
1801 Russellville Rd.
Bowling Green, KY 42101
Technical Service: 1-270-781-9741

199R11600

