



7506HKR (Black 75-82 Corvette 396-502)
7506-1HKR (Coated 75-82 Corvette 396-502)
7509HKR (Chrome 75-82 Corvette 396-502)

SUPER COMPETITION SIDEMOUNT HEADERS

NOTES

1. Requires purchase of side tube, P/N 50735HKR for 7506HKR, 50735-1HKR for 7506-1HKR, and 65284HKR for 7509HKR.
2. Hooker mufflers 21021HKR (glass pack), 21003HKR (reverse flow design for maximum sound control), or 21046HKR (Max Flow sidepipe muffler, slip in design) to be used with 4" sidepipes.
3. Factory style big block frame stands and motor mounts must be used to ensure proper engine locations and header fit.

Thank you for making HOOKER HEADERS your choice in a high-performance exhaust system. Extensive dyno/track testing has enabled HOOKER to offer the most advanced design in headers for your application. Due to the restricted room available in the engine compartment, your headers may be close to some body and chassis components. This condition is normal. The installation, while not complex, may be time-consuming. However, as soon as you start your engine, the additional horsepower and improved performance will more than justify your efforts. Proper installation and maintenance will ensure long life and maximum performance from your HOOKER HEADERS.

WARNING! Breaking in an engine with ceramic-coated headers WILL result in damage to the coating and will VOID all warranties. Ceramic-coated headers require several heat cycles to fully cure before they will withstand extreme heat. HOOKER recommends using a cast-iron exhaust manifold or an old header to break in new engines to avoid coating damage.

BEFORE STARTING

Your vehicle must be raised a minimum of 36 inches, so a floor hoist is ideal. If no hoist is available, we strongly urge the use of axle stands as a safety measure.

CAUTION! YOUR CAR SHOULD NOT BE SUPPORTED ON A BUMPER JACK.

INSTALLATION PROCEDURE – PLEASE READ CAREFULLY

LEFT SIDE:

1. Disconnect the battery to prevent electrical system damage. Remove the spark plugs and (if manual trans) clutch linkage.
2. Starting from below, work the head up through the chassis into position over the exhaust ports. Insert the gasket between the flange and head. Start all header bolts (most restricted first).

NOTE: If the engine is equipped with an electric oil pressure unit, it will be necessary to purchase a 90° elbow (1/4" male/female pipe fitting) and install it in the block as an adapter so the sending unit will clear the L-4 header tube. See **Figure A**.

3. Slide the sidepipe over the collector. Support the rear of the sidepipe with props.
4. Adjust the position so the holes in the brackets align with the slots in the frame. Insert the heads of the tab bolts into the slots and rotate them 1/4 turn. Using the furnished rubber grommets, flat washers, lockwashers, and nuts, attach the side pipe brackets to the frame, but do not tighten. See **Figure B**.
5. Tighten the sidepipe mounting bolts/nuts. Replace and/or secure the rocker panel molding. Tighten all the header bolts evenly.
6. Replace the clutch linkage and spark plugs. Spark plug wires must be rerouted for adequate heat protection.

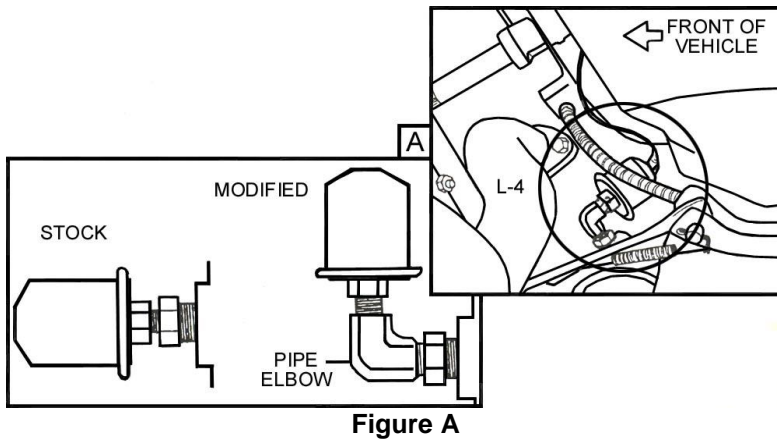

Figure A

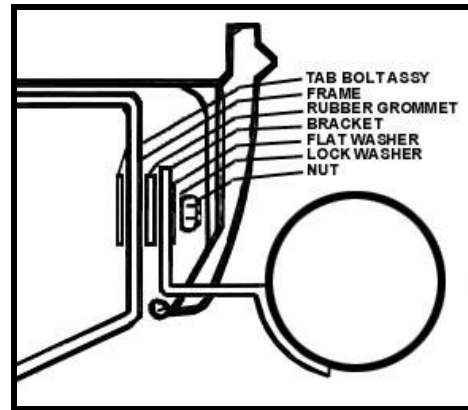

Figure B

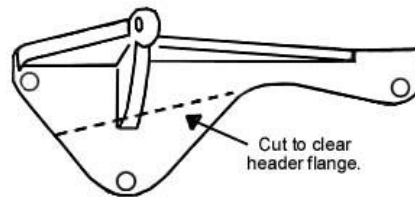

Figure C

RIGHT SIDE:

1. Remove the spark plugs, dipstick tube, and (if equipped) air conditioning compressor.
2. Follow the same procedure as the left side (from step 2 to step 6) to complete the installation.

NOTE: If equipped with air conditioning, it may be necessary to modify the compressor bracket, according to **Figure C**.

3. Replace the spark plugs and dipstick tube. Connect the battery, start the engine, and check for leaks. Be sure all brake lines, fuel lines, and electrical wires have sufficient clearance. Reroute, as necessary. When finished, give your car a test drive, checking carefully for any new noises. After several days driving, retighten all bolts.

Any questions? Please contact Technical Service: 1-866-464-6553 or 270-781-9741. For online help, please refer to the website: www.holley.com.

LIMITATION OF LIABILITY – DISCLAIMER:

The regulation of emissions production, noise levels, and safety standards is undertaken by the federal government, each of the fifty state legislatures, and by many local municipalities, towns, and counties. HOOKER makes no warranties of merchantability, of fitness for particular purpose, or that its products are approved for general use, or that its products are approved for general use, or that its products comply with laws, regulations, or ordinances in the state where they may be sold to the ultimate purchaser, the consumer. Unless expressly stated to the contrary in the catalog, instruction sheet, or price list, the entire risk as to the conformity of any company product in any such state and as to repair should the product prove to be defective or non-conforming, is on the retail purchaser, the buyer, the ultimate consumer, of such product and it is not upon the seller, distributor, or manufacturer. In this connection, the retail purchaser, the buyer, the ultimate consumer assumes the burden of the entire cost of any and all necessary service, alterations, or repair.

THE FOREGOING STATEMENT LIMITS THE LIABILITY OF THE MANUFACTURER.

California vehicle code, sections 27156 and 38391, prohibits the advertising, offering for sale, or installation of any device, which modifies a vehicle's emission control system, unless exempted, unless otherwise noted. HOOKER™ Headers that have not received an Executive Order (E.O.) exemption from these code sections are not legal for sale or use in California on vehicles originally equipped with catalytic converters, except for racing vehicles, which may never be driven upon a highway. Check with your local authorities to determine if these headers are legal for use in your particular area.

199R11839

Date: 5-15-19