

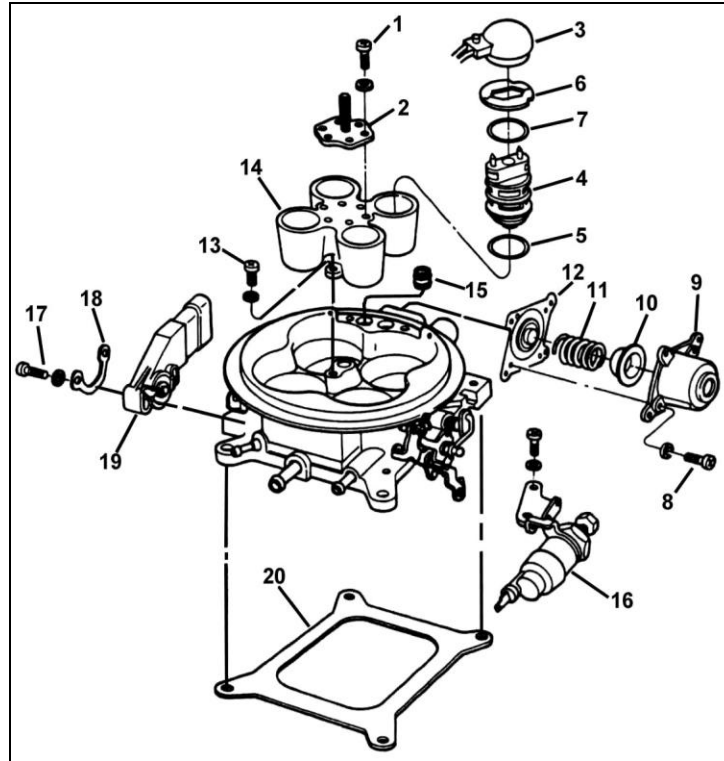

THROTTLE BODY INJECTION MODEL 3400 AND 3400 PRO-JECTION INSTALLATION INSTRUCTIONS

TYPICAL VIEW—3400*



*The exploded view shown is typical of the model T.B.I. this kit will service, the view may differ slightly from the actual T.B.I. being renewed.

NONMENCLATURE

REF. NO.		REF. NO.	
1	Air Cleaner Stud Assembly	11	Pressure Regulator Spring
2	Injector Clamp	12	Pressure Regulator Diaphragm Assembly
3	Injector Caps & Connector Assembly	13	Fuel Meter Body Screw
4	Fuel Injector	14	Fuel Meter Body
5	O-Ring	15	Fuel Meter Body O-Ring
6	Injector Flange	16	Fast Idle Solenoid
7	O-Ring	17	Throttle Position Sensor Screw & L.W.
8	Fuel Meter Cover Screw	18	Throttle Position Sensor Retainer
9	Fuel Meter Cover	19	Throttle Position Sensor
10	Pressure Regulator Spring Retainer	20	Flange Gasket

REMOVAL

Model 3400—Leave the engine off for at least one hour after running it to relieve fuel pressure. Follow the normal service procedures to remove the T.B.I. assembly from the intake manifold.

DISASSEMBLY

Rest the T.B.I. assembly on a repair stand to avoid damage to the throttle plate and electrical connections during the renew procedures. Use the exploded view as a guide, and follow the numerical sequence, in general, to disassemble the unit far enough to permit cleaning and inspection.

CAUTION: The pressure regulator contains a large spring under heavy compression which, if accidentally released, could cause personal injury. To disassemble remove two pressure regulator cover screws opposite each other. Reinstall them three turns, then slowly remove the other two screws evenly to relieve spring tension. While holding the regulator cover, remove the remaining screws.

FUEL INJECTORS—Use care when removing the injectors, as the electrical connectors, injector fuel filter, and nozzle are easily damaged.

CLEANING

Cleaning must be done with the throttle body disassembled. Soak the parts long enough to soften them and remove all foreign material. Use a carburetor solvent, lacquer thinner, or denatured alcohol. Make certain the throttle body is free of all hard carbon deposits. Wash it off in a suitable solvent. Blow out all passages in the castings with compressed air and check carefully to ensure thorough cleaning of obscure areas.

CAUTION: Do not soak parts containing rubber or plastic material. The injectors should never be immersed in cleaner, as damage may result.

REASSEMBLY

Reassemble in the reverse order of disassembly. Note the special instructions and follow the outline in making adjustments.

Manually operate the throttle lever, checking for binding or other malfunctions. Any binding or interference could cause the throttle to stick during operation and could result in the loss of throttle control (or uncontrolled engine speed).

Check the fuel component connections for leaks, and correct immediately.

SPECIAL INSTRUCTIONS

Fuel Injector - Lubricate the "O" rings with automatic transmission fluid before installing.

Pressure Regulator Diaphragm - When installing the diaphragm, hold it in place by inserting the two installation pins through two bolt holes opposite each other. After the pressure regulator cover is on with two screws started, remove the installation pins.

Fast Idle Adjustment - For model 3400, adjust the fast idle solenoid by turning the hex head. Adjust the fast idle to the vehicle manufacturer's specifications.

ECU Adjustment - For model 3400, it may be necessary to readjust the computer. Refer to your Pro-Jection installation manual for the proper procedures.

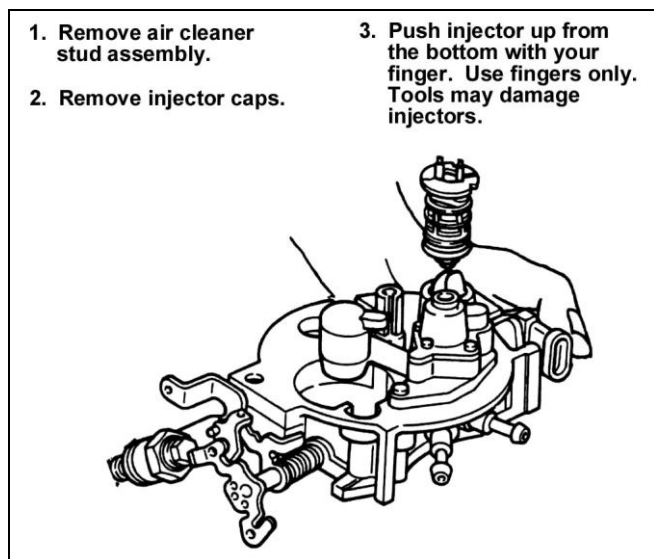

Figure 1—Fuel Injector Removal

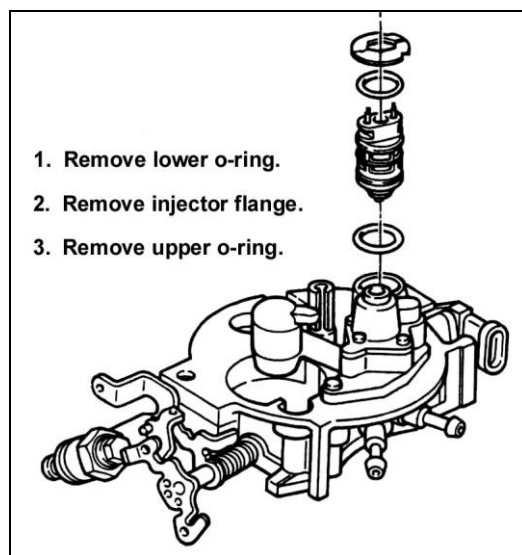

Figure 2—Fuel Injector Removal

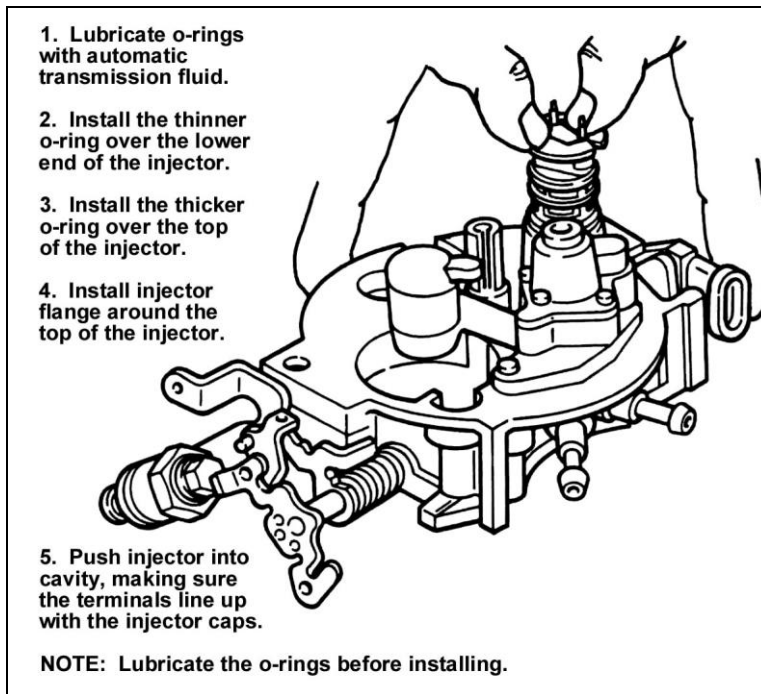

Figure 3—Fuel Injector Installation

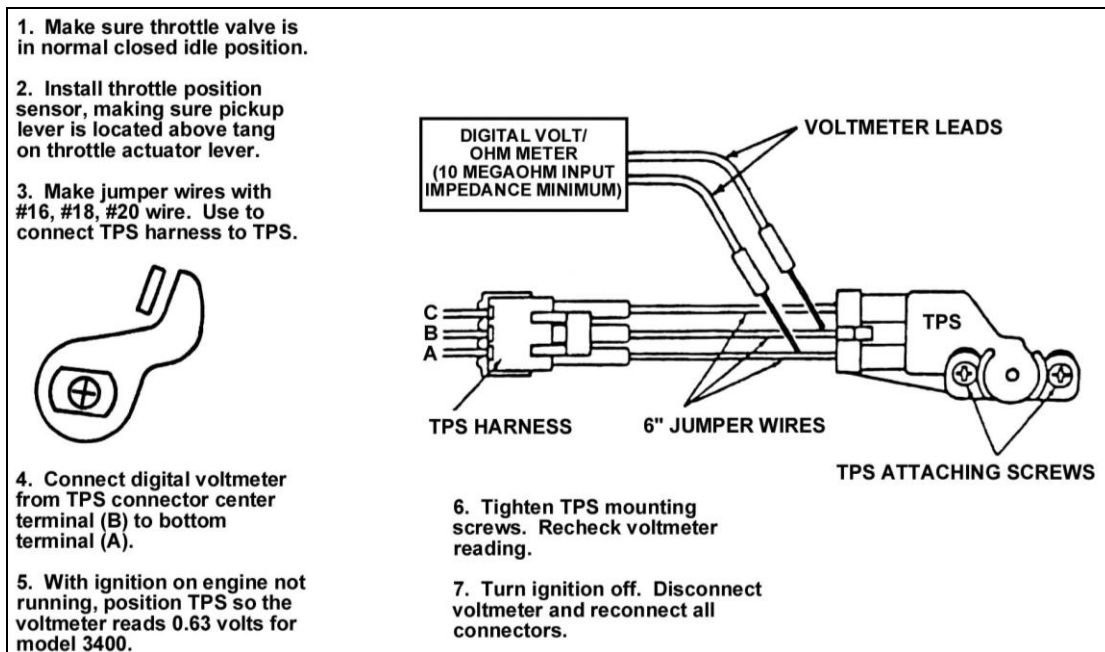

Figure 4—Throttle Position Sensor Installation and Adjustment

SERVICE PROCEDURE FUEL SYSTEM PRESSURE TEST AND ADJUSTMENT

This test must be performed when checking and adjusting the fuel system.

Tools required: Fuel Pressure Gauge Kits

Kent Moore	J29658 or J34020
or	
Snap On	MT321 C
or	
Borrough's	BT-82058

CAUTION: It is necessary to relieve the fuel system pressure before servicing the fuel system components. Fuel spray will occur if the following procedure is not followed.

To relieve the fuel system pressure:

1. **Model 3400-** Leave engine off for at least one hour after running it to relieve fuel pressure.

NOTE: Do not turn the key to the run position until the fuel pressure gauge is installed.

2. Remove air cleaner and plug vacuum ports.
3. Install a fuel pressure gauge at the fuel inlet to the throttle body.
4. Start the car and observe the fuel pressure reading. It should read 15 P.S.I. Place a 5/16 Allen wrench into the adjusting screw that is located on the BACK of the fuel pressure regulator cover and turn the screw to adjust the pressure.
5. Depressurize fuel system, then remove fuel pressure gauge.
6. Reinstall fuel line.
7. Start car and look for any fuel leaks.

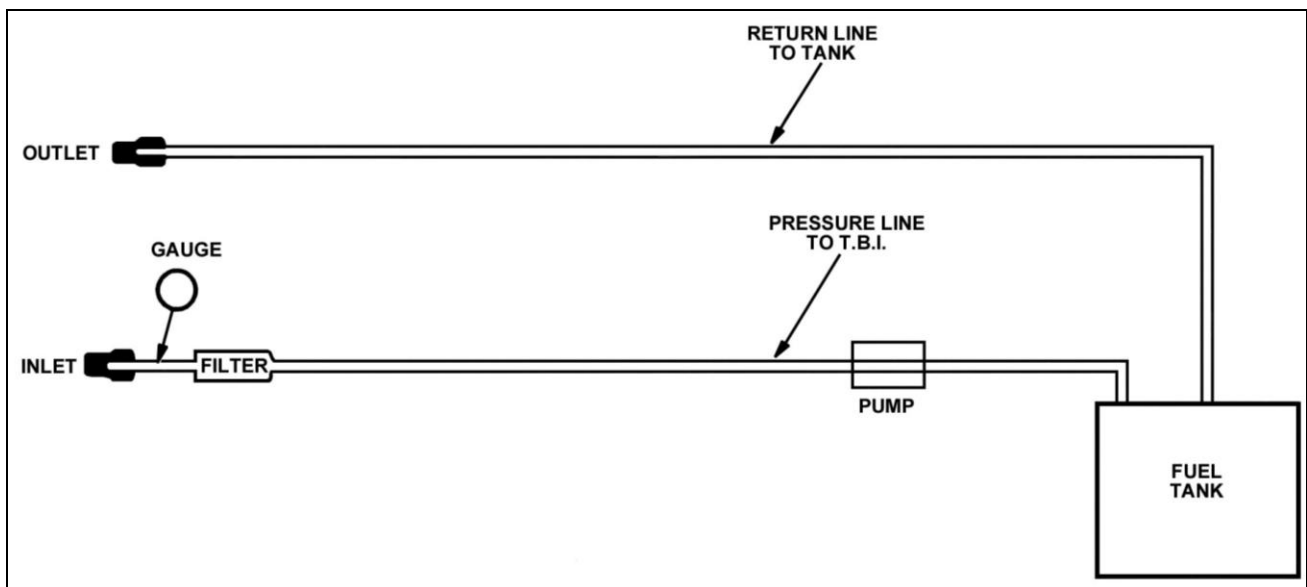

Figure 5

**Holley Performance Products
1801 Russellville Road
Bowling Green, KY 42101**

**Technical Service: 270-781-9741
Fax: 270-781-9772**

For online help, please check the Tech Service section of our website: www.holley.com