



**2241HKR (Black), 2241-1HKR (Coated), 2241-3HKR (Stainless), & 2241-4HKR (Titanium)
SUPER COMPETITION ENGINE SWAP HEADERS
1978-87 Buick Regal – Chevy V8 (396-502)
1978-87 Chevy Chevelle, Malibu, Caballero, Monte Carlo, & El Camino (396-502)
1978-87 Oldsmobile Cutlass & Pontiac Grand Prix (396-502)**

Thank you for making HOOKER HEADERS your choice in a high-performance exhaust system. Extensive dyno/track testing has enabled HOOKER to offer the most advanced design in exhaust systems. The installation, while not complex, will take a certain amount of time. However, the additional horsepower and improved performance will more than justify your efforts. Proper installation and maintenance will ensure long life and maximum performance from your HOOKER HEADER exhaust system.

NOTE: Headers will only fit properly if stock small block frame stands and motor mounts are used.

WARNING! Breaking in an engine with ceramic-coated headers WILL result in damage to the coating and will VOID all warranties. Ceramic-coated headers require several heat cycles to fully cure before they will withstand extreme heat. HOOKER recommends using a cast-iron exhaust manifold or an old header to break in new engines to avoid coating damage.

BEFORE STARTING

Your vehicle must be raised a minimum of 36 inches. A floor hoist is ideal. If no hoist is available, we strongly urge the use of axle stands as a safety measure. **CAUTION! YOUR CAR SHOULD NOT BE SUPPORTED ON A BUMPER JACK.**

INSTALLATION PROCEDURE – PLEASE READ CAREFULLY

LEFT SIDE

1. Disconnect the battery to prevent damage to the electrical system.
2. Unbolt the headpipes from the stock exhaust manifolds and push aside.
3. Remove spark plugs, oil filter, exhaust manifold, and heat shield from the motor mount, if so equipped.
4. Remove the center bolt from the motor mount and raise the engine approximately 2". Be sure to use a board between the oil pan and the jack. Modify the motor mount, as shown in **Figure A**.
5. Starting from below, work the main body of the header up through the chassis into position, leaving it loose at this time. From above, work the #3 slip tube around the steering column and into the main body of the header. Lower the engine and replace the motor mount bolt.
6. Position the gasket and start all the bolts (most restricted first).
7. Tighten all the header bolts evenly (most restricted first).
8. Replace the spark plugs and oil filter.
9. If the car is equipped with air conditioning with the long style compressor mounted on the left side, see **Figure B** (69-72 models) or **Figure C** (73-74 models). If you choose to utilize the late model axle compressor, brackets must be fabricated.

RIGHT SIDE

1. Remove spark plugs, dipstick tube, stock exhaust manifold, and starter.
- NOTE:** It may be necessary to trim the "A" arm bolt as shown in **Figure D**.
2. Starting from below, work the main body of the header up through chassis into position. Do not start any bolts at this time. From above work the #4 slip tube and then the #3 slip tube into the main body of the header.
 3. With the header loose, reinstall the starter.
 4. Insert the gasket and start all the header bolts (most restricted first).
 5. Install the dipstick tube and tighten all the header bolts evenly (most restricted first).
 6. To connect the collectors to the headpipes, purchase Hooker Header reducer kit P/N 11035HKR.
- NOTE:** A dual exhaust system can be fabricated using Hooker Competition Turbos #21005HKR or #21006HKR and a universal tailpipe.
7. Connect the battery, start the engine, and check for leaks. Be sure that all brake lines, fuel lines, and electrical wires have sufficient clearance. Reroute, as necessary.
 8. When finished, give your vehicle a test drive, checking carefully for any new noises. After several days of driving, retighten all the bolts.

Any questions? Please contact Technical Service: 1-866-464-6553 or 270-781-9741. For online help, please refer to the website: www.holley.com.

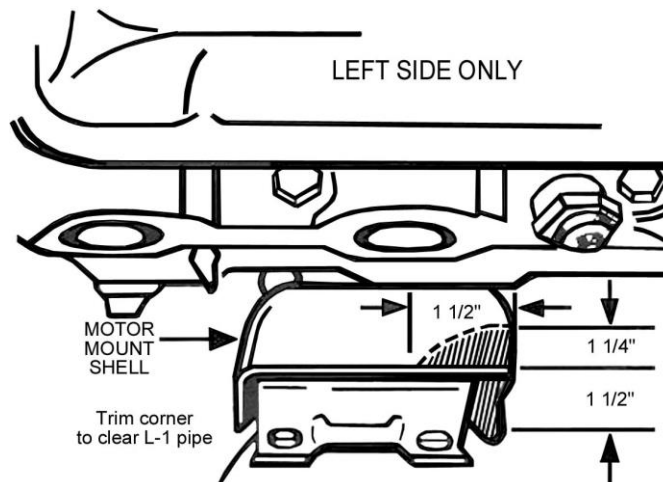

Figure A

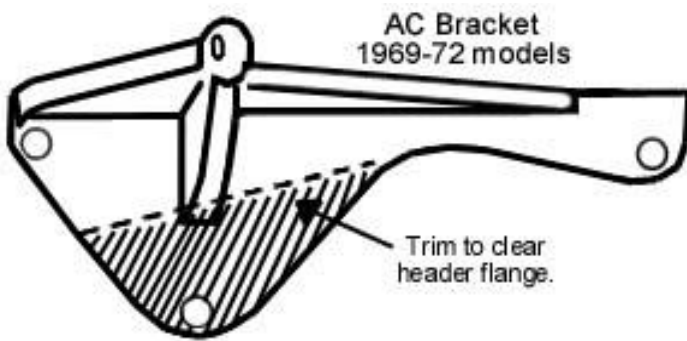

Figure B

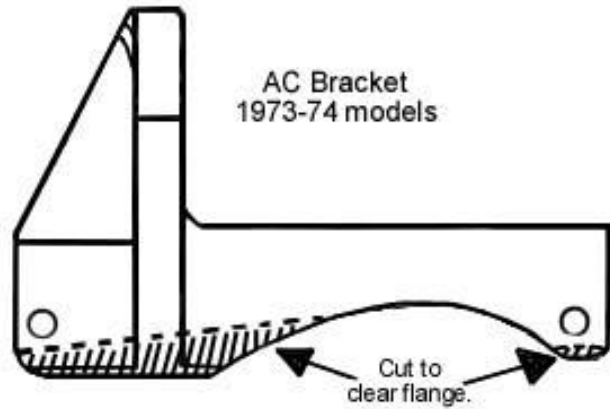

Figure C

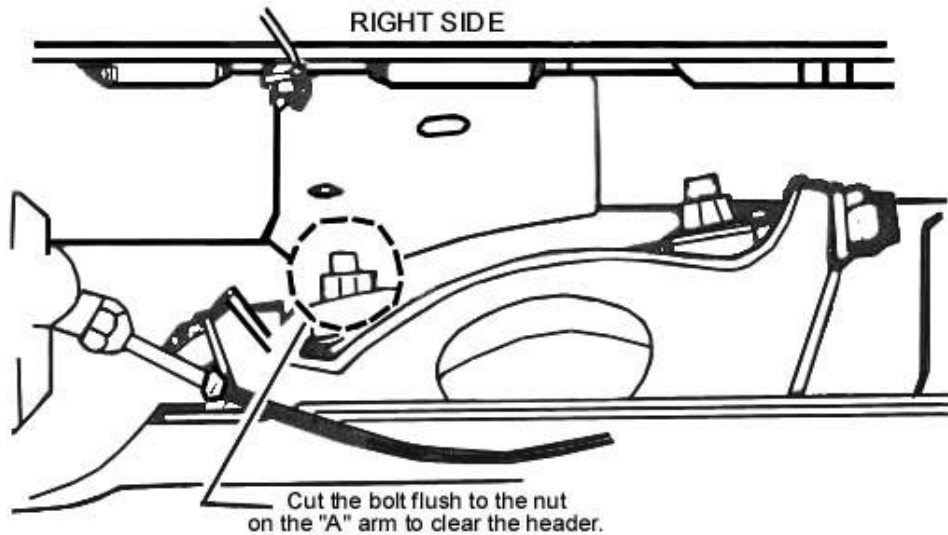

Figure D

LIMITATION OF LIABILITY – DISCLAIMER:

The regulation of emissions production, noise levels, and safety standards is undertaken by the federal government, each of the fifty state legislatures, and by many local municipalities, towns, and counties.

HOKKER makes no warranties of merchantability, of fitness for particular purpose, or that its products are approved for general use, or that its products are approved for general use, or that its products comply with laws, regulations, or ordinances in the state where they may be sold to the ultimate purchaser, the consumer.

Unless expressly stated to the contrary in the catalog, instruction sheet; or price list, the entire risk as to the conformity of any company product in any such state and as to repair should the product prove to be defective or non-conforming, is on the retail purchaser, the buyer, the ultimate consumer, of such product and it is not upon the seller, distributor, or manufacturer.

In this connection, the retail purchaser, the buyer, the ultimate consumer assumes the burden of the entire cost of any and all necessary service, alterations, or repair.

THE FOREGOING STATEMENT LIMITS THE LIABILITY OF THE MANUFACTURER.

California vehicle code, sections 27156 and 38391, prohibits the advertising, offering for sale, or installation of any device, which modifies a vehicle's emission control system, unless exempted, unless otherwise noted. HOKKER™ Headers that have not received an Executive Order (E.O.) exemption from these code sections are not legal for sale or use in California on vehicles originally equipped with catalytic converters, except for racing vehicles, which may never be driven upon a highway. Check with your local authorities to determine if these headers are legal for use in your particular area.

© 2002 Hooker Headers, Inc. All rights reserved.

2241HKR

Revision Date: 12-30-14