



## Installation Instructions V-Matic3 Installation kit

Catalog# 3730005

This kit includes the necessary brackets, levers and hardware required for the installation of the various the various Hurst V-Matic3 shifters (Cable and Shifter not included). This is an overview of the general installation procedures. For more detailed instructions please refer to the instruction sheet provided with the specific shifter part number that you are working with. These can also be found on our website.

**Note:** All adjustments must be made with shifter and transmission in Neutral (N). All adjustments are critical and **MUST** be precise.

Do not mix components (all parts including cable must be Hurst components provided in kit).

If a shifter is removed and reinstalled, adjustments must be checked and re-adjusted.

Always check cable for freedom of motion before connecting at shifter and transmission arm.

Routing of cable should avoid sharp bends (permanent damage of cable will result.)

The Hurst Vmatic3 shifter can be used in vehicles equipped with most popular 3-speed or four speed automatic transmissions.

Please read the instructions and review the illustrations thoroughly before beginning the installation. The mechanical components of this shifter are precision made and assembled at our factory. Any modification or disassembly of these parts can cause the shifter to malfunction and will void the warranty. You should disassemble only those items outlined in the instructions. The vehicle should be about 2 feet off the ground for ease of installation. Use jack stands, wheel ramps or a vehicle lift. Make sure the vehicle is firmly supported before attempting to work on it.

**IMPORTANT:** If your vehicle is equipped with a locking steering column, securing the column lock lever in the engine compartment in the full up position will allow the steering wheel to be locked and unlocked and the ignition key to be removed.

**WARNING:** This allows the steering wheel to be locked **WHENEVER** the ignition key is turned to the "lock" position **WHILE THE VEHICLE IS MOVING, OR AT ANY OTHER TIME**. Securing the steering column lock lever in any other position will both **PREVENT** the steering wheel from locking and removal of the ignition key.

### **WARNING**

**PERIODIC INSPECTION AND MAINTENANCE OF YOUR SHIFTER IS RECOMMENDED TO ENSURE THAT THE MECHANISM IS WELL LUBRICATED, FREE FROM DIRT OR RUST AND THAT THE CABLE IS PROPERLY ADJUSTED. LACK OF MAINTENANCE COULD RESULT IN A FAILURE INCLUDING A FAILURE OF THE REVERSE LOCKOUT SAFETY FEATURE.**

## INSTALLATION

**NOTE:** If you are installing this shifter with a four speed automatic transmission, you must remove the blocker pin and the two e-clips indicated in Figures 1 (on Page 12) and 3. Removing this blocker pin gives the shifter four forward positions rather than three. For Ford AOD four speed transmissions do not remove this blocker pin and the two e-clips, since this transmission has only three forward positions. Also do not remove the blocker pin and the two e-clips for three speed automatic transmissions.

### 1. Remove the stock shift linkage

**Column Shifters:** Remove all rods, levers or cables from the column and the transmission. Place the column shift lever in the Park position. Remove the pin holding the shift lever in the column and remove the lever assembly. If your vehicle is equipped with a locking steering column, secure the column lock lever in the full up position.

**Console Shifters:** Remove the shifter mechanism from the console. Disconnect the rod or the cable from the transmission. Remove the cable bracket if equipped. If there is a cable or linkage from the console shifter or the transmission to the steering column lock, it must be blocked in the Park position as described above.

**NOTE:** Shifter installation may require console modification or complete console removal depending on the space available in your vehicle.

2. Pull the carpet away from the floorboard where the shifter is to be mounted. If the vehicle has a bench type seat, move the seat to the full forward position. Place the shifter on the floor with the stick shifted to the rear-most gate position. Locate the shifter for ease and convenience of operation (See Figure 2). Make sure the trigger and T-handle clear the dash with the shifter in the Park position. Mark the position of four mounting holes on the floor.

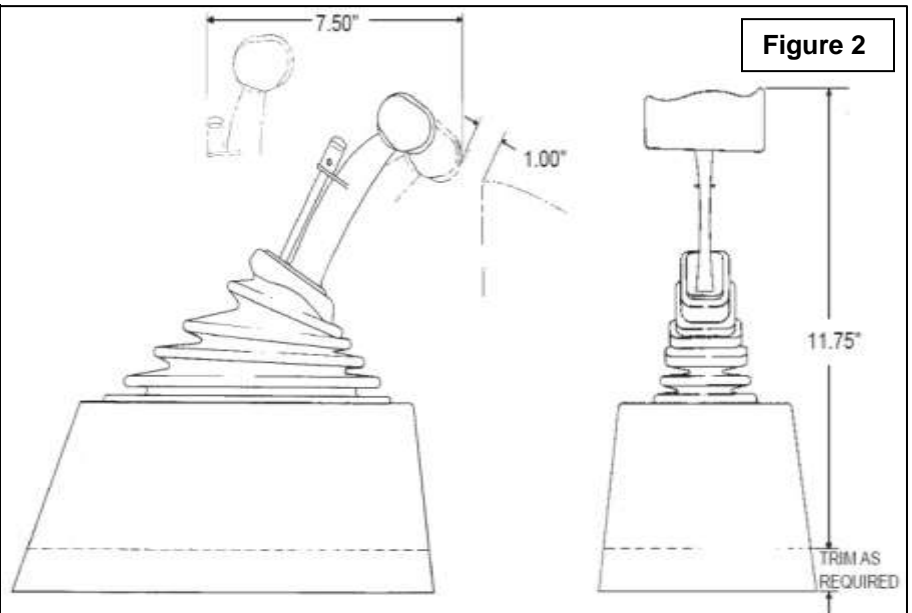

3. Drill four 9/32" mounting holes where marked. Temporarily mount the shifter in place using washers as required to get it level. **Do not bend the mounting brackets on the bottom of the shifter.** Mark the location for the shifter cable hole, 3" ahead of the left front shifter mounting hole. Drill or cut a 1-1/2" diameter cable hole in the floorboard.

**NOTE:** Some floorboards are extremely thin and will not adequately support the shifter mechanism when bolted to the floor. For those vehicles we recommend that you fabricate a stiffener plate for additional strength.

4. Install (but do not secure) the carpet back to its original position. Cut holes in the carpet for the mounting holes and the cable. **DO NOT** use a drill bit to make holes in the carpet.

5. Assemble the neutral safety and the reverse light switches to the bracket using two #4-40 x 1" screws and nuts, as shown in Figure 1. **Beware**, over tightening the switch attachment screws will crack the switch housings. Install the switch assembly on the shifter. To adjust the switches, loosen the screws and slide the switches in or out as required, then retighten the screws.

6. Install the cable on the shifter as shown in Figure 1. The cable attachment tab should be bolted to the outside surface of the shifter base using a 1/4" x 1/2" hex bolt, lock washer and nut. Install the E-clip that secures the cable to the cable pin.

7. Just before the final installation of the shifter in the vehicle, attach the indicator cable to the side of the shifter as shown in Figure 3. The indicator cable bracket is secured to the shifter mechanism with two #6 x 3/4" sheet metal screws and two #6 washers, the eyelet on the end of the indicator cable is secured to the cable pin by a supplied small e-clip.

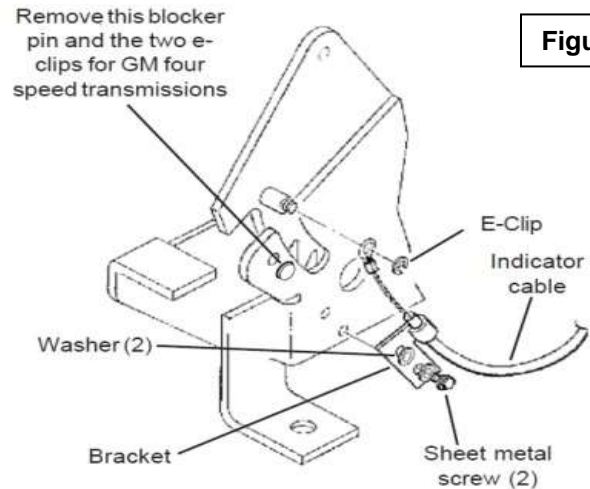

8. Install the shifter mechanism into the vehicle. Slide the shifter cable through the carpet and the hole in the floor. Bolt the shifter down using four 1/4" x 1-1/2" hex bolts and nuts. If required use 1/4" washers as shims between the shifter mechanism and the floor to level the shifter.

**ROUTE THE CABLE AS SHOWN IN FIGURE 4, AVOID SHARP BENDS WHICH WILL KINK AND DAMAGE THE CABLE.**

Use cable clamps or tie wraps to secure the cable housing to the chassis to avoid contact with hot engine or exhaust system.

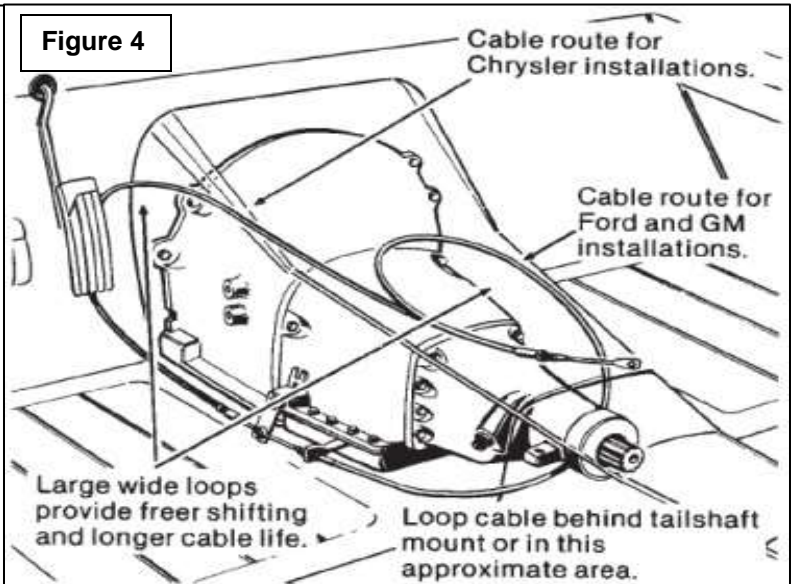

9. Seal the hole where the cable goes through the floorboards to prevent air or water leakage. A putty type sealer can be used. For General Motors vehicles go to Step 10, for Ford vehicles go to Step 15, for Chrysler vehicles go to Step 21.

## GENERAL MOTORS

10. If you have not already done so, remove the stock selector lever nut and the selector lever from the transmission. Discard the stock lever and the stock shifter linkage. Install the B&M selector lever in position using the stock selector lever nut (See Figure 5 on next page). Torque the nut to 23 lb. ft. The lever should move smoothly from front to rear with a positive click in each gear position.

11. Remove two transmission oil pan bolts from the middle of the left side of the oil pan. Install the cable bracket in position (See Figure 5). The bracket must be installed with two spacers between the pan and the bracket. (If your transmission is equipped with a cast aluminum oil pan, these spacers should be omitted. With a TH-400 with a cast aluminum oil pan, the cable bracket may have to be modified.) Install the two 5/16-18 x 1.00" bolts (Metric transmissions use the two 8mm x 25mm bolts) supplied and tighten 12-13 lb.ft. Do not overtighten as this can damage the pan gasket.

12. Route the shifter cable according to Figure 4. Avoid kinks and sharp bends and route the cable away from hot engine or exhaust parts. Remove the two rubber boots, one large nut, and a large lock washer from the threaded end of the shifter cable. Slide the end of the cable into the cable bracket. Install the large nut and the lockwasher loosely over the end of the cable. Install the two rubber boots onto the end of the cable. Install the swivel on the threaded end of the cable and position it in the center of the threaded portion.

13. Move the transmission selector lever by hand to the full rear position (Low). Operate the shifter lever to the Low gear position (ratcheted all the way back). Adjust the large nuts on the cable so that the swivel will slide into the **front** hole on the selector lever. Tighten the large nuts completely. Be sure that the swivel will slide freely in and out of the hole in the selector lever.

**Note: The shifter will not operate correctly unless the front hole in the shift lever is used.**

Leave the swivel out of the hole and move the selector lever to Park, all the way forward. Also move the shifter to the Park position (all the way forward). Reinsert the swivel into the **front** hole in the selector lever. Check to see that the swivel will slide freely in and out of the **front** hole in the selector lever in this position. If it does not slip in freely, adjust the swivel slightly until it will slip into the hole in the lever.

Move the shifter back to the Low gear position and check that the swivel will still slide easily in and out of the **front** hole in the selector lever. (If you do not use the **front** hole in the lever, it will be impossible to correctly adjust the cable.) Operate the shifter through all the gear positions. Check to make sure the swivel will slide in and out of the **front** selector lever hole in each gear position. The shift cable is now correctly adjusted. Install the cotter key supplied with the shifter into the swivel and spread the key ends.

If you have a problem, **DO NOT FORCE THE SHIFTER**, this will damage the cable, the shifter or the transmission. Simply start at the beginning and carefully check all your steps.

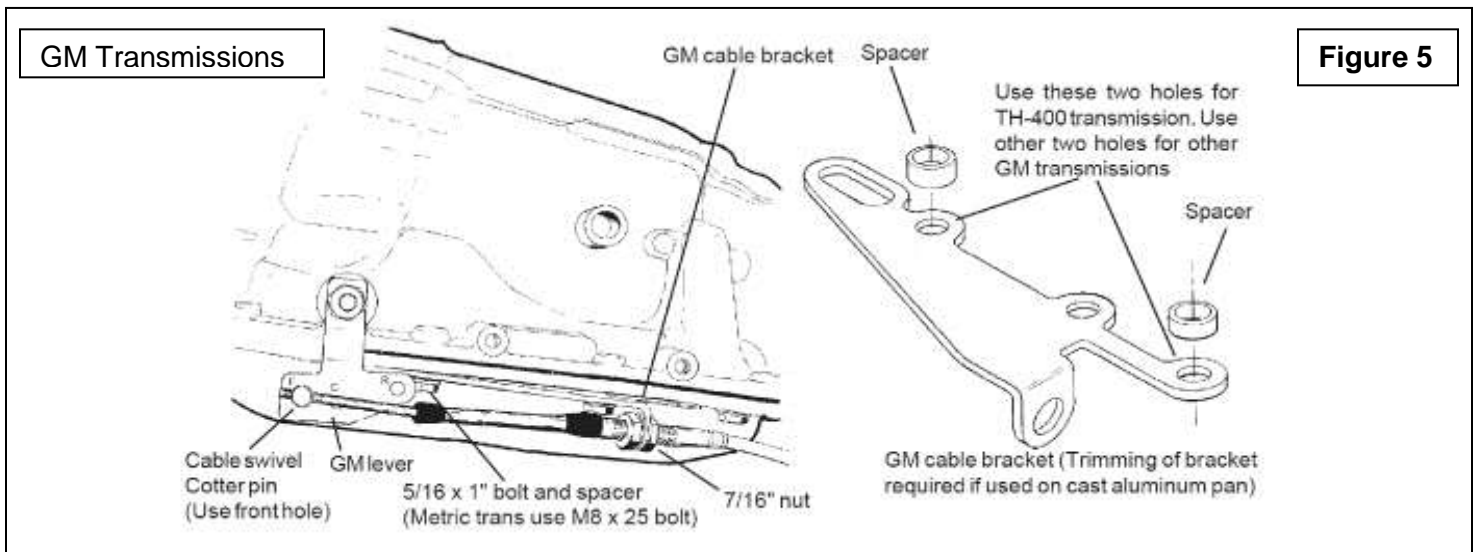

14. On GM vehicles, the neutral safety switch may be located on the shifter (steering column or console), or it may be a mechanical interlock in the steering column that prevents the key from turning to the Start position unless the shifter is in the Park or Neutral position. Identify the type of neutral safety system you have. If the key will not turn to the Start position unless the stock shifter is in Park or Neutral, you have a mechanical interlock type, otherwise you have a neutral safety switch type. If you have a neutral safety switch, locate the switch and identify the neutral safety wires (engine will not crank unless these wires are connected together). With either type, disconnect the battery ground cable to prevent accidental shorts. If you have a neutral safety switch, disconnect and extend both wires from the GM switch to the switch on the shifter. If you have a mechanical interlock cut the wire that goes from the start position on the ignition switch to the solenoid on the starter. This wire is usually a 10 or 12 gauge purple wire. Run wires from both ends of the cut wire to the switch on the shifter. Put slip on terminals on the ends of the lengthened wire. Crimp the terminals onto the wires using a crimping tool or pliers. Connect the wires to the **LOWER** switch on the shifter. Identify the wires for the backup lights and run them to the **UPPER** switch on the shifter. Tape the terminal connections and all other connections to prevent shorts. Reconnect the battery ground cable, disconnect the coil wire and set the parking brake. Check the switch operation by attempting to start the motor in each shifter position. **The starter must crank only when the shifter is in the Park or Neutral position.** Adjust the switches if required. Reconnect the coil wire. Go to **Step 27**.

## FORD

15. If you have not already done so, remove the nut and the lockwasher holding the downshift linkage onto the downshift lever shaft. The downshift lever is the outer lever on C-4, C-5, C-6 and AOD transmissions. Pull the lever off the shaft and allow the linkage to hang free. Remove and discard the stock shift linkage rods. Some C-6 and all (late) C-4 and C-5 transmissions have a neutral safety/backup light switch on the transmission shift lever. If your transmission is so equipped, remove the two bolts holding the switch in place and slide it off the shift shaft. Disconnect the switch at the factory plug and discard it.

16. Install the Hurst selector lever (See Figure 6 or 7). Note: The Hurst lever must point downward for proper operation. If the stock shift lever on your transmission points down, you will have to remove the lower part of the stock arm by cutting it off to clear the Hurst lever (See Figure 6 ). Install the Hurst selector lever onto the shift shaft of the transmission. Align the selector lever so when it points straight down it travels equal arcs in both directions from the center, then tighten the 1/4"- 20 x 1 1/2" pinch bolt and nut. The lever should travel smoothly from front to back with a positive click in each gear position. Make sure the O-ring is in position on the downshift shaft and install the downshift lever in position on the shaft. Install the lockwasher and the nut and tighten securely. The downshift lever must operate smoothly. Reconnect the downshift linkage.

17. Cable bracket installation: **AOD:** Instructions for the AOD are included with the optional installation kit, Part No. 40496. **C-4, C-5:** Remove the two lower bolts from the rear servo cover. Install the cable bracket in position (See Figure 6). Install the two servo cover bolts as removed and tighten to 12-13 lb.ft. Do not overtighten as this can distort the servo cover. **C-6:** Remove the two transmission oil pan bolts from the left rear corner of the oil pan. Install the cable bracket in position with the two spacers between the pan and the bracket (See Figure 7). (If your transmission is

equipped with a cast aluminum oil pan, these spacers can be omitted.) Install the two 5/16-18 x 1.00" bolts supplied and tighten to 12-13 lb.ft. Do not overtighten as this can damage the pan gasket.

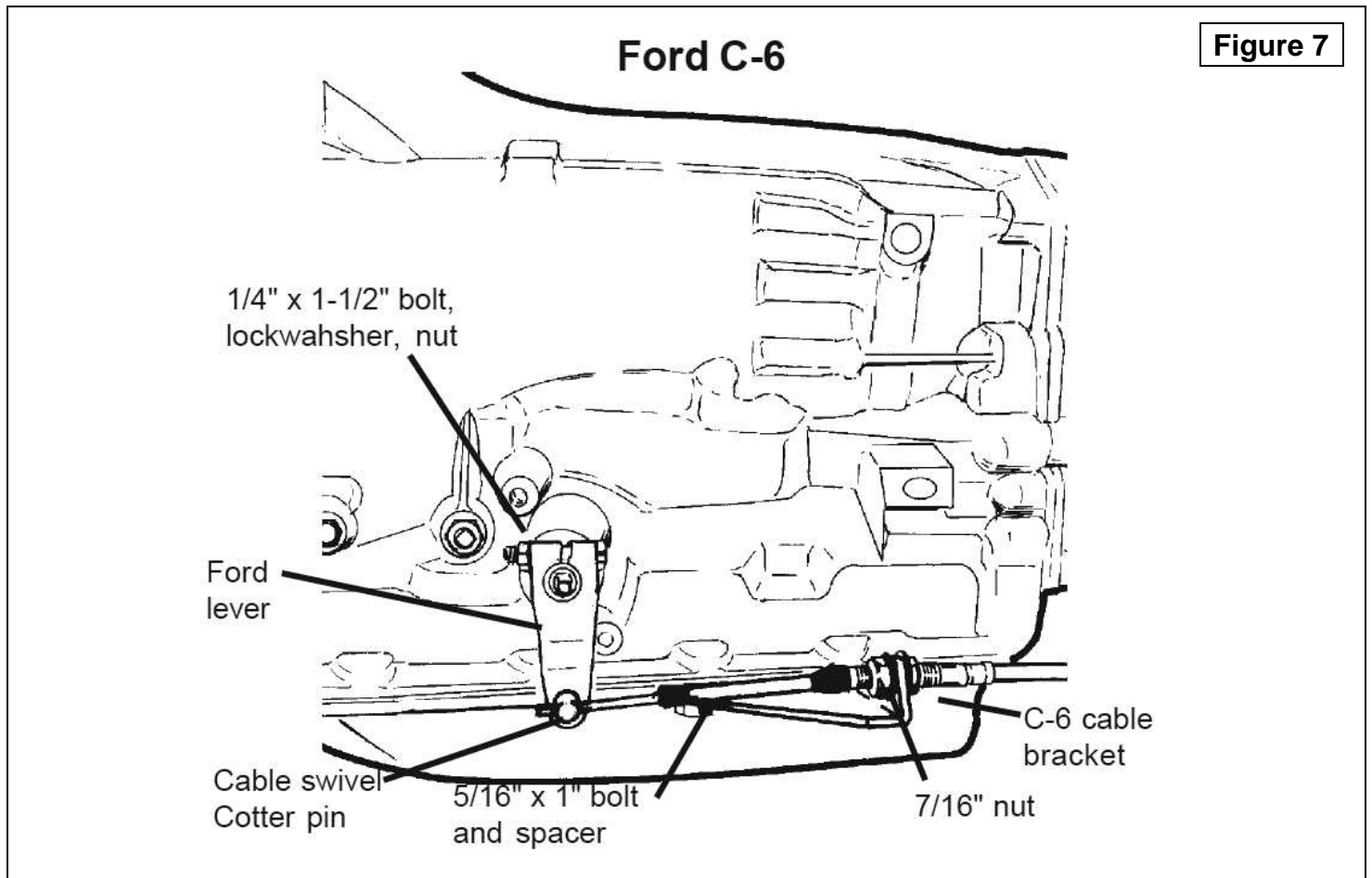
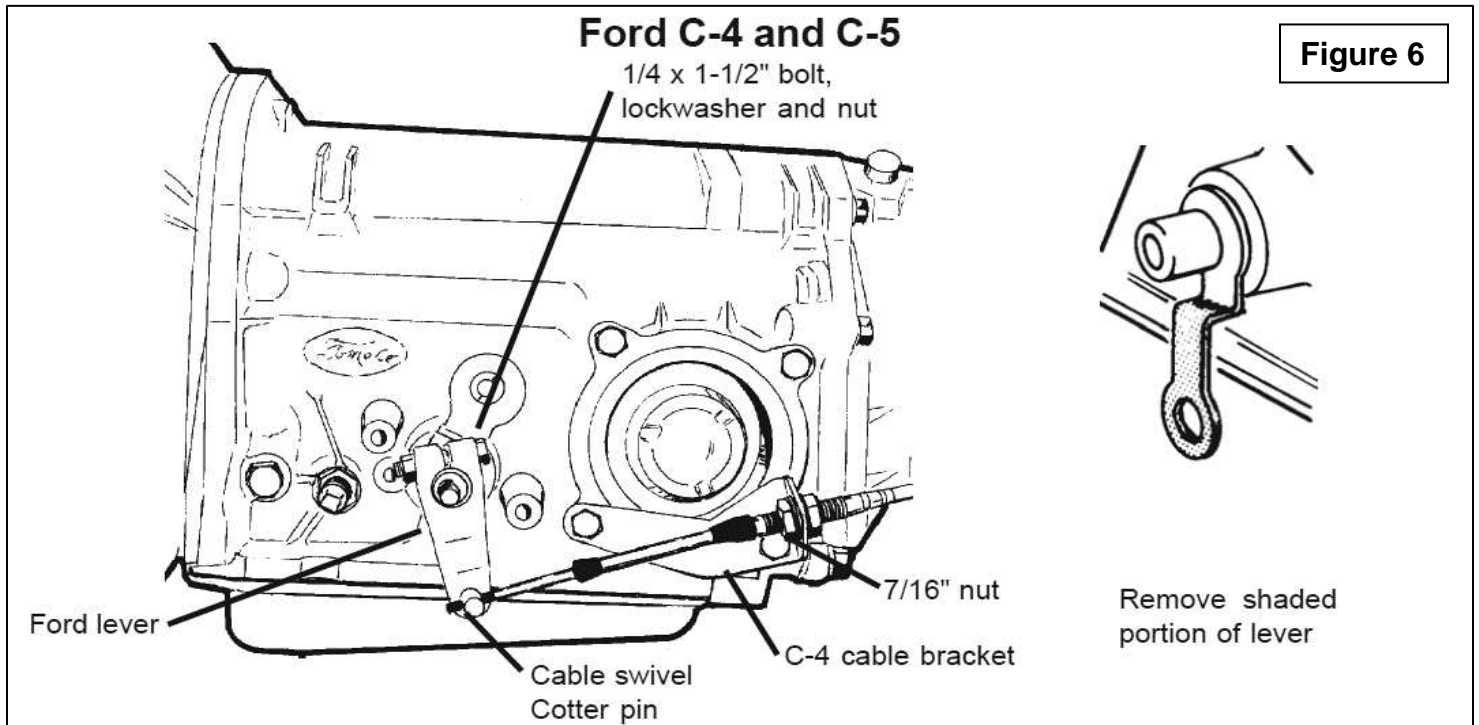

18. Route the shifter cable according to Figure 4. Avoid kinks and sharp bends and route the cable away from hot engine or exhaust parts. Remove the two rubber boots, one large nut, and a large lockwasher from the threaded end of the shifter cable. Slide the end of the cable into the cable bracket. Install the large nut and the lockwasher loosely over the end of the cable. Install the two rubber boots onto the end of the cable. Install the swivel on the threaded end of the cable and position it in the center of the threaded portion.

19. Move the transmission selector lever by hand to the full rear position (Low). Place the shifter lever to the Low gear position (ratcheted all the way back). Adjust the large nuts on the cable so that the swivel will slide into the hole on the selector lever. Tighten the large nuts completely. Be sure that the swivel will slide freely in and out of the hole in the selector lever.

With the swivel in the selector lever, move the shifter to the Park position, as far forward as the shifter will go without forcing it. (The shifter has further travel that is used to reach the GM Park position but is not used on the Ford transmissions. Trying to force the cable will damage the cable.) The shift lever on the transmission should be all the way forward. Check to see that the swivel will slide freely in and out of the hole in the lever in this position. If it does not slip in freely, adjust the swivel slightly until it will slip into the hole in the lever in both the Low and Park positions. Operate the shifter through all the gear positions. Check to make sure the swivel will slide in and out of the selector lever hole in each gear position. Install the cotter key supplied with the shifter into the swivel and spread the key ends.

If you have a problem, **DO NOT FORCE THE SHIFTER**, this will damage the cable, the shifter or the transmission. Simply start at the beginning and carefully check all your steps.

**IMPORTANT:** Do not force the shifter to over travel into the Park position. This will move the shifter into GM Park position and will damage the cable or the transmission.

20. On Ford vehicles, the neutral safety/backup light switch is located on the transmission (or on the steering column on some early vehicles). If the vehicle has an AOD transmission the neutral safety/backup light switches on the Hurst shifter will NOT be used. The neutral safety/backup light switch on the AOD transmissions will continue to function normally. On the C-4 and C-5 transmissions, it is necessary to completely remove the stock neutral safety/backup light switch in order to install the Hurst transmission shift lever. On C-4, C-5 and C-6 transmissions, it will be necessary to hook up the neutral safety/backup light switches on the Hurst Vmatic3 shifter. Locate and identify the neutral safety (the engine will not crank unless these wires are connected together), and reverse light wires. Disconnect the battery ground cable before beginning to wire the neutral safety and the reverse light switches. Reroute the wires to the Hurst Vmatic3 shifter. Strip 1/4" of insulation off the wires and install the supplied slip-on terminals. Crimp the terminals onto the wires using a crimping tool or pliers. Connect the neutral safety wires to the **LOWER** switch and the reverse light wires to the **UPPER** switch (See Figure 1). Tape the terminal connections to prevent shorts. Reconnect the battery ground cable, disconnect the coil wire and set the parking brake. Check the switch operation by attempting to start the motor in each shifter position.

**The starter must crank only when the shifter is in the Park or Neutral position.** Check the backup light operation when the shifter is shifted to the Reverse position. Adjust the switches if required. Reconnect the coil wire. Go to **Step 27**.

## CHRYSLER

21. If you have not already done so, loosen the pinch bolt on the throttle lever on the transmission. This is the lever on the small diameter shaft. Pry the lever off with a screwdriver and allow the linkage to hang free. Remove and discard the stock shift lever and the stock shift linkage. Install the Hurst selector lever in position and tighten the pinch bolt securely (See Figure 8). Make sure the lever is not pushed down so far as to touching the transmission case. This will cause the lever to bind on the case. The lever should travel smoothly from front to back with a positive click in each gear position. Install the stock throttle lever in position on the small diameter shaft as removed and tighten the pinch bolt securely. The throttle lever must operate smoothly.

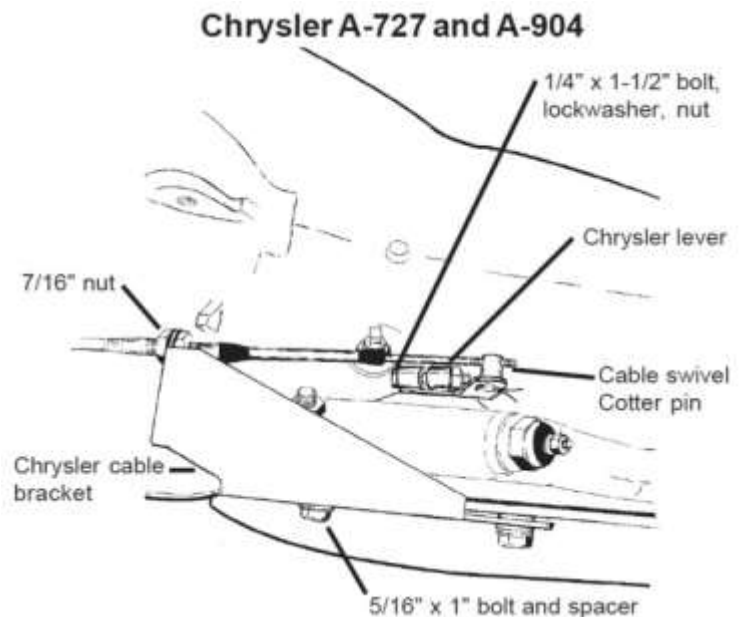

22. Remove the two transmission oil pan bolts directly below the shift lever. Install the cable bracket in position with the two spacers between the pan and the bracket (See Figure 8). (If your transmission is equipped with a cast aluminum oil pan these spacers can be omitted.) Install the two 5/16-18 x 1.00" pan bolts supplied and tighten to 12-13ft/lb. Do not overtighten as this can damage the pan gasket.

23. Route the shifter cable according to Figure 4. Avoid kinks and sharp bends and route the cable away from hot engine or exhaust parts. Remove the two rubber boots, one large nut, and a large lockwasher from the threaded end of the shifter cable. Slide the end of the cable into the cable bracket. Install the large nut and the lockwasher loosely over the end of the cable. Install the two rubber boots onto the end of the cable. Install the swivel on the threaded end of the cable and position it in the center of the threaded portion.

24. Move the transmission selector lever by hand to full forward position (Low). Place the shifter lever to the Low gear position (ratcheted all the way back). Adjust the large nuts on the cable so that the swivel will slide into the hole on the selector lever. Tighten the large nuts completely. Be sure that the swivel will slide freely in and out of the hole in the selector lever.



With the swivel in the selector lever, move the shifter to the Park position, as far forward as the shifter will go without forcing it. (The shifter has further travel that is used to reach the GM Park position but is not used on the Chrysler transmissions. Trying to force the shifter will damage the cable.) The shift lever on the transmission should be all the way back. Check to see that the swivel will slide freely in and out of the hole in the lever in this position. If it does not slip in freely, adjust the swivel slightly until it will slip into the hole in the lever in both the Low and the Park positions. Operate the shifter through all the gear positions. Check to make sure the swivel will slide in and out of the selector lever hole in each gear position. Install the cotter key supplied with the shifter into the swivel and spread the key ends.

If you have a problem, **DO NOT FORCE THE SHIFTER**, this will damage the cable, the shifter or the transmission. Simply start at the beginning and carefully check all your steps.

**IMPORTANT:** Do not force the shifter to over travel into the Park position. This will move the shifter into GM Park position and will damage the cable or the transmission.

25. Check the operation of the throttle linkage again. The linkage must operate smoothly with no bind. All the transmissions using automatic valve bodies must have the throttle linkage connected and operating, or transmission damage will result.

26. Neutral safety/backup light switch.

'66-'68: The neutral safety switch will continue to function normally. It will not be necessary to hook up the neutral safety switch wires on the shifter. Disconnect the battery ground cable before wiring the backup light switch. Locate the original backup light switch on the steering column or the console shifter. Run these wires to the top switch on the Hurst Vmatic3 shifter (See Figure 1). Reconnect the ground wire and check the light for proper operation. Adjust the switches on the shifter if required.

'69 and Later: The neutral safety/backup switch is located on the transmission and will continue to function normally. It will not be necessary to connect any wires to the switches on the shifter.

27. Place the tower over the shifter mechanism until the bottom edge of the tower touches the floor. Put the shifter cover and the indicator cable through the opening in the top of the tower. Hold the tower level to the shifter with the bottom of the tower touching the highest surface on the floor it will come into contact with (See Figure 9). Use a ruler to measure the distance X from the underside of the tower to the tower mounting brackets on the shifter mechanism.

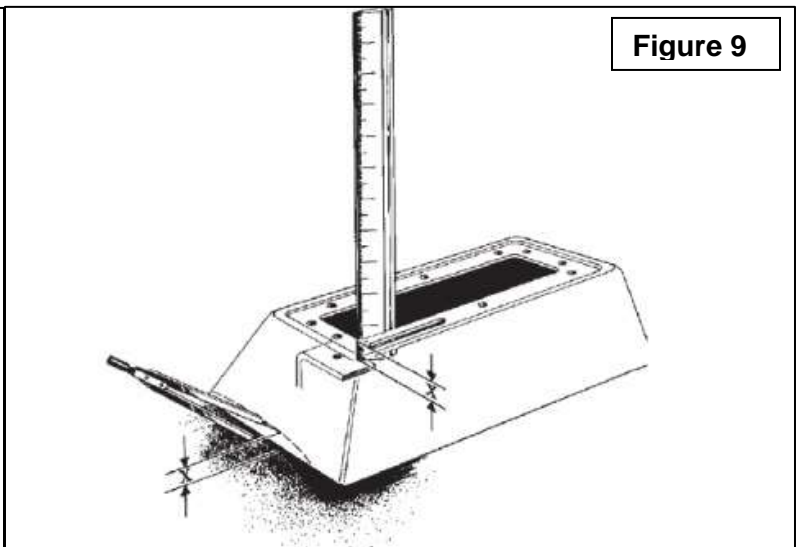

## IMPORTANT

Before installing the T-handle onto the shifter, put Loctite on the threads of the stick. The aluminum of the T-handle may gall on the threads of the stick and make it impossible to remove the T-handle from the stick. If this occurs it can cause the stick to break if you use excessive force while attempting to remove the T-handle from the stick.

28. Set a pair of dividers at the distance X, measured in step 27. Hold the tower level to the shifter mechanism with the bottom of the tower touching the highest surface on the floor it will come into contact with. Holding the tower in position, place one leg of the divider against the floor while the other touches the tower (See Figure 9). Using the dividers, scribe a line around the tower that follows the contour of the floorboard. Remove the tower and trim at the scribe line using tin snips. Once the tower is properly trimmed, install it using two flat head sheet metal screws. The indicator cable should be routed out the top of the tower on the right side while the tower is being installed.

29. Install the indicator light bulb in its socket on the shifter cover plate. Run a length of wire from the vehicle's instrument light circuit to one of the wires. Connect the other wire to a good chassis ground. A shifter mounting bolt should be satisfactory.

30. Snap the shift position window into the cover plate. The window snaps in from the top with tabs inserting into slots at either end of the window opening. Place the shifter in the Park position then remove the T-Handle from shifter. Place the cover plate over the stick and onto the top of the tower. Route the indicator cable as shown in Figure 10. (If the cable is not routed this way, the indicator may bind.) Run the shifter through all of the gears to check the operation of the indicator. If the indicator needs adjustment, loosen the screws holding the indicator cable clamp to the cover plate and slide the cable bracket to adjust the indicator position. (Retighten these screws carefully since they are threaded into plastic.) Attach the cover plate to the tower with four Phillips head screws.

Route indicator cable around front of backing plate and over top of shift cable

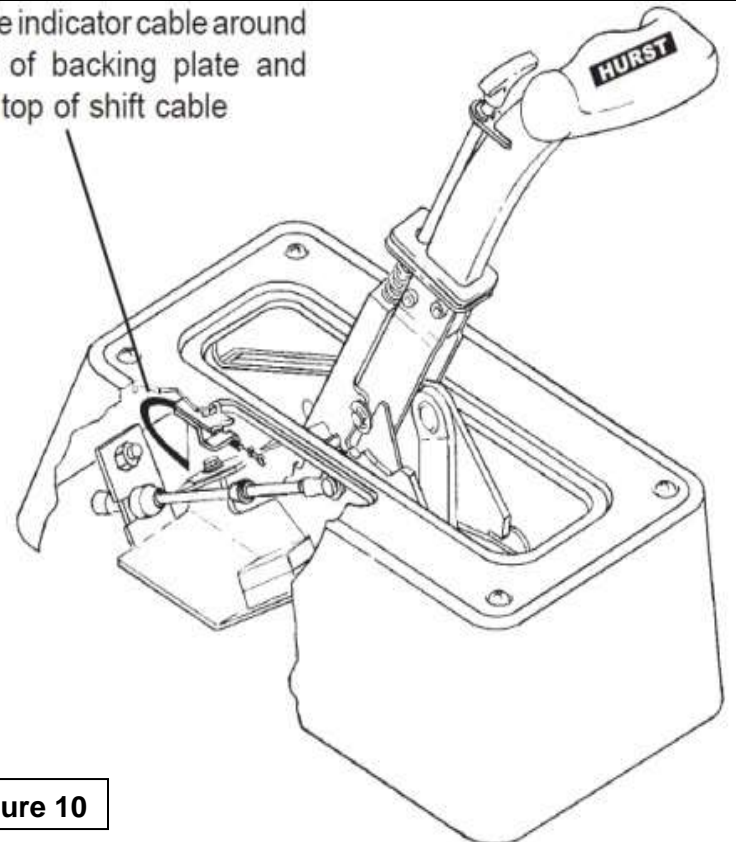

Figure 10

31. Slide the boot over the stick and install it into the cover plate. After the boot is installed in the cover plate and into the stick, install the T-Handle and the jam nut. Tighten the jam nut when the handle is properly oriented.

## OPERATION

The Hurst Vmatic3 shifter normally functions as a straight gate detent shifter from Park to Reverse to Neutral to Drive and as a ratchet shifter from Neutral to all forward gears. Refer to the following instructions for proper operation:

**STRAIGHT GATE MODE:** With the trigger in the upper position, the shifter functions in the STRAIGHT GATE mode. The handle travels in a direct line forward and backward from Park to Drive. The trigger must be raised up to clear the stop gates while going through the gear positions.

**RATCHET SHIFT MODE:** The RATCHET SHIFT mode allows firm, positive no-miss upshifts and downshifts through all the positions from 1 (Low gear) to Neutral. To switch from STRAIGHT GATE to RATCHET operation, first operate shifter to the Drive position. The trigger will snap down approximately 3/4". The shifter is now in the RATCHET MODE, Drive gear position. The shifter will only operate in the RATCHET MODE between Neutral and First, it will not ratchet to Reverse or Park. This is done to prevent accidental shifting into Reverse.

### SHIFTING IN THE RATCHET MODE:

Move the shift handle forward or backward with a quick firm action until it hits the internal stops, and allow it to spring return to the center position. The shifter is now ready for the next shift. To switch the shifter from RATCHET MODE back to the STRAIGHT GATE MODE, operate the shifter to the Drive gear position, pull up firmly on the trigger to engage the STRAIGHT GATE MODE and move the handle forward to Neutral, Reverse and Park.

**REMEMBER:** To switch from the STRAIGHT GATE MODE to the RATCHET MODE or from RATCHET MODE to STRAIGHT GATE MODE you must be in the Drive gear position. Refer to the shift indicator gear position.

**SPECIAL NOTE:** If the instructions for operating your shifter seem complicated, DO NOT BECOME ALARMED. You will find that in actual use the shifter will be extremely easy to operate after a minimal amount of experience. Caution: The shifter is an important controlling mechanism of your vehicle and can create serious driving hazards when any part is loose, missing or mis-adjusted. After you have installed your Hurst Vmatic3 shifter in the vehicle, we recommend you review the instructions to assure complete and proper installation.

## CHECKLIST

- \_\_\_ Locking steering column lever is permanently fastened in the full up position. Step 2.
- \_\_\_ Shifter is convenient to reach and has ample room for your hand in both park and low gear. Step 3.
- \_\_\_ Carpet covers floorboard holes. Step 5.
- \_\_\_ Cable is securely fastened to the shifter and held with cotter pin. Step 7
- \_\_\_ Shifter is securely mounted to floorboard. Step 8.
- \_\_\_ Shifter cable is clear of exhaust system, engine and any moving parts. Step 8.
- \_\_\_ Throttle lever and shift lever are tight on transmission. GM step 10, Ford Step 15, Chrysler Step 21.
- \_\_\_ Oil pan bolts are tightened to 12-13 lb.ft. GM Step 11, Ford Step 17, Chrysler Step 22.
- \_\_\_ Shifter is properly adjusted. Cable boots are installed, cable nuts are tightened and swivel is secured with cotter key. GM Step 13, Ford Step 19, Chrysler Step 24.
- \_\_\_ The Neutral safety and Reverse light switches are connected and properly adjusted to prevent engine starts in drive gears and Reverse. GM Step 14, Ford Step 20, Chry Step 26.
- \_\_\_ There is no debris in the shifter mechanism.
- \_\_\_ Tower is trimmed and securely held with two screws. Step 27.
- \_\_\_ Cover installed and shift position indicator operating properly. Step 29.
- \_\_\_ Shifter moves freely in all positions as described in Shifter Operation.
- \_\_\_ If your shifter is not working properly do not attempt to drive your car. Make sure you have followed all instructions. If the shifter is broken or defective return it to your **Hurst** dealer.

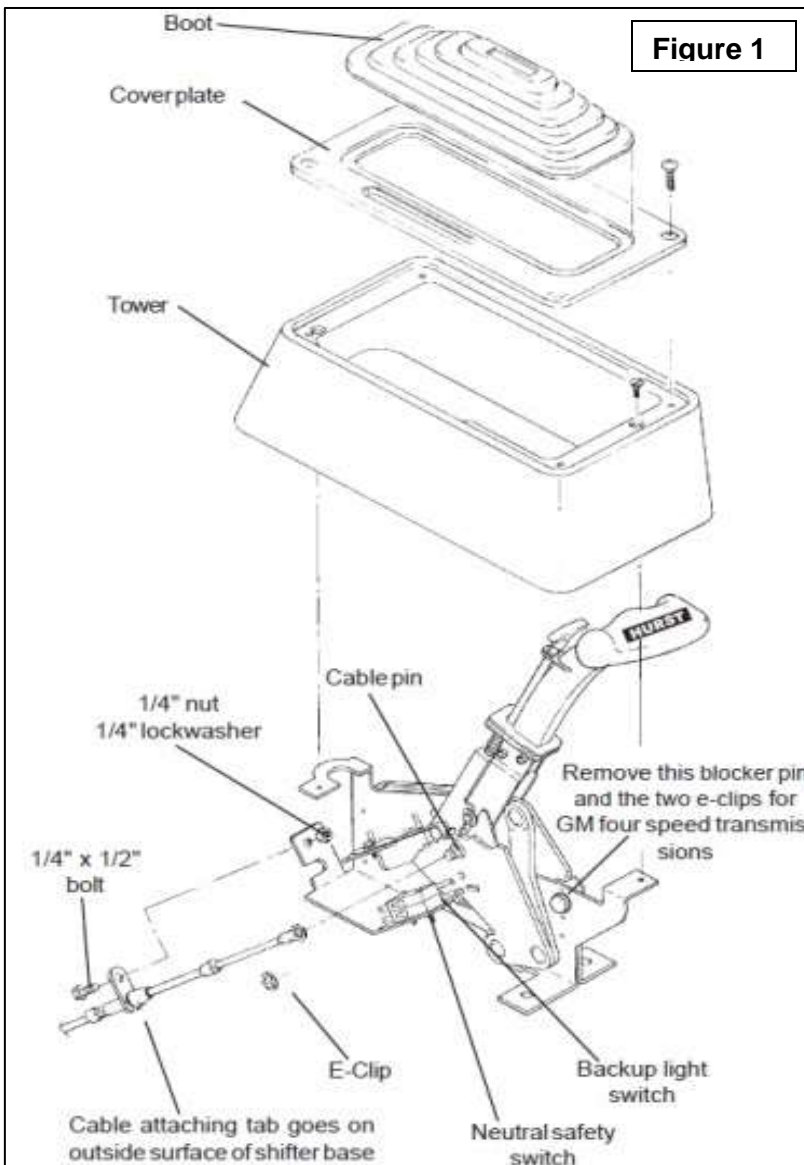

**Figure 1**

- TOOL LIST**
- 1 Common screwdriver
  - 1 Phillips screwdriver
  - 1 1/4" wrench or socket
  - 2 7/16" wrench or socket
  - 1 1/2" wrench
  - 2 11/16" wrench
  - 1 13mm wrench  
(Metric transmissions)
  - 1 Drill motor
  - 1 9/32" drill bit
  - 1 1/2" drill bit or holesaw
  - 1 0-50 lb.ft. torque wrench
  - 1 File
  - 1 Tin snips
  - 1 Hack saw
  - 1 Wire stripper
  - 1 Wire crimper
  - 1 Pliers
  - 1 Ruler
  - 1 Dividers
  - A/R Electrical tape
  - A/R Tie wraps  
(to secure cable)
  - 2/4 Jack stands

**IMPORTANT: RETAIN THESE INSTRUCTIONS FOR FUTURE REFERENCE**

**Technical Service**

A highly trained technical service department is maintained by Hurst Performance to answer your technical questions, provide additional product information and offer various recommendations.

Technical service calls, correspondence, and warranty questions should be directed to:



**Hurst Performance Products**

(707) 544-4761

[www.Hurst-Shifters.com](http://www.Hurst-Shifters.com)