



## Installation Instructions

### HURST COMPETITION AND BILLET/PLUS SHIFTER

2005-2010 Mustang w/5-speed Manual Transmission (GT only)

Catalog# 3910201

**WORK SAFELY!** For maximum safety, perform this installation on a clean, level surface and with the engine turned off. Place blocks or wedges in front of and behind both rear wheels to prevent movement in either direction.

**CAUTION:** To avoid any possibility of bodily injury or damage to vehicle, do not attempt installation until you are confident that the vehicle is safely secured and will not move.

**NOTE:** FOR PHOTOGRAPHIC PURPOSES, A 2010 MUSTANG IS SHOWN THROUGHOUT THESE INSTRUCTIONS. 2005-2009 GT KITS INSTALL WITH IDENTICAL STEPS.

#### PARTS



Knob



Knob Nut



Hurst Stick



Shifter (3915201 shown)



Stick Mounting  
Screws (2)



Stick Mounting  
Washers (2)

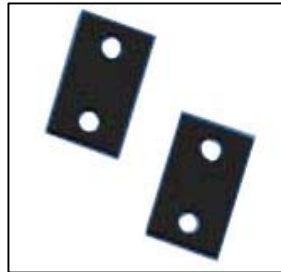

Neoprene  
Isolators (2)

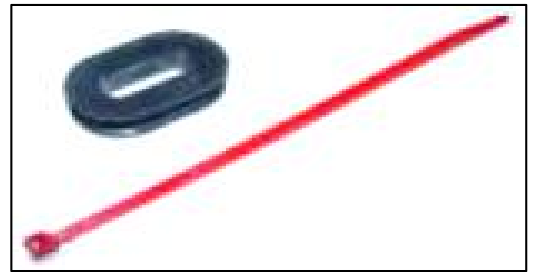

Boot Support and Zip Tie

## TOOLS



Flat Blade  
Screwdriver



Plastic Trim  
Tool

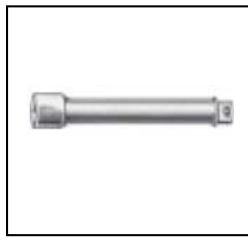

Extension

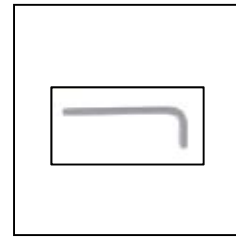

7/32" Hex  
Wrench



Ratchet



10mm, 13mm,  
9/16" Wrench



10mm Deep  
Socket

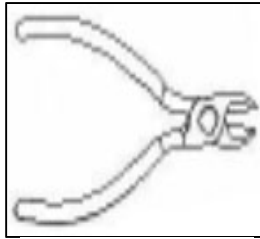

Cutting Pliers



Floor Jack



Jack Stands

**STEP 1.** Move the shift knob to the Neutral position. (Set the parking brake to ensure that the vehicle does not move during installation).

**2005-2009:** Work the upper part of the shift boot out of the retainer groove of the shift knob and slide down onto stick.

**2005-2010:** Remove the knob by turning counter clockwise.



**STEP 2.** Remove the shifter boot.

**2005-2009:** Place fingers or Trim Tool underneath outer corners of the shifter boot and pull up to unsnap from the center console. Slide boot up and over the shift stick and place the boot aside. Skip to STEP 5.

TOOL: Plastic Trim Tool

**2010:** See STEP 3.



**STEP 3. 2010 MUSTANGS ONLY:**

Open the rear storage compartment cover on the center console. Firmly grab the upper center console and pull upward to unsnap from the lower center console. (Opening the cup holder cover may facilitate removal of the top center console piece).



**STEP 4. 2010 MUSTANGS ONLY:**

Disconnect the ESC/Hazard/Trunk Release harness from the bottom of the center console. Remove the center console and set aside.



**STEP 5.** Remove rubber dust boot from shift stick by pulling up and out of the floor pan opening and sliding it over the shift stick. Set boot aside.



**STEP 6.** Carefully raise vehicle for under car access.

TOOL: Floor Jack and Jack Stands

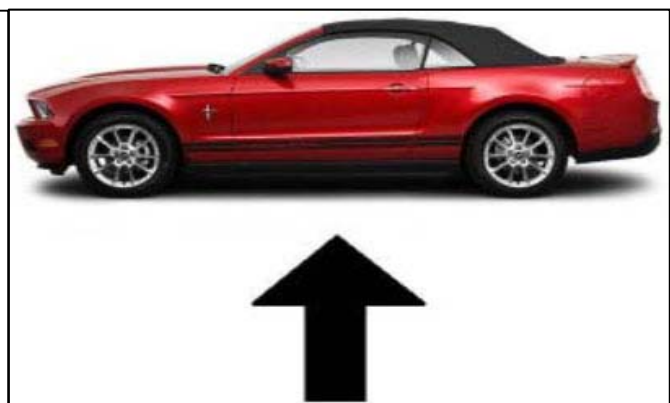

**STEP 7.** Remove the hex nut that secures the transmission linkage rod to the bottom of the shifter and set aside.

TOOL: 13mm Wrench



**STEP 8.** Remove the transmission linkage rod by pulling it out of the stock shifter.



**STEP 9.** Remove the front bolt that attaches the shifter assembly arm to the transmission and set aside.

TOOL: 10mm Wrench



**STEP 10.** Remove the two (2) hex nuts that secure the rear mount of the shifter assembly to the floor and set aside.

TOOL: 10mm Deep Socket, Ratchet, Extension



**STEP 11.** Remove the metal bracket from the rear rubber mount and set aside.

**NOTE:** Some Mustangs may contain a clip on one or both of the studs making the bracket difficult to remove. Carefully remove the bracket by working it from side to side until it is removed. **DO NOT** force the bracket off the studs by pulling it down as these clips can damage the threads.

(The picture shows a bracket with only one (1) clip that has been moved out of the way instead of being removed.)



### Assembly

**STEP 12.** Remove the stock shifter from the vehicle. One method is to move the entire shifter assembly down so that just the top part of the stick is inside the vehicle. Then move the shifter assembly forward enough so that the tail end of the shifter can be pushed upwards through the tunnel opening. Once the tail end is through the opening, the shifter can be removed from the inside of the vehicle.



**STEP 13.** Place the factory shifter on a workbench and remove the two (2) metal flanged sleeves from the front rubber bushings on the shifter assembly arm.

**TOOL:** Flat Head Screwdriver



**STEP 14.** Remove the two (2) plastic bushings from the bottom of the shifter. These bushings should be removed by hand to not damage them.



**STEP 15.** Place the HURST shifter on a workbench and insert the two (2) metal flanged sleeves into the bushings in the HURST shifter assembly arm.



**STEP 16.** Insert the two (2) plastic bushings into the bottom of the HURST shifter.



**STEP 17.** From the inside of the vehicle, carefully insert the HURST shifter assembly through the console and into the opening in the floor tunnel. If you can push the tail end of the shifter assembly down into the tunnel from the inside, you should do so. If not, this can be done from underneath the vehicle.

**NOTE:** The ridges on the upper stick must face towards the passenger's side.



**STEP 18.** From underneath the vehicle, work the HURST shifter assembly forward so that the tail end can go through the tunnel opening. (Follow guidelines given in STEP 12). Then attach the front shifter arm to the transmission and insert the hex bolt removed in STEP 9 but do not tighten at this time.

TOOL: 10mm Wrench



**STEP 19.** Attach the metal bracket to the rear urethane mount on the HURST shifter assembly and align the holes in the bracket with the two (2) threaded studs on the vehicle. Replace the two (2) hex nuts removed in STEP 10 and tighten securely.

TOOL: 10mm Deep Socket, Ratchet, Extension

NOTE: Make sure the metal bracket “hugs” the urethane mount and sits in its groove. The urethane mount may need to be moved forward or back to align with the bracket and the studs. DO NOT over tighten the hex nuts. Excessive force can break the studs.



**STEP 20.** Tighten the hex bolt from STEP 18 that secures the shifter arm to the transmission. Insert the transmission linkage rod into the bushings at the bottom of the HURST shifter. Replace the hex nut removed in STEP 7 and tighten securely.

TOOL: 10mm Wrench, 13mm Wrench

NOTE: Offset (long side) of connector located on stick bottom must face towards the driver's side. If the serrations on the lower stick are facing the passenger side, then the connector is in the correct orientation.

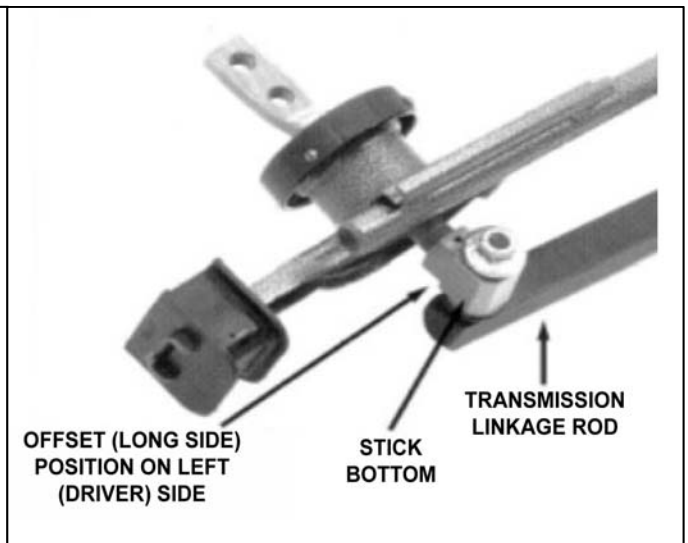

**STEP 21.** Carefully lower vehicle. From inside the vehicle, attach the HURST upper stick to the lower stick with two (2) stick mounting washers and two (2) stick mounting screws and tighten.

TOOL: 7/32 Hex Wrench (Allen Key)



**STEP 22. OPTIONAL: ISOLATOR INSTALLATION**

The provided neoprene isolators can be installed to help reduce some of the transmission noise that may be transmitted through the shifter stick. Install one or both of the isolators between the lower stick and the upper stick. Attach using two (2) washers and two (2) screws and tighten.

NOTE: The isolators may not eliminate ALL transmission noise or vibration and may reduce shift feel and overall strength of the system.



**STEP 23.** Reinstall the rubber boot that was removed in STEP 5. Push down the lower lip of the boot through the vehicle's tunnel to ensure a proper seal. With the boot in place, test the shifter operation. Move shifter through all the gears and make sure that it engages each gear fully and that the stick moves freely from side to side in the Neutral position. The knob may be temporary installed to aid in testing.





**STEP 24.** Push the rubber boot support onto the HURST chrome stick.



**STEP 25.** Replace the shifter boot that was removed in STEP 2.

**2005-2009:** Slide the boot over the HURST chrome stick. Position the boot correctly and carefully press down around the outer edges until the retainer clips snap firmly into place. Work the boot into the groove of the rubber boot support. Skip to STEP 31.

**2010:** See STEP 26



**STEP 26. 2010 MUSTANGS ONLY:**

Remove the boot material from the plastic retainer.

**NOTE:** The boot material is attached to the plastic retainer with a strong adhesive. Slowly pull on the boot to remove from retainer. Slight tearing of the boot may occur. Alternatively, you can use scissors or a blade to cut the boot free from the retainer.

**TOOL:** (Optional) Scissors or a blade.



**STEP 27. 2010 MUSTANGS ONLY:**

Place the upper center console loosely over the lower center console. Arrange the upper center console in a way that will give you some working room between both consoles. Slide the boot over the HURST chrome stick.



**STEP 28. 2010 MUSTANGS ONLY:**

Work the boot over the rubber boot support. Make sure the boot material is properly orientated and attach a zip tie around the boot material. Make sure the zip tie is in the groove of the rubber boot support and tighten. Cut off the excess zip tie material.

TOOL: Cutting pliers



**STEP 29. 2010 MUSTANGS ONLY:**

Reconnect the ESC/Hazard/Trunk Release harness that was disconnected in STEP 4.



**STEP 30. 2010 MUSTANGS ONLY:**

Replace upper center console to lower center console by snapping into place.



**STEP 31.** Attach the Knob Nut onto the HURST stick and thread down as far as possible without forcing it.



**STEP 32.** Screw on the HURST knob all the way down until it contacts the knob nut, then back it off until the orientation of the shift pattern/logo is correct.



**STEP 33.** With one hand holding the knob in the correct orientation, use the other hand to tighten the knob nut up against the knob.

TOOL: 9/16" Wrench



**STEP 34.** Congratulations. You have now installed HURST's short throw shifter in your Mustang.



**IMPORTANT: RETAIN THESE INSTRUCTIONS FOR FUTURE REFERENCE**

**Technical Service**

A highly trained technical service department is maintained by Hurst Performance to answer your technical questions, provide additional product information and offer various recommendations.

Technical service calls, correspondence, and warranty questions should be directed to:



**Hurst Performance Products**

(707) 544-4761

[www.Hurst-Shifters.com](http://www.Hurst-Shifters.com)