



Installation Instructions

HURST BILLET COMPETITION/PLUS SHIFTER

2009-2018 Dodge Challenger

Catalog #3916120

WORK SAFELY! For maximum safety, perform this installation on a clean, level surface and with the engine turned off. Place blocks or wedges in front of and behind both rear wheels to prevent movement in either direction.

CAUTION: To avoid any possibility of bodily injury or damage to vehicle, do not attempt installation until you are confident that the vehicle is safely secured and will not move.

IMPORTANT

This shifter has been primarily designed as a “competition” and/or “race” shifter. As such, much of the isolation has been reduced to give the driver the most direct and positive link to the transmission without compromise. In doing so, this does increase both tactile and sometimes audible levels of vibration. While every effort has been made to reduce the amount of objectionable transmission/driveline noise transmitted into the interior of the vehicle, some vehicles may experience greater amounts than others.

PARTS



Shifter



Stick



Boot Support & Set Screw



Button Head Screws & Lock Washers

TOOLS



**7mm, 8mm, 10mm
13mm Socket**



Wrench & Hex Wrench

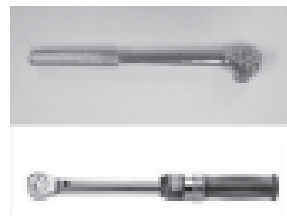

Ratchet & Torque Wrench

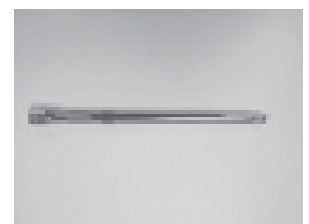

Long Extension



Phillips Screwdriver



Flat Blade Screwdriver



Jack Stands (Optional)



Floor Jack (Optional)

DISASSEMBLY

1. Carefully unsnap the boot bezel from the center console (2009-2014 MY shown).

NOTE: 15-16 MY vehicles - unsnap boot only. The bezel does not unsnap.



2. Unbolt the upper stick assembly from the shifter and remove knob, boot, stick assembly.

TOOL: 1/2" Wrench



3. Carefully unsnap the center console trim/cup-holder plate from the center console.

NOTE: 15-16 MY and newer console design (1) is different than pre-2015 MY vehicles and will require disconnection of wiring to center controls.



2014MY and Earlier



2015MY and Later

4. Disconnect the 12V accessory / cigarette lighter socket wiring harness connection and small USB connector (if so equipped) in front of center console opening. For '15 and newer, disconnect the USB and main harness connector.

NOTE: The 12V accessory / lighter socket is part of the center console on 2015MY and newer models and will not be necessary to disconnect.



5. Disconnect the cup-holder lighting connection and any other wire harness before finally removing the center console trim/cup-holder plate (if so equipped).



6. Remove the two front center console screws (both sides).

TOOL: Phillip's screwdriver or 7mm socket



7. Remove the rubber tray in the center console storage box (if so equipped).



8. Remove the screws in the bottom of the center console storage box.

TOOLS: Ratchet, long extension, 8mm socket

NOTE: 2015MY and newer center console screws are removed from the side of the console. First remove the cover (1); then the bolts (2) with a 10mm socket.



2014MY and Earlier

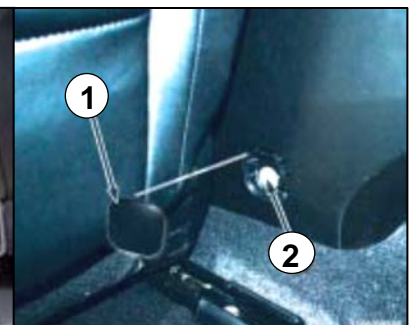

2015MY and Later
(as viewed from back seat with front seats at full forward position)

9. Raise the center console to access and disconnect the center console storage box lighting connection and any additional wiring connection clips (if so equipped).



10. Slide rearward or remove the center console to gain access to the shifter.



11. Remove rear A/C duct by lifting at rear to disengage push pin then pulling rear ward.



12. Remove the wiring routing ties from the rubber shift boot cover and fold cover out of way.



13. Unscrew rear mounting nut.

TOOLS: ratchet, long extension and 13mm socket



14. Unscrew six tunnel cover mounting nuts.

TOOLS: ratchet, long extension and 10mm socket



15. Detach shifter boot from metal tunnel cover and remove cover.



16. Unclip and pull out the two front lock pins that hold the shifter bracket to the transmission.

NOTE: This step may be able to be performed from inside the vehicle however it may be easier to access these components from underneath the vehicle. Safely use proper lift points, jack stands, etc. according to the vehicle service manual to help avoid injury if working underneath the vehicle.

*Photo taken from underneath vehicle



17. From inside the vehicle, lift up on the shifter assembly to access the lower change rod connection bolt and remove both bolt and then shifter from vehicle.

TOOLS: ratchet & 10mm socket

NOTE: This step may be able to be performed from inside the vehicle however it may be easier to access these components from underneath the vehicle. Safely use proper lift points, jack stands, etc. according to the vehicle service manual to help avoid injury if working underneath the vehicle.



18. Carefully remove both the upper and lower rubber shifter boots from the assembly. Avoid ripping or tearing the boots. If they are damaged, contact your local Dodge dealer for replacements.



ASSEMBLY

19. Install the rubber boots onto the Hurst Shifter.

NOTE: A small amount of grease on the openings of the boots can ease installation. Position the upper boot flat towards the rear of the shifter/vehicle. Make sure the upper boot seals fit into Hurst Shifter bracket grooves #1 & #2. The two front bushings in the front arms of the Hurst Shifter have been purposely designed to have a very tight to snug fit with the lock pins removed in STEP 16. Ensure that these pins can be installed into front shifter bushings prior to attempting install in vehicle. Again, a small amount of grease can aid with installation.

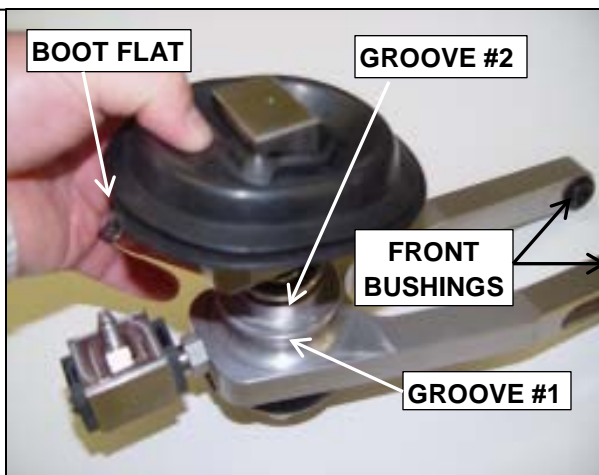

20. Position Hurst Shifter into vehicle and install change rod, change rod bolt and torque to 20 Nm (15ft-lbs).

TOOLS: torque wrench & 10mm socket

NOTE: The lower bushings in the Hurst Shifter stick have been specifically designed to operate **without** grease. Greasing this area will only attract dirt and contaminants and will not improve performance. **DO NOT** grease lower bushings.



21. Position Hurst Shifter into vehicle and install and lock front pins.

NOTE: When working from inside the vehicle a small mirror can be helpful to aid in alignment of the front pins. Not only are the front bushings very tight on the pins, they are also very tight in shifter brackets on the transmission. The pins may need to be pried into place or pried out for later removal. Use care not to damage any of the components if prying is necessary.

*Photo taken from underneath vehicle



22. Replace the metal tunnel cover and install the upper shift boot onto cover.

NOTE: Make sure the threads of the rear Hurst Shifter mount come up through the tunnel cover. Install the nut, finger tight several turns to hold it in place.



23. Install the six tunnel cover mounting nuts and torque to 20 Nm (15ft-lbs).

TOOLS: torque wrench, long extension and 10mm socket



24. Tighten the rear mounting nut and torque to 20 Nm (15 ft.lbs).

TOOLS: torque wrench, long extension and 13mm socket



25. Install the rubber shift boot cover and the wiring routing ties.



26. Install the rear A/C duct.



27. Reposition the center console into the vehicle.





28. Raise the center console to access and reconnect the center console storage box lighting connection and any additional wiring connection clips (if so equipped).

Reconnect the cup-holder lighting connection under the center console trim/cup-holder plate and any other wire harness that had been previously disconnected (if so equipped).

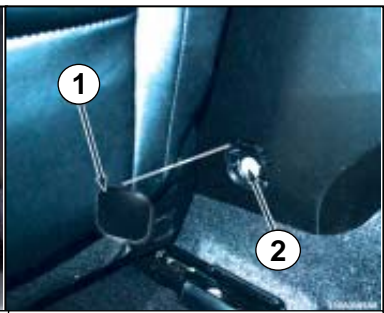

NOTE: The 12V accessory / lighter socket is part of the center console on 2015MY and newer models and will not be necessary to reconnect in this manner (see next step).

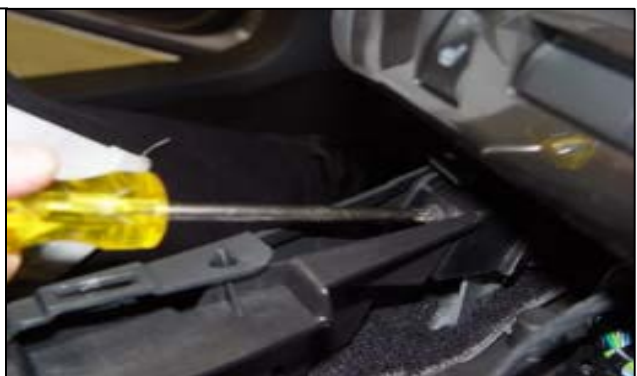

<p>29. Re-install the screws in the bottom of the center console storage box.</p> <p>TOOLS: Ratchet, long extension, 8mm socket</p> <p>NOTE: 2015MY and newer center console screws are re-installed from the side of the console. First replace the bolts with a 10mm socket (2); then the cover (1).</p>		
	<p>2014MY and Earlier</p>	<p>2015MY and Later (as viewed from back seat with front seats at full forward position)</p>

<p>30. Replace the rubber tray in the center console storage box (if so equipped).</p>	
--	---

<p>31. Re-install the two front center console screws (both sides).</p> <p>On '15 and newer reconnect the USB and main harness connection that was removed in Step 4.</p> <p>TOOL: Phillip's screwdriver or 7mm socket</p>	
--	--

<p>32. Carefully snap in the center console trim/cup-holder plate to the center console.</p> <p>NOTE: 2015MY and newer console design (1) is different than pre-2015MY vehicles and will may require reconnection of wiring to center controls if disconnected in step 3.</p>		
	<p>2014MY and Earlier</p>	<p>2015MY and Later</p>

33. Disassemble leather boot from stock stick/knob/boot assembly by prying open the boot clip or disassembly of the shifter knob/shaft removing leather boot. This photo represents a 2013 MY which may be different than the clip used on earlier/later models.

TOOL: flat blade screwdriver



34. 2008-2014 Models: Install the Boot Support onto the shift stick as show, and secure with set screw and provided hex wrench. The support should be located 1-1/4" below the bottom of the handle, with the set crew oriented with the back of the handle. 2015+ models have an expandable boot opening that will fit tightly in the shift handle. Simply insert the handle through the leather boot and proceed to step 37. Tape the end of the shifter to prevent damage to the boot.



35. Turn the leather shift boot inside out and place the stick up through it. Be sure to orient the front of the boot assembly so that the front corresponds with the front of the shift handle.



36. Use the provided zip tie to secure the leather boot to the retainer. Start by engaging the zip tie on the first "Click" and then slip it down over the boot/retainer. Tighten down by pulling with pliers. Check to be sure the zip tie is fit down into the groove of the retainer. Push down and retighten if necessary. Trim excess tail off zip tie.

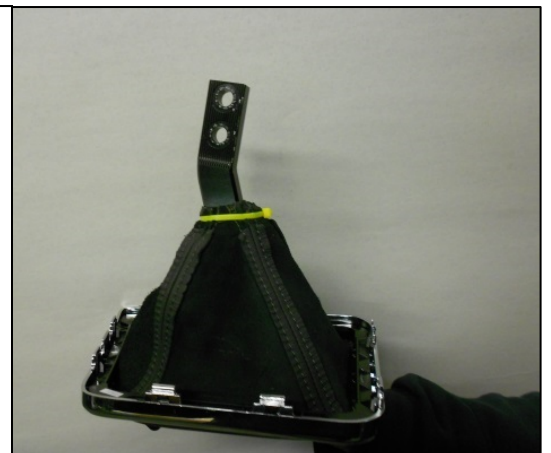

37. Bolt the stick to the shifter block

***NOTE:** The stick should be installed on the right hand side (passenger side) of the shifter block except on 2015MY and newer (mount driver side).



38. Clip the boot bezel back into place to finish the installation.



NOTE:

We have encountered concerns from some customers regarding an increase in audible noise as a result of operating harmonics and vibration that is directly transmitted through the shift linkage following the installation of the shifter. The following components can be installed to reduce this noise/vibration, however, are not intended to mask internal problems of the transmission, clutch (and related clutch components), or engine components that may have been modified. Each individual vehicle is different any may have different harmonics that change with varying vehicle, driving, wear, and atmospheric conditions. Thus, the suggestions that follow may work better in some vehicles than others and may not completely eliminate vibration noise to certain customers' satisfaction. A fair amount of experimentation and testing may be required to reduce audible vibration noise to acceptable levels.

PARTS



Dynamat® Square (2)

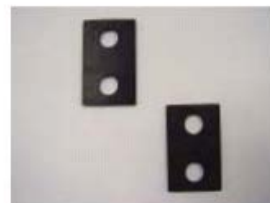

Neoprene Isolators (2)



Washers (2)



Screws (2)

DYNAMAT APPLICATION

NOTE: Apply even pressure over the entire back (foil) surfaces of the Dynamat® during installation to ensure complete and proper adhesion.

Trim Dyamat® to Size.

Note: Various effective application locations -

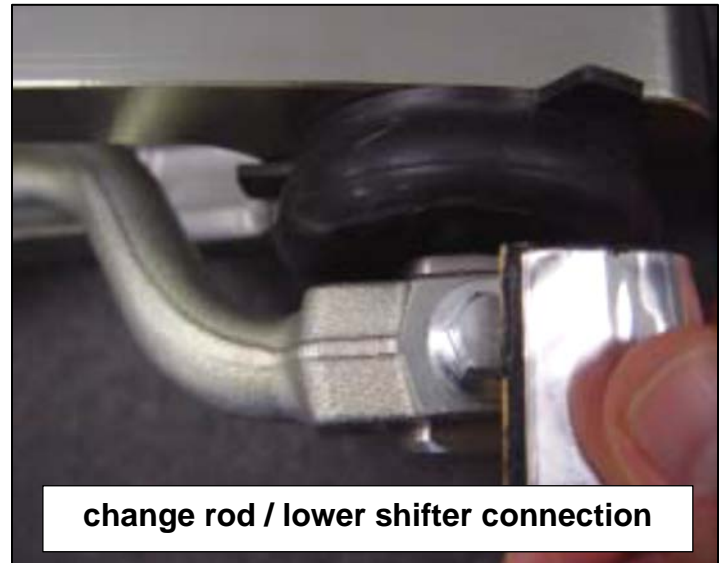
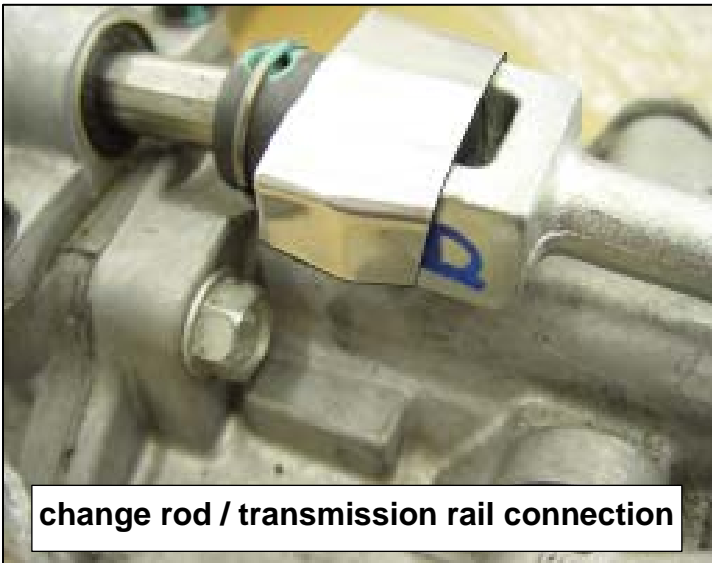

NEOPRENE ISOLATOR APPLICATION:

NOTE: This step should only be implemented if the above Dynamat® application is insufficient to eliminate noise. Do not install this if your vehicle will be used in any form of racing and/or competitive driving, as overall strength and durability as well as shift quality and feel may be diminished with the use of this kit.

Separate the upper and lower Hurst Shifter stick levers by unscrewing the connecting bolts and then position the supplied neoprene isolators (2) between the upper and lower stick halves and retighten. Ensure the bolts will not come loose during repeated hard driving. Periodic inspection and verification may be necessary.



IMPORTANT: RETAIN THESE INSTRUCTIONS FOR FUTURE REFERENCE

Technical Service

A highly trained technical service department is maintained by Hurst Performance to answer your technical questions, provide additional product information and offer various recommendations.

Technical service calls, correspondence, and warranty questions should be directed to:



Hurst Performance Products

(707) 544-4761

www.Hurst-Shifters.com