

# Classic Instruments

# SN73Z

# Zeus Link

## Installation Manual

### **Table of Contents**

Welcome from the Team at Classic Instruments! .....	2
Connecting the Zeus Link to your Vehicle .....	3
Speedometer Wiring.....	4
Fuel, Temperature, Oil pressure & Volt Wiring .....	5

Tachometer Wiring.....6  
Boost & Pressure Gauges Wiring.....7  
Direct Fit Gauge Wiring.....8

## **Welcome from the Team at Classic Instruments!**

Our congratulations and appreciation for your purchase of one of the finest quality sets of specialty instruments ever produced! Your instrument set has been conceived, designed, and manufactured by Classic Instruments, Inc. in the U.S.A. Each instrument has been tested and certified for accuracy and quality before packaging and shipping.

For trouble-free installation and operation follow the instructions exactly as outlined. Your instruments were assembled to precise specifications and although each has a seven (7) year warranty covering defective parts and workmanship – this warranty will not cover instruments or sender units which have been installed incorrectly.

Follow our recommended procedures for installation and proper hookup to maintain the value and appearance of your instrument set during many future years of accurate and dependable service!

### **LIMITED WARRANTY**

Classic Instruments, Inc. (CI) warrants to the original purchaser that any CI product manufactured or supplied by CI will be free from defects in material and workmanship under normal use and service for a period of seven (7) years from date of purchase.

Improper installation, attempted repair or adjustments by other than CI shall void this warranty. Disassembly of any instruments or senders for whatever reason shall specifically void this warranty.

It's always easy to look to a part for an issue with your set. Before you conclude that a part may be bad, thoroughly check your work. Today's semiconductors and passive components have reached incredibly high reliability levels, but there is still room for error in our human construction skills. However, on rare occasions a sour part can slip through. Please be aware that testing can usually determine if the part was truly defective or damaged by assembly or usage. Don't be afraid of telling us that you "blew it", we're all human and in most cases, replacement parts are very reasonably priced.

Purchaser requesting a product to be repaired or replaced under warranty must first call CI at 1-800-575-0461 before the return of defective part. Send defective part to 826 Moll Drive, Boyne City, MI 49712, USA. Include a written description of the failure with defective part.

Purchaser agrees and accepts that under no circumstances will a warranty replacement be furnished until CI has first received, inspected, and tested the returned part.

All other warranties expressed or implied are hereby excluded including any implied warranty of merchandise and implied warranty of fitness for a particular purpose. The sole and exclusive remedy for breach of this warranty is limited to the replacement set forth above.

It is expressly agreed that there shall be no further remedy for consequential or other type of damage, including any claim for loss of profit, engine damage or injury.

#### **TECHNICAL ASSISTANCE**

**1-800-575-0461**

**OR**

**Visit our website for the latest in gauge design and updates to our installation manual**

**[www.classicinstruments.com](http://www.classicinstruments.com)**

## **Connecting the Zeus Link to your Vehicle**

- 1) Connect +12V keyed & fused power to the "+12VDC" position of the Zeus Link.
  - a. *(a 5A fuse is recommended)*
- 2) Connect a good ground to the "GROUND" position of the Zeus Link.
- 3) Connect a dash light power wire to the "DASHLTS" position of the Zeus Link.
- 4) Connect the included CAN network cable between your vehicle's OBDII connector or Holley ECU to the "CONN." position of the Zeus Link.

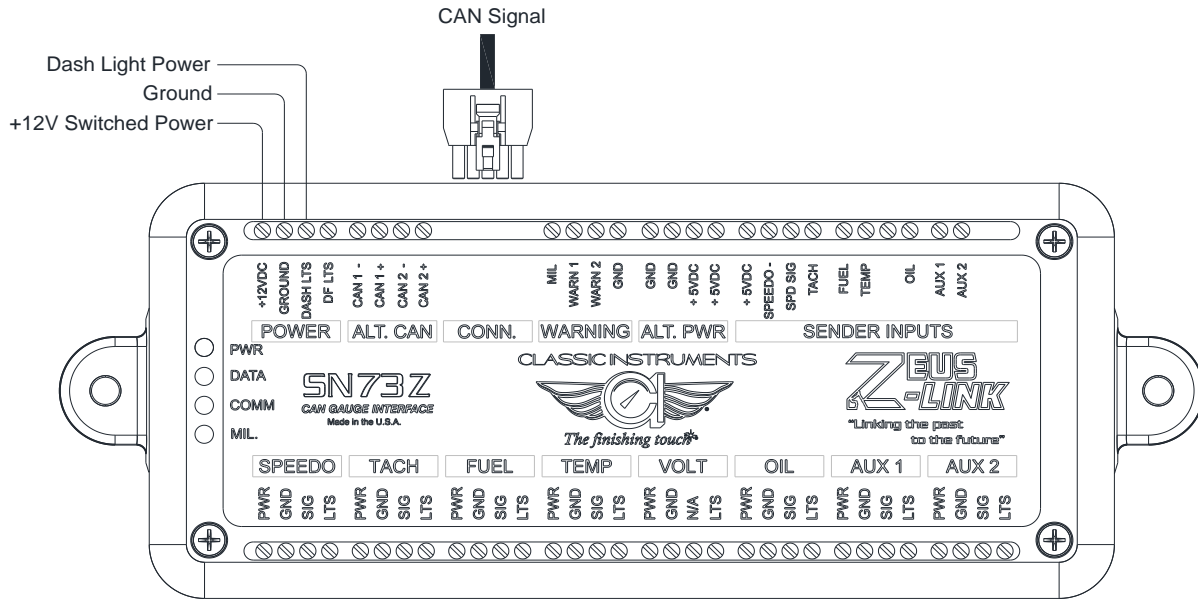

## Speedometer Wiring

- 1) Connect the speedometer's power [Pink] wire to the SPEEDO "PWR" position of the Zeus Link.
- 2) Connect the speedometer's ground [Black] wire to the SPEEDO "GND" position of the Zeus Link.
- 3) Connect the speedometer's signal [Purple] wire to the SPEEDO "SIG" position of the Zeus Link.
- 4) Connect the speedometer's dash light [Grey] wire to the SPEEDO "LTS" position of the Zeus Link.
- 5) ***If you are not getting a speed signal from the vehicle's CAN network, connect the speed input to the SENDER INPUTS "SPD SIG" position of the Zeus Link. (If you are using a***

Holley Fuel Injection System ECU that is not controlling your transmission, the vehicle speed will not be available on the CAN bus, and you will need to get a speed signal from your vehicle speed sensor, ECU speed output, or other method.)

- a. White wire from a pulse signal generator [SN16]
  - i. Connect the **Red** wire of the SN16 to the SENDER INPUTS “+5VDC” position of the Zeus Link.
  - ii. Connect the **Black** wire of the SN16 to the SENDER INPUTS “SPEEDO-” position of the Zeus Link.
- b. One wire (either) of an electronic transmission 2-wire vehicle speed sensor (VSS).
  - i. Connect the other wire of the VSS to the SENDER INPUTS “SPEEDO-” position of the Zeus Link.

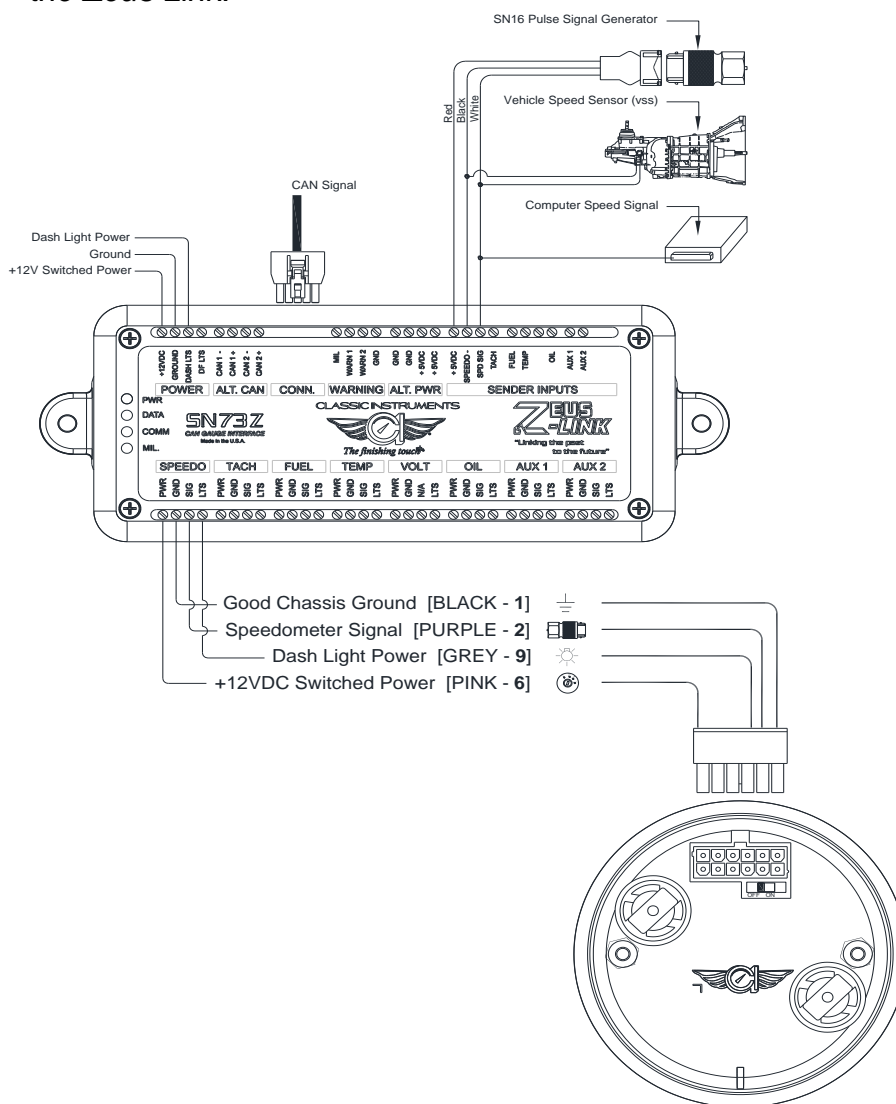

## Fuel, Temperature, Oil pressure & Volt Wiring

- 1) Connect each gauge’s power connection to the FUEL, TEMP, VOLT, or OIL “PWR” position of the Zeus Link.
- 2) Connect each gauge’s ground connection to the FUEL, TEMP, VOLT, or OIL “GND” position of the Zeus Link.

- 3) Connect each gauge's signal connection to the FUEL, TEMP, or OIL "SIG" position of the Zeus Link.
  - a. *The volt gauge doesn't require a signal.*
- 4) Connect each gauge's dash light connection to the FUEL, TEMP, VOLT, or OIL "LTS" position of the Zeus Link.
- 5) **If you are not getting a signal from the vehicle's CAN network, connect a signal to the SENDER INPUTS "FUEL", "TEMP", or "OIL" position of the Zeus Link.**
  - a. *The volt gauge doesn't require a signal.*

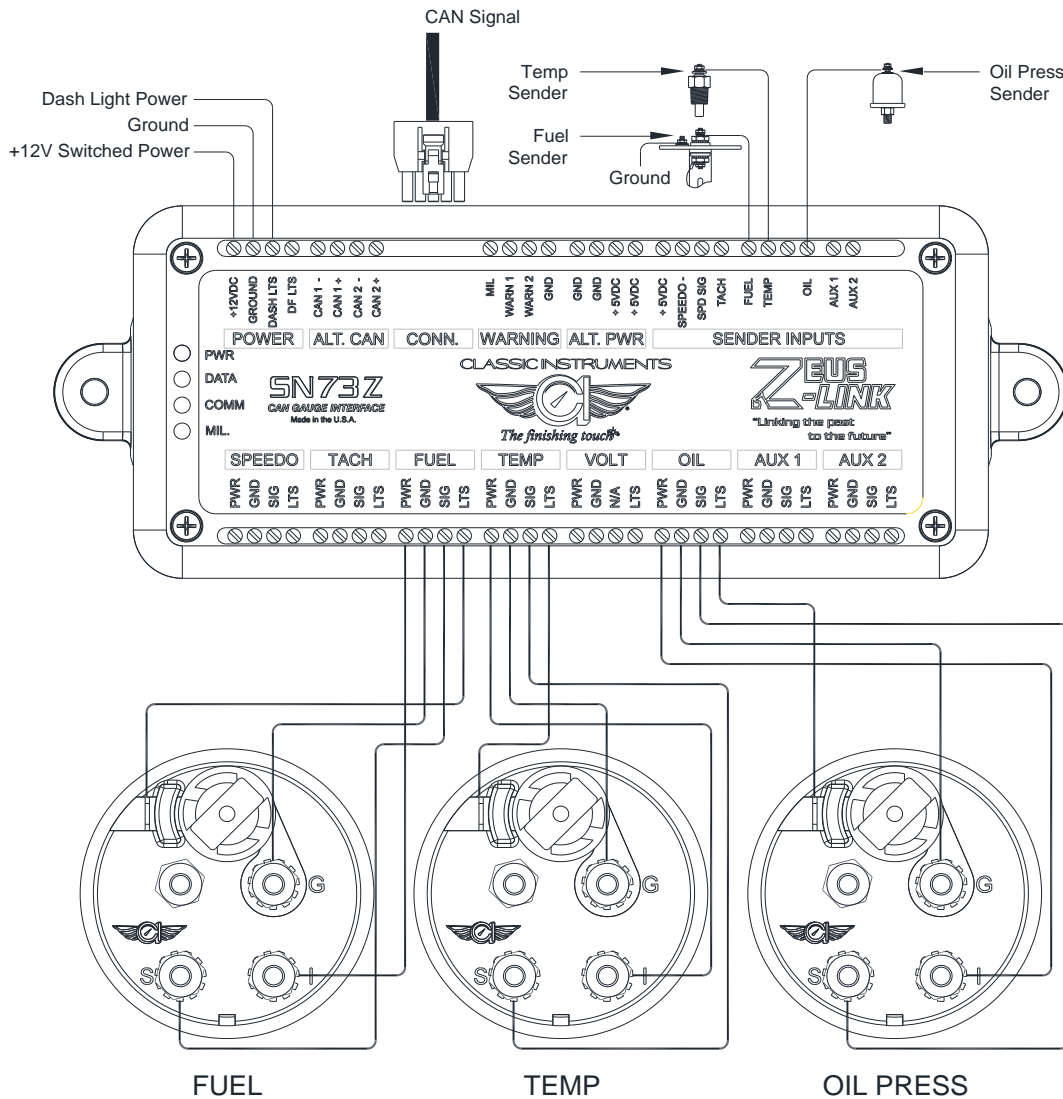

## Tachometer Wiring

- 1) Connect the tachometer's power [Pink] wire to the TACH "PWR" position of the Zeus Link.
- 2) Connect the tachometer's ground [Black] wire to the TACH "GND" position of the Zeus Link.
- 3) Connect the tachometer's signal [White] wire to the TACH "SIG" position of the Zeus Link.
- 4) Connect the tachometer's dash light [Grey] wire to the TACH "LTS" position of the Zeus Link.

5) **If you are not getting a tach signal from the vehicle's CAN network, connect a tach input to the SENDER INPUTS "TACH" position of the Zeus Link.**

**a. STANDARD POINTS & CONDENSER SYSTEM**

Connect the negative side of the coil (usually marked as "-") to the white wire of the gauge harness.

**b. GMC – HEI (High Energy Ignition System)**

Connect the "TACH" terminal on coil side of distributor cap to the white wire of the gauge harness.

**c. MSD (Multiple Spark Discharge System)**

Connect the Tach signal on the MSD box to the white wire of the gauge harness.

**d. MULTIPLE COIL IGNITION SYSTEMS**

A tach adapter is required for these ignition systems. A tach signal driver such as the MSD #8913, which produces a 12V square wave signal, is recommended.

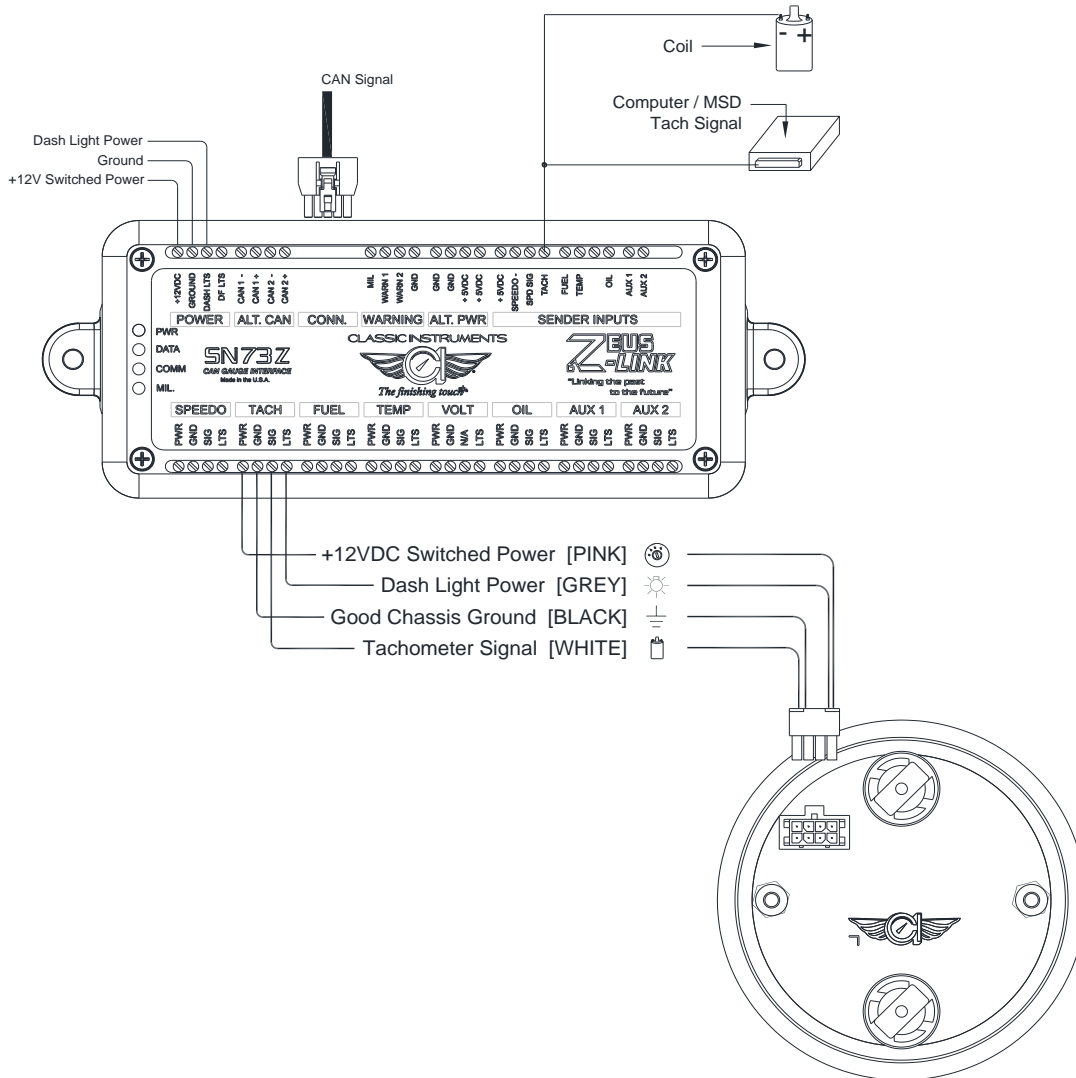

**Boost & Pressure Gauges Wiring**

- 1) Connect each gauge's power wire [Pink] to the AUX1 or AUX2 "PWR" position of the Zeus Link.
- 2) Connect each gauge's ground wire [Black] to the AUX1 or AUX2 "GND" position of the Zeus Link.
- 3) Connect each gauge's signal wire [White] to the AUX1 or AUX2 "SIG" position of the Zeus Link.

- 4) Connect each gauge's dash light wire [Grey] to the AUX1 or AUX2 "LTS" position of the Zeus Link.
- 5) **If you are not getting a signal from the vehicle's CAN network, connect a signal to the SENDER INPUTS "AUX1" or "AUX2" position of the Zeus Link.**
  - a. Connect the power wire of each boost / pressure sender [Red] to the ALT. PWR "+5VDC" position of the Zeus Link.
  - b. Connect the ground wire of each boost / pressure sender [Black] to the ALT. PWR "GND" position of the Zeus Link.

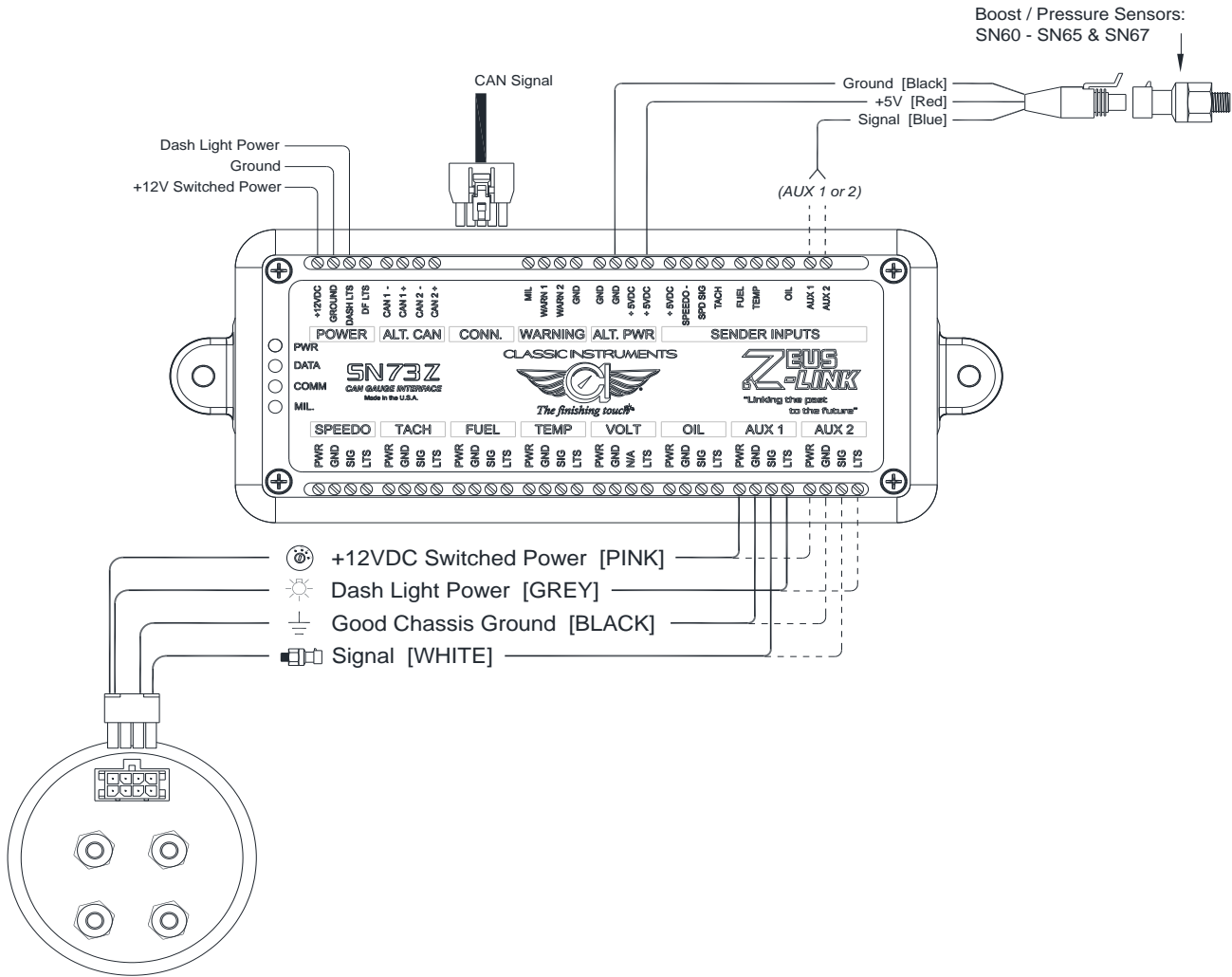

## Direct Fit Gauge Wiring

- 1) Connect the gauge harness's power [Pink] wire to the SPEEDO "PWR" position of the Zeus Link.



- 2) Connect the gauge harness's ground [Black] wire to the SPEEDO "GND" position of the Zeus Link.
- 3) Connect the gauge harness's dash light [Grey] wire to the "DF LTS" position of the Zeus Link.
- 4) Connect the gauge harness's speed signal [Purple] wire to the SPEEDO "SIG" position of the Zeus Link.
- 5) Connect the gauge harness's tach signal [White] wire to the TACH "SIG" position of the Zeus Link.
- 6) Connect the gauge harness's fuel signal [Tan] wire to the FUEL "SIG" position of the Zeus Link.
- 7) Connect the gauge harness's temperature signal [Dk. Green] wire to the TEMP "SIG" position of the Zeus Link.
- 8) Connect the gauge harness's oil pressure signal [Dk. Blue] wire to the OIL "SIG" position of the Zeus Link.
- 9) If you are not getting a signal from the vehicle's CAN network, connect the signal input to the appropriate SENDER INPUTS position of the Zeus Link. (see previous sections of this document for reference)

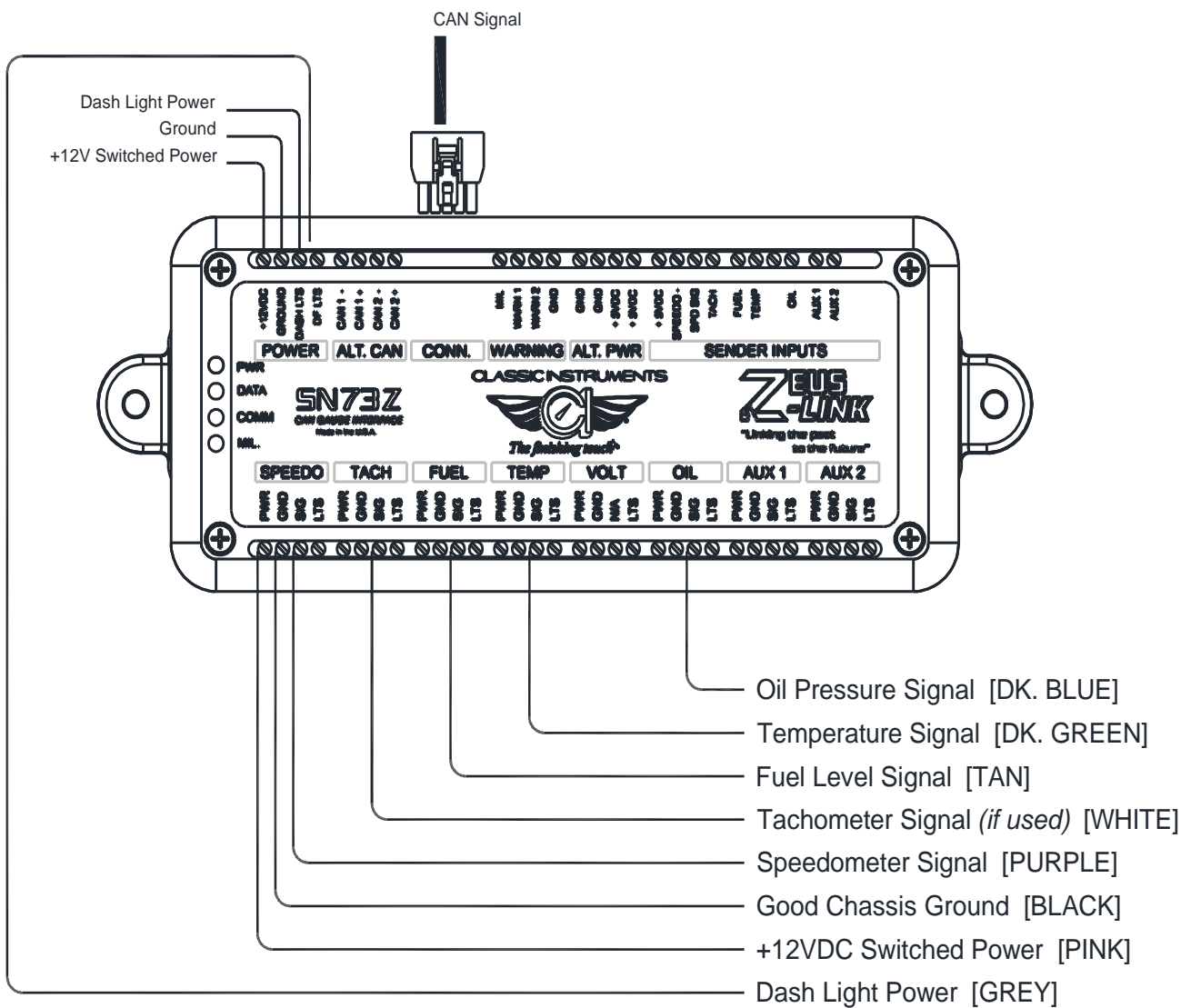

## Zeus Link App

- 1) Connect the Zeus Link module to your vehicle CAN or OBD2 network.
- 2) Apply power to the Zeus Link module.
- 3) Ensure that Bluetooth is enabled on your mobile device.
- 4) Start the Zeus Link app. When prompted, select your data source you will use with the Zeus Link.

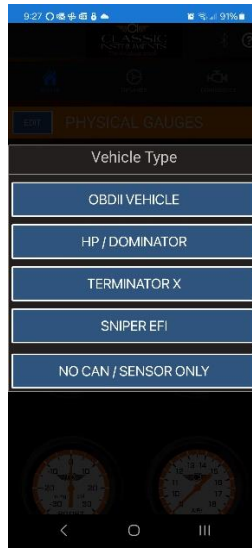

- 5) Add the physical gauges you have connected to the Zeus Link module to the app. To add a gauge, tap the wrench button shown over one of the gauge place holders on the screen. Choose the virtual gauge setting that matches your physical gauges.



- a. Speedometer configuration:
  - i. Select your input source for your speed signal and the maximum speed scale of your speedometer. Tap "UPDATE" to apply your changes.



b. Tachometer configuration:

- i. Select your input source for your tach signal and the maximum RPM scale of your tachometer. Tap “UPDATE” to apply your changes.

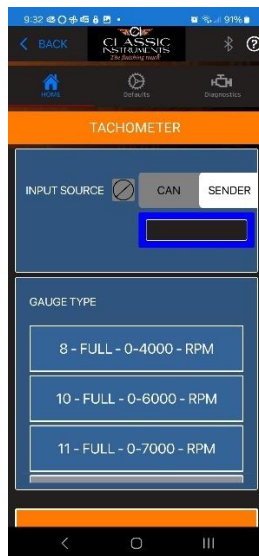

c. Fuel configuration:

- i. Select what resistance range the fuel sending unit you have connected to the Zeus Link module has.

- ii. Select if the fuel gauge rotates a “QUARTER” circle (from empty to full) or a three-quarter circle “FULL” (from empty to full). Tap “UPDATE” to apply your changes.

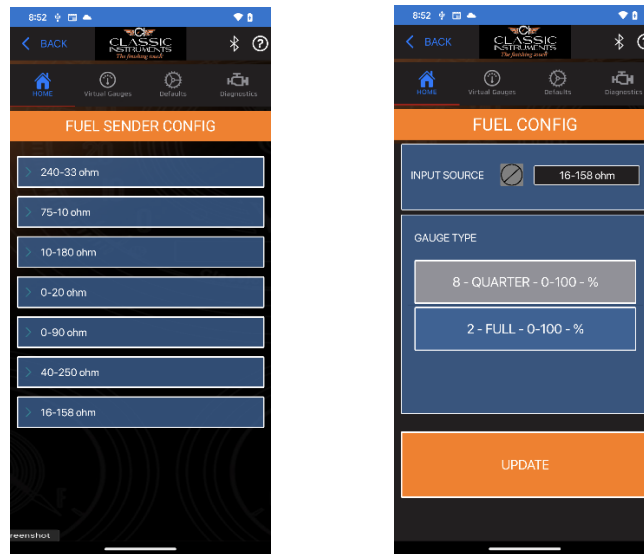

d. Coolant temperature configuration:

- i. Select your input source for your temperature signal.
- ii. Select if the temperature gauge rotates a “QUARTER” circle (from min to max) or a three-quarter circle “FULL” (from min to max). Tap “UPDATE” to apply your changes.

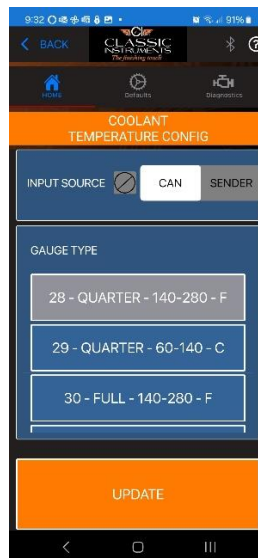

e. Voltage configuration:

- i. Input source is not required for this gauge.

- ii. Select if the voltage gauge rotates a “QUARTER” circle (from min to max) or a three-quarter circle “FULL” (from min to max). Tap “UPDATE” to apply your changes.

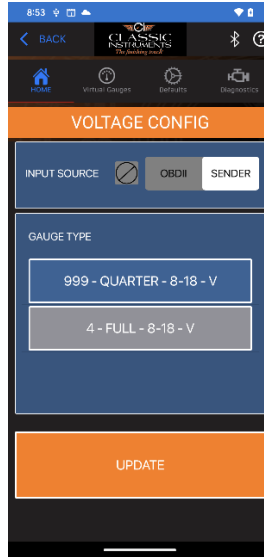

- f. Oil pressure configuration:
  - i. Select your input source for your oil pressure signal.
  - ii. Select if the oil pressure gauge rotates a “QUARTER” circle (from min to max) or a three-quarter circle “FULL” (from min to max). Tap “UPDATE” to apply your changes.



- 6) Once all your physically connected gauges have been entered, press the “DONE” button.
  - a. Select “YES” to save this configuration to the Zeus Link module.

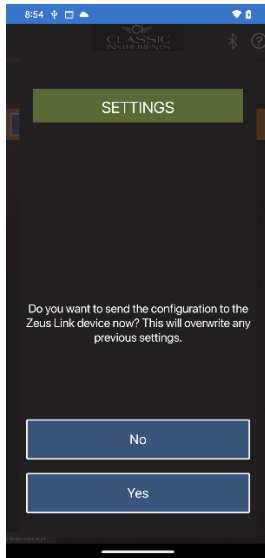

## ***Diagnostics***

The diagnostics tab at the top of the Zeus Link app gives valuable information about each gauge.

From the diagnostics tab, you can also check the calibration and functionality of each gauge you have connected.

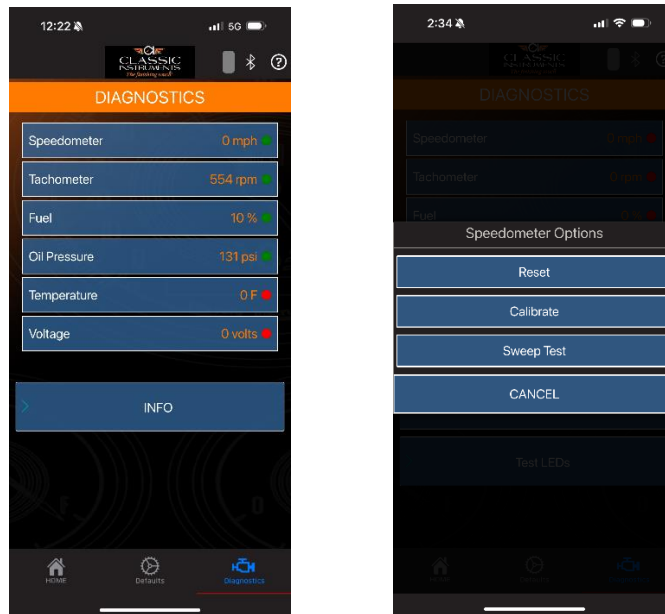

Tapping on any of the gauges listed will give you the option to reset, calibrate or do a sweep test on that gauge. A sweep test will move the gauge through its complete range to ensure the gauge is moving properly and wired properly.