

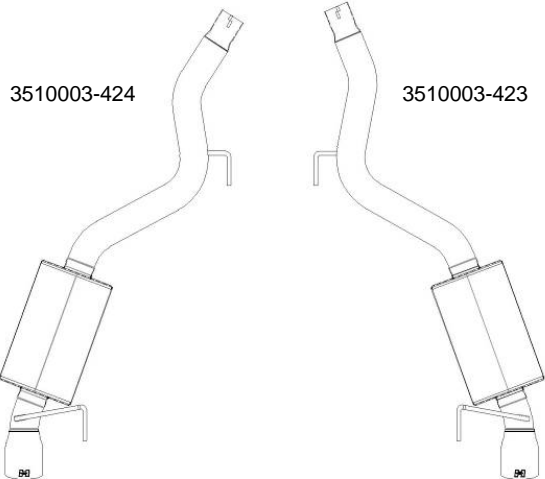

AN AMERICAN ICON...SINCE 1958

304 Stainless Steel

Installation Instructions for:
SYSTEM #6350027
2015-2018 MUSTANG BASE
2.3L · L4 & 3.7L · V6 ENGINE
Fits Fast-Back and Convertible Models.



PACKING LIST		
Qty	Description	Part#
1	Right Muffler Assembly.	3510003-423
1	Left Muffler Assembly.	3510003-424
1	Hardware Pack	PK798
2	2 1/4" Clamp	MC225BS

10/10/16

Removal:

1) Raise the vehicle up on a hoist or rack to working height. If you don't have access to a hoist or rack, raise the vehicle and support securely with jack stands. To ease the removal of the stock system, spray a penetrating lubricant onto the rubber hangers just behind the rear differential and also at the rear of the vehicle.

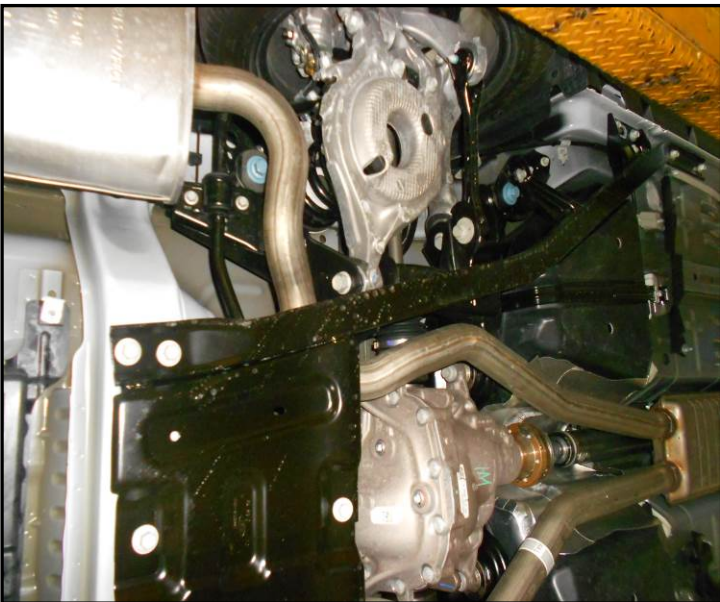
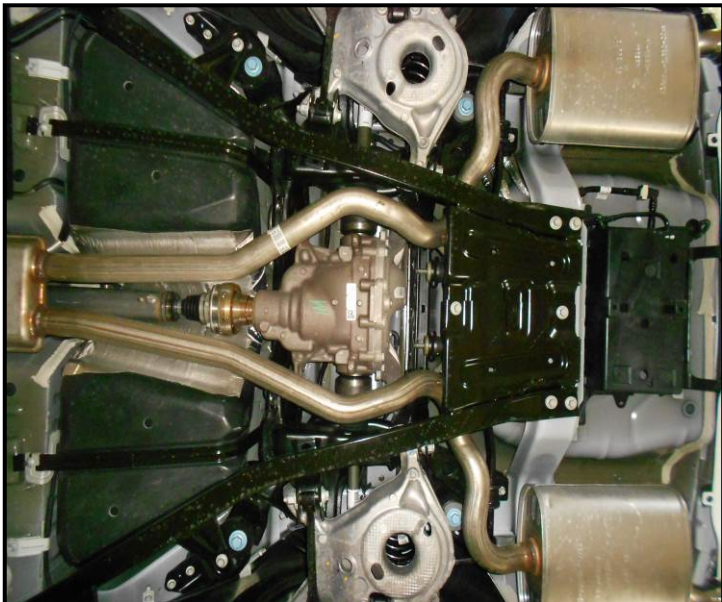

2) On convertible model vehicles, the body braces shown in the photos above will need to be removed in order to remove the factory system and install the Hurst system. Starting at the front of the right side (passenger) brace, loosen the front bolt and then work your way to the rear of the vehicle removing the next eight bolts. Once the bolts have been removed, lower the brace from the vehicle. Repeat this step on the left side of the vehicle with the six bolts on that side.

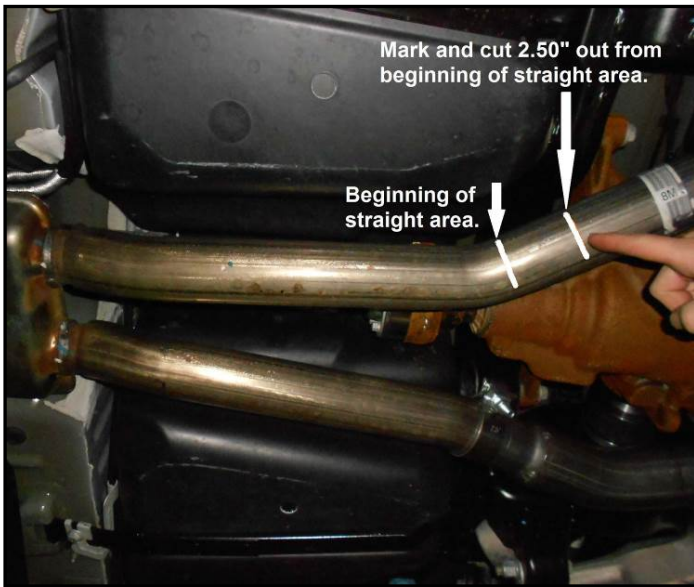

3) Begin by measuring back 2 ½" from the beginning of the straight area shown in the photo above and make a mark on both pipes. Support the exhaust system both in front and behind the area to be cut, then once you've double checked that the measurements are correct, cut both pipes at the marks. **Note: Due to the closeness of the pipes to the gas tank, use caution when cutting!** Using a 13mm wrench, unbolt the two hangers just behind the rear differential from the cross member. Carefully lower the stand under each muffler and slide the muffler assembly forward and out of the rear hanger mount. Lower the assemblies to the floor, leaving the front hangers attached. Carefully deburr the end of the pipes where cut with a file or die grinder. Finally, remove the two hanger mounts at the rear of the vehicle from the frame using a 13mm wrench, as you remove them place them with the factory muffler from the corresponding side.

Installation:



1) Place the new Hurst muffler units next to the factory units and swap the front and rear hanger mounts from the stock mufflers to the Hurst assemblies. Also, place a provided 2.25" clamp onto the inlet of each assembly. Tighten the clamp just enough to hold in place.

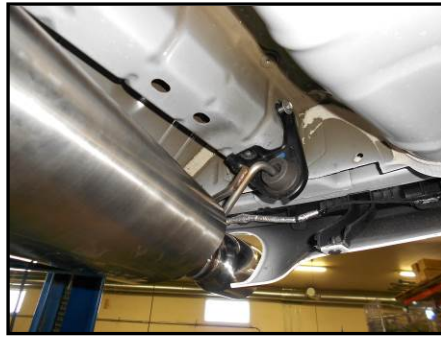

- 2) Place the right muffler assembly **#3510003-423** up into position and slide the inlet onto the factory pipe approximately 2 ¼". Support the assembly with a stand and remount the rear hanger mount to the frame and tighten securely. Remount the front hanger to the cross member and tighten securely. Leave the clamp on the inlet loose for now. Repeat this step with muffler assembly **#3510003-424** on the left side of the vehicle.
- 3) On convertible models, re-install the two body braces and securely fasten using the hardware removed in step 2 of the removal instructions above.
- 4) Adjust and level the two muffler assemblies to provide a satisfactory fit. A minimum of 1/2" clearance around all parts of the system must be maintained; while keeping suspension travel and vibration in mind. After adjustments have been made, you may now securely tighten the two muffler inlet clamps.
- 5) For a more secure installation, we highly recommend placing a minimum 1" weld on either side of the inlet slip-fit connections.