

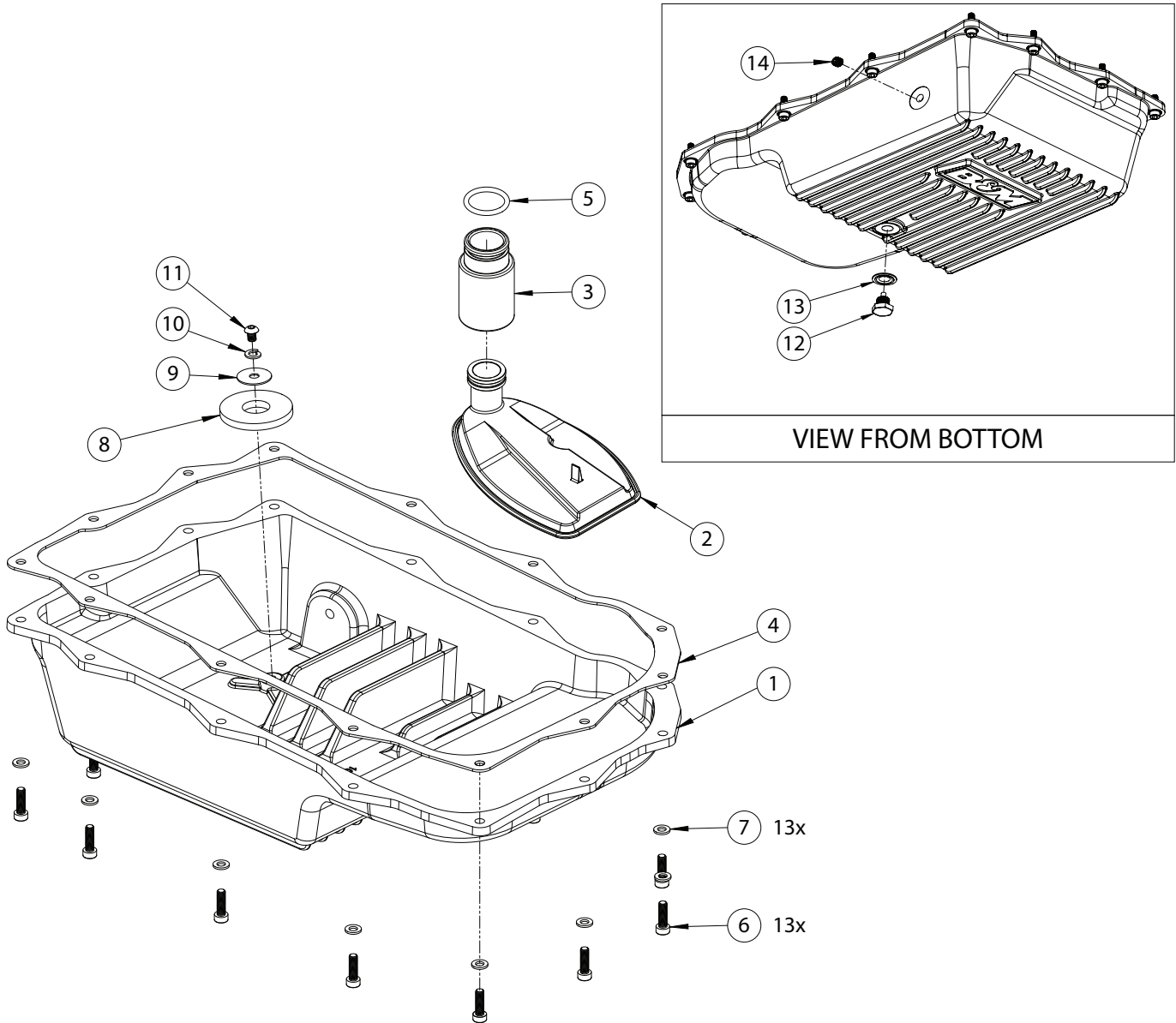

Installation Instructions 70395 & 71395

2013-2024 DODGE 1500 TRUCKS
2019-2024 2500/3500
ZF 845RE 850RE, 8HP70, & 8HP75 TRANS



ITM #	PART #	DESCRIPTION	QTY.
1	1000503	Deep Pan (Natural)	1
	1000506	Deep Pan (Black)	
2	1601026	Deep Pan Filter	1
N/A	70395BA-01	Hardware Package includes:	1
3	1400481	Filter Machining Extension	1
4	1400019	Pan Gasket	1
5	3401721	O-Ring	1
6	3401486	M6-1.0 x 25MM Bolt	13

ITM #	PART #	DESCRIPTION	QTY.
7	3401487	M6 Flat Washer	13
8	3401528	Ring 2.1" OD x .8" ID Magnet	1
9	3401488	¼ Flat Oversized Washer	1
10	3401195	M6 Lock Washer	1
11	3401466	M6 x 10MM Bolt	1
12	3401109	½-20 Magnetic Drain Plug Bolt	1
13	3401110	½" Drain Gasket	1
14	3401485	¼ Socket Plug - Dryseal	1

OVERVIEW:

Thank you for purchasing B&M 70395 Transmission Pan. This kit is designed to work with 845RE & 8HP70 transmissions. Be sure to acquire your vehicles factory fill procedure, prior to beginning project.

B&M also offers the following related products:

Temperature Gauge (80212): Add a gauge to monitor your transmission fluid temperature.



1. Please take a moment to read and understand these instructions before beginning your install, using diagram and list to verify kit contents.

REMOVE FACTORY TRANSMISSION PAN:

WARNINGS:

- Automatic transmissions operate at temperatures between 150° and 250°. To avoid burns from hot oil and parts, allow vehicle to cool off for a few hours before beginning installation.
- Maintain clean working surface as transmission components are precision fit so any dirt will directly impact success of installation.
- Vehicle must be level for stability and to obtain an accurate fluid level.

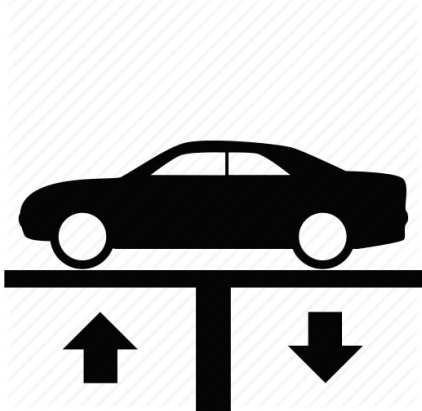

2. Raise vehicle up on a hoist or rack to working height. If you don't have access to a hoist or rack, raise vehicle and support securely with jack stands.

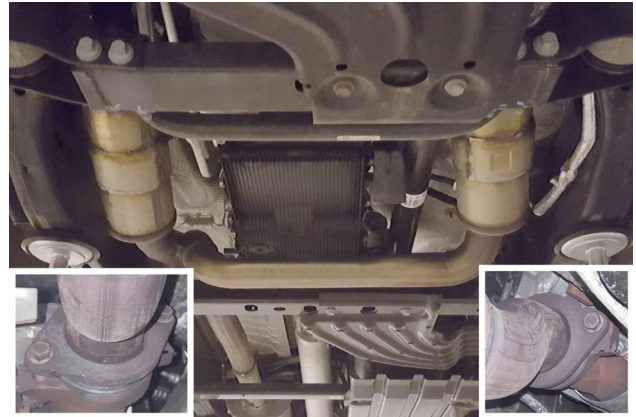

3. If you have limited access to your transmission pan, unbolt exhaust flanges from manifolds and lower exhaust system onto stands.

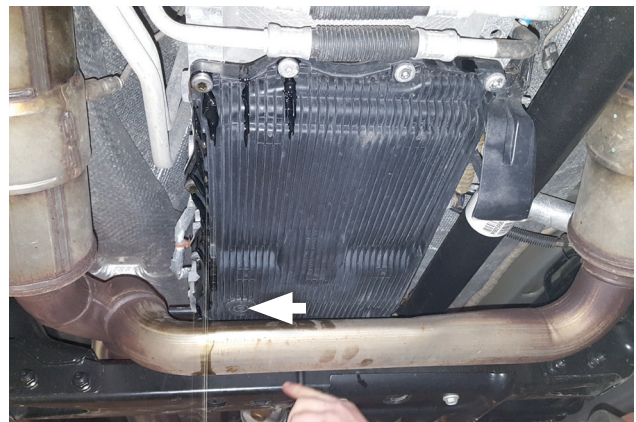

NOTE: To avoid fluid draining onto your exhaust pipes, use a funnel to direct it into your pan.

4. Remove plug to drain transmission fluid from pan into clean container so you can re-use it later.



5. Remove (x13) factory bolts and pan from vehicle.

ASSEMBLE AND INSTALL FLOWMASTER PERFORMANCE TRANSMISSION PAN:

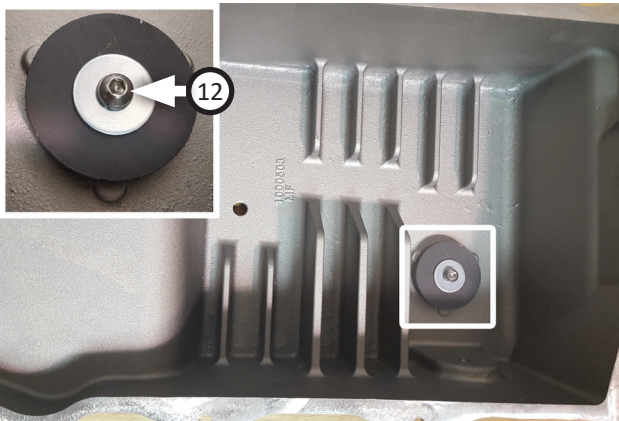

6. Apply loktite onto threads of bolt (12) then install it through lock washer (13), oversized flat washer (11), and magnet ring (10) into deep pan (1).

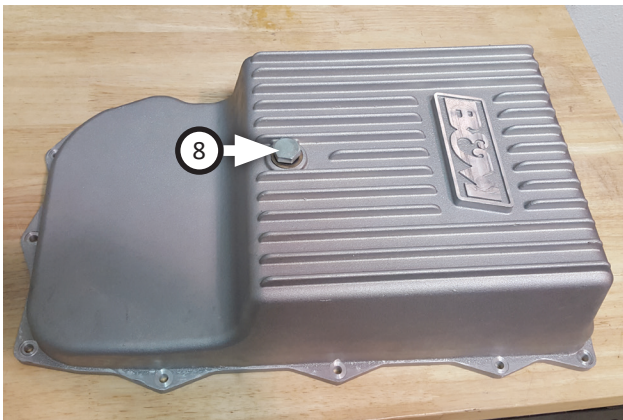

7. Fasten plug bolt (8) through drain gasket (9) into deep pan as shown.

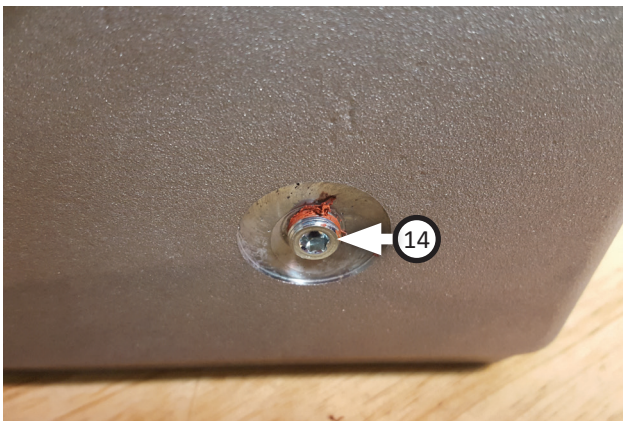

8. Install socket plug (14) onto side of deep pan as shown.

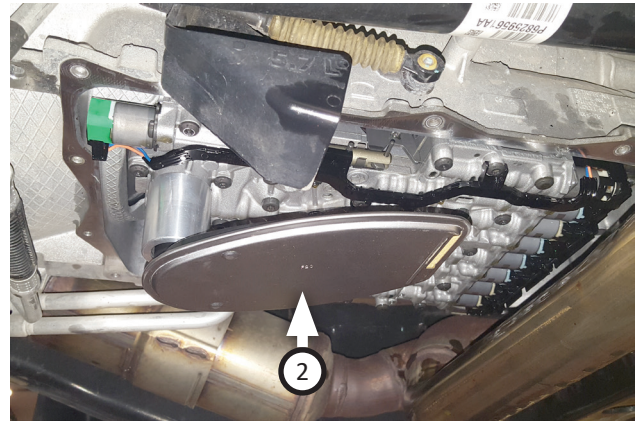

9. Install o-ring (5) onto filter extension (3) then attach it onto deep pan filter (2). Install filter assembly onto transmission oriented as shown.

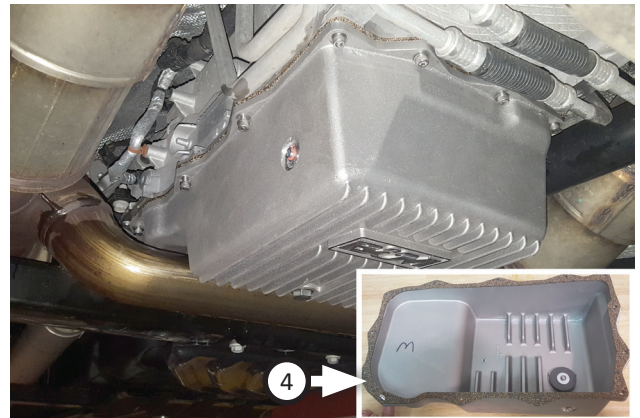

10. Set gasket (4) onto deep pan then set it into place on transmission, securing it with (x13 ea.) bolts (6) and flat washers (7). Torque screws to 8ft lbs.

CAUTION:
Do NOT force pan into place, but adjust filter as necessary to allow pan to fully contact sealing surface.

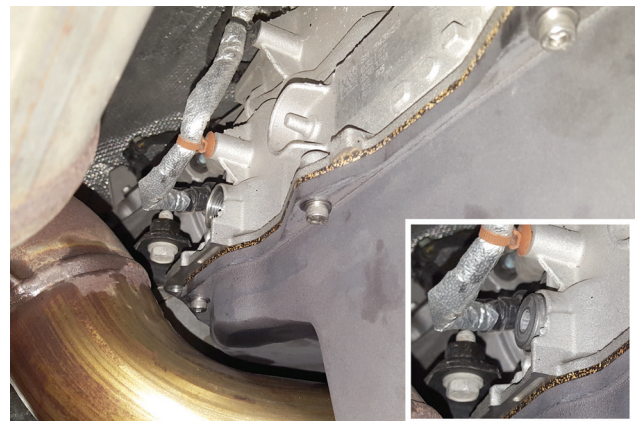

11. Remove fill plug just above pan, and retain it for later.

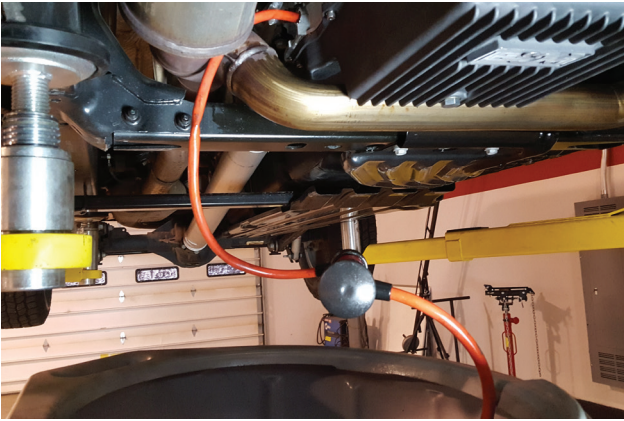

12. Complete fill procedure on last page.



Congratulations, the installation of your **B&M Racing performance Transmission Pan** is now complete!

FILL PROCEDURE:

Read complete fill procedure before beginning.

WARNING:

There is a risk of accident from vehicle moving while engine is running. Secure vehicle to prevent it from moving. There is a risk of injury from contusions and burns if you insert your hands into engine while it is running. Do NOT touch hot or rotating parts. Wear properly fitted work clothes.

CAUTION:

A unique transmission fluid has been developed for this transmission. This fluid is NOT compatible with ATF+4 or any previous MOPAR fluids. Use factory 8 speed MOPAR fluid.

NOTE: Oil dye is not recommended to find leaks in the 8HP transmission. The oil dye can cause shift quality issues and is NOT recommended. The 8HP fluid has illuminance that is visible under a black light.

1. Raise and support vehicle level with wheels off ground.
2. Remove fill plug then fill transmission until fluid reaches bottom of fill hole.
3. Start engine (leave vehicle running for following procedure).
4. Using a scan tool or vehicle information center, verify that transmission fluid temperature is between 30°C (86°F) and 50° (122°F).
5. Add transmission fluid until it trickles from fill opening.
6. Install transmission fill plug and tighten to proper torque specifications.

7. With brakes applied, place transmission in Reverse and hold for 5 seconds.
 8. Place transmission in Drive and hold for 5 seconds.
 9. Release brakes, slowly accelerate to 2nd gear and hold for 5 seconds.
 10. Apply brakes and place transmission into Neutral.
 11. Raise engine speed to 2000 RPM for 5 seconds.
 12. Return engine to idle and place transmission in Park.
- NOTE:** A full transmission will have fluid at fill hole with transmission between 30°C (86°F) and 50° (122°F). Do not over fill.
13. Remove transmission fill plug and allow excess fluid to drain from fill hole or add fluid as necessary.
 14. Install transmission fill plug and tighten to proper torque specification.

