



Installation Instructions

717998

2023-2024

Chevrolet Colorado/GMC Canyon
2.7L Turbo Engine

High Clearance Rear Exit Tailpipe

Installation requires moderate mechanical skill. If this job is beyond your abilities, seek the services of a qualified technician.

If you do not understand any part of these instructions, please call Flowmaster Technical Support at (866) 464-6553 for assistance.

Apply penetrating oil generously to clamps, fasteners, pipes, and hanger rods for ease of disassembly.

REVIEW THE INSTRUCTIONS & VERIFY THE KIT CONTENTS

Take a moment to read and understand these instructions before installing your Flowmaster exhaust kit.

Item#	Part #	Description	Qty.
1	26965M	Inlet Pipe	1
2	71249-Z	Muffler	1
3	26966M	Muffler Outlet Pipe	1
4	26967M	Tailpipe	1
5	MC300BS	3" band Clamp	3
6	HW503	½" Push Nut	5

Use the parts drawing and list to identify components and verify your kit's contents. In the unlikely event that any parts are missing, please contact Flowmaster Technical Support for replacements.

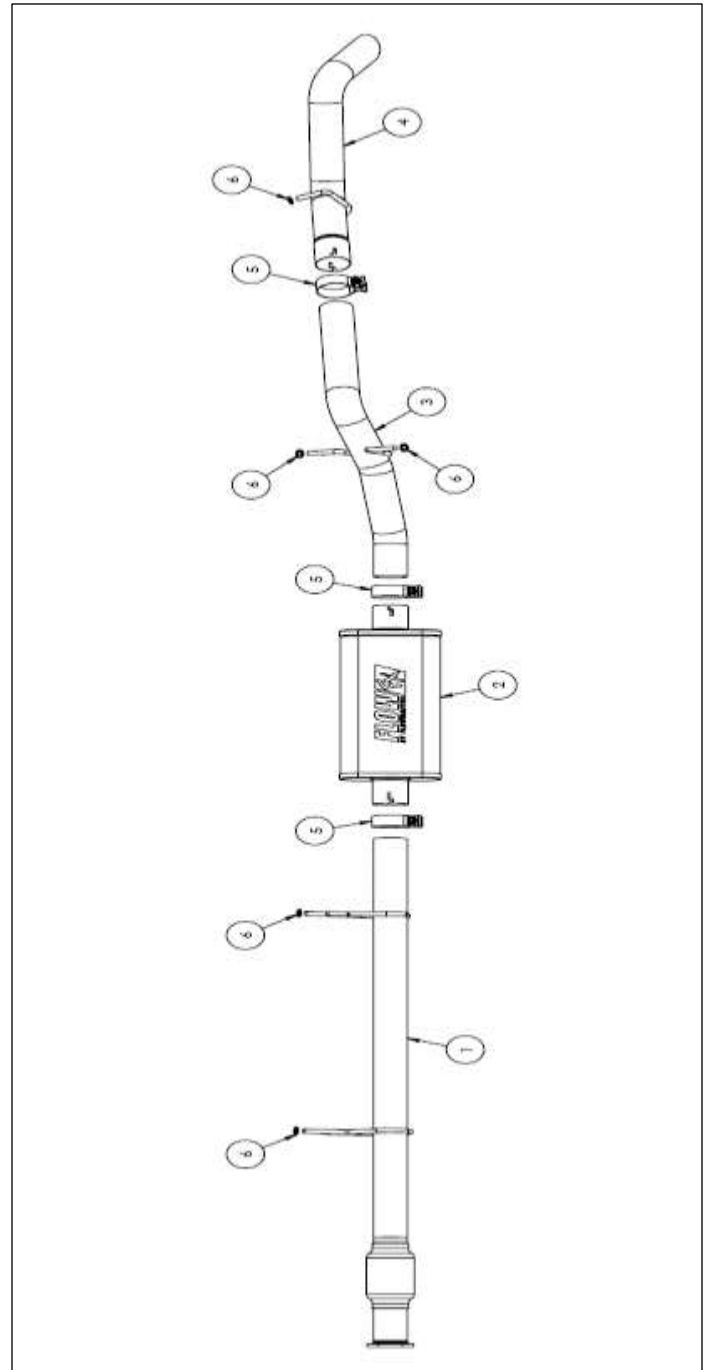

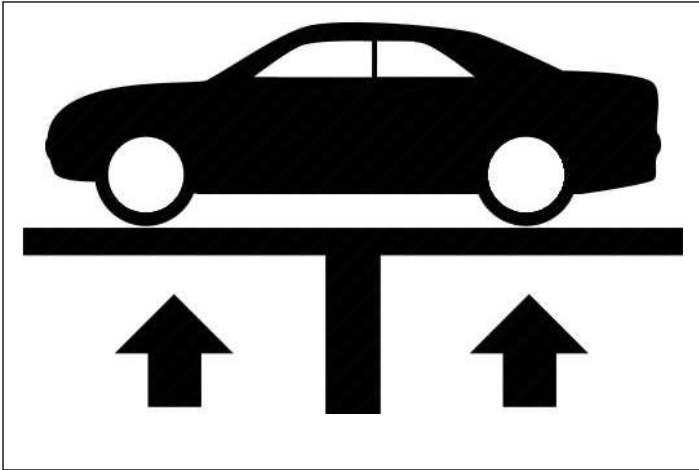

Vehicle Compatibility

Model Year: **2023-2024**

Make: **Chevrolet Colorado/ GMC Canyon**

Engine: **2.7L Turbo**

- **Two Wheel Drive and Four Wheel Drive**

BEFORE STARTING:

Raise the vehicle to a minimum of eighteen inches. A floor hoist is ideal. If no hoist is available, we strongly urge the use of axle stands as a safety measure. **Please read and understand these instructions and disclaimer in their entirety before attempting installation.**

CAUTION! WORK ONLY ON A LEVEL SURFACE. USE JACKS /JACK STANDS OF SUFFICIENT CAPACITY TO LIFT AND SUPPORT YOUR VEHICLE. NEVER WORK UNDER A VEHICLE SUPPORTED BY A FLOOR OR BUMPER JACK.

Removing the OEM Exhaust:

NOTE: Cutting the Factory exhaust for removal is recommended but not necessary. Removing the factory exhaust can be done as one piece. (See exhaust removal special note)

Please read and follow all instructions before attempting to install this exhaust system.

Removing the OEM Exhaust:

1. Apply penetrating oil to each rubber hanger on the exhaust.
2. Remove the (x2) 15mm nuts at the two-bolt flange connection. **Fig. 1**
3. Cut the exhaust pipe just before the muffler with a reciprocating saw. **Fig. 1**
4. Remove the (x5) rubber isolators from the hanger rods.
5. Remove the exhaust from the vehicle in two sections.

Special Note: Removing the exhaust without cutting.

A lift is needed to raise the vehicle. Remove the spare tire and heat shield. Remove the nuts at the 2-bolt flange, and remove the rubber hanger isolators. With the rear suspension fully extended, the entire exhaust assembly can be pushed back over the rear axle and rotated far enough to get the front flange past the crossmember. Drop the front of the exhaust and remove the assembly towards the front of the vehicle until the tailpipe clears the rear axle.

Caution: Be very careful not to damage the drive shaft while removing the exhaust.

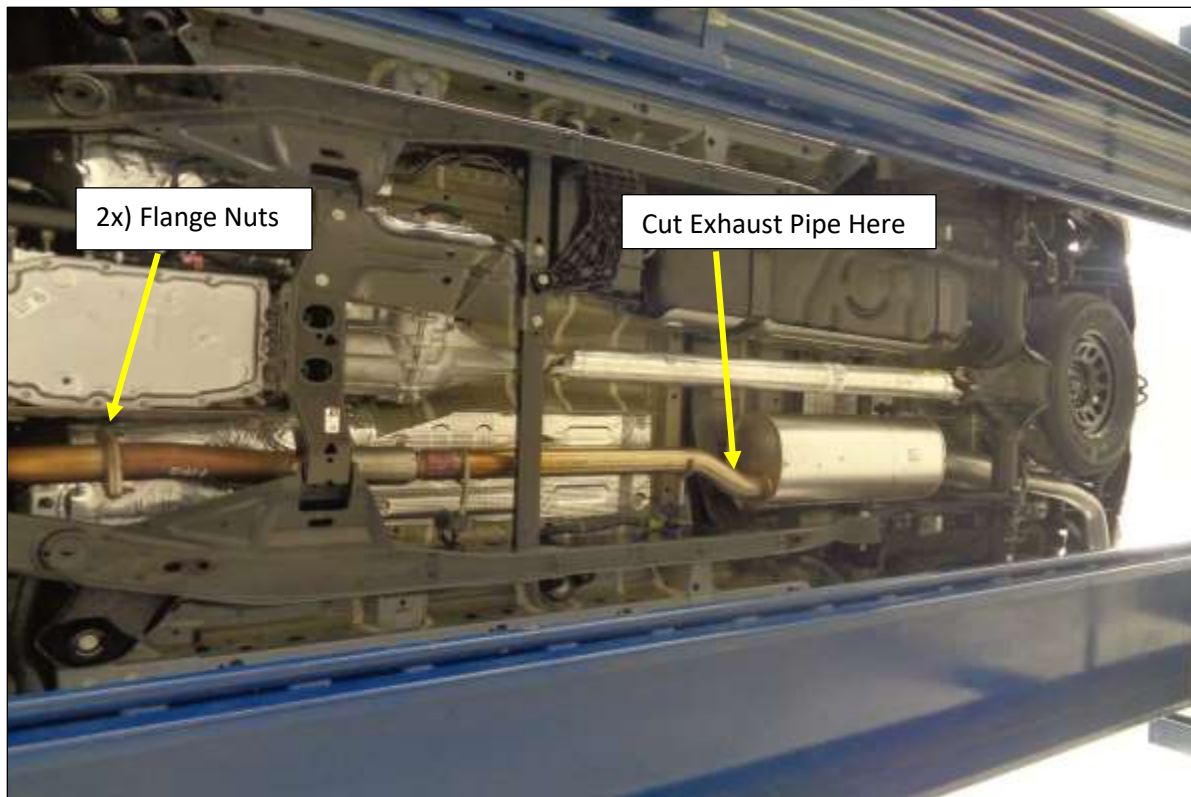

Figure 1

INSTALL YOUR FLOWMASTER EXHAUST SYSTEM



Before installing clamps in the following steps, remove their nuts, apply anti-seize compound to the bolt threads, and re-install the nuts.

Repositioning the spare tire heat shield $\frac{3}{4}$ " towards the driver's side of the vehicle will be necessary to gain the required clearance for the tailpipe between the leaf spring and heat shield. Follow the simple steps below to locate the new mounting holes for the heat shield bolts.

1. Remove the spare tire.
2. Mark the mounting bolt centerline on the three heatshield mounting bolts before removing the heatshield. Keep the centerline of the bolts on the centerline of the crossmember. **Fig. 2**
3. Remove the heatshield.
4. Measure $\frac{3}{4}$ " from the edge (not the center) of the existing mounting hole and make a witness mark across the marks made on the centerline. **Fig. 3**
5. Drill a $\frac{1}{2}$ " hole at the intersection of the two witness lines. **Fig. 3**
6. Reinstall the spare tire heat shield using the new mounting holes **Fig. 4** Reinstall the spare tire.



Figure 2

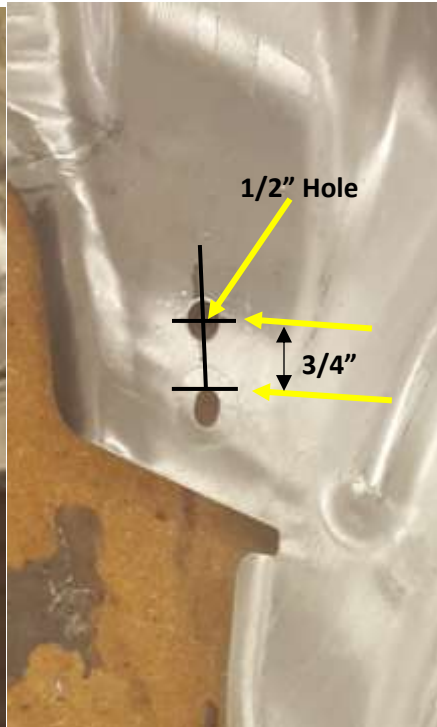

Figure 3

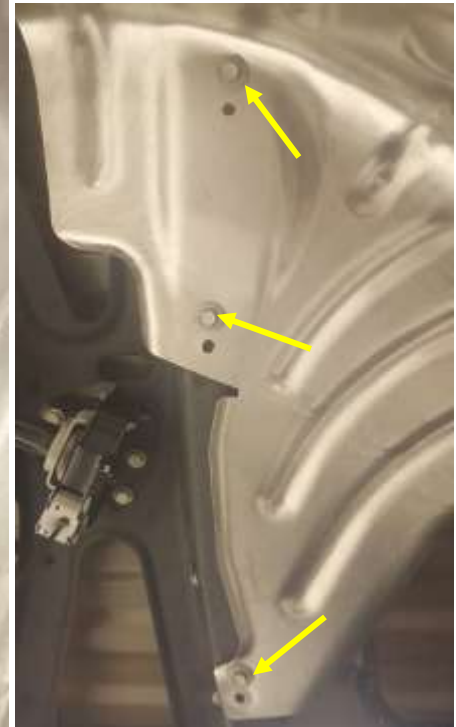

Figure 4

Exhaust Installation Continued

7. Reinstall the (x5) rubber hanger rod isolators on to the vehicle if they were removed.
8. Install the Flowmaster Muffler inlet pipe (1) into the vehicle and on to the studs at the catalytic converter 2-bolt flange. **Fig. 5**
9. Install the hanger rods into the isolators. **Fig. 5**
10. Install the (x2) 15mm nuts on to the studs at the 2-bolt flange and tighten. **Fig. 5**

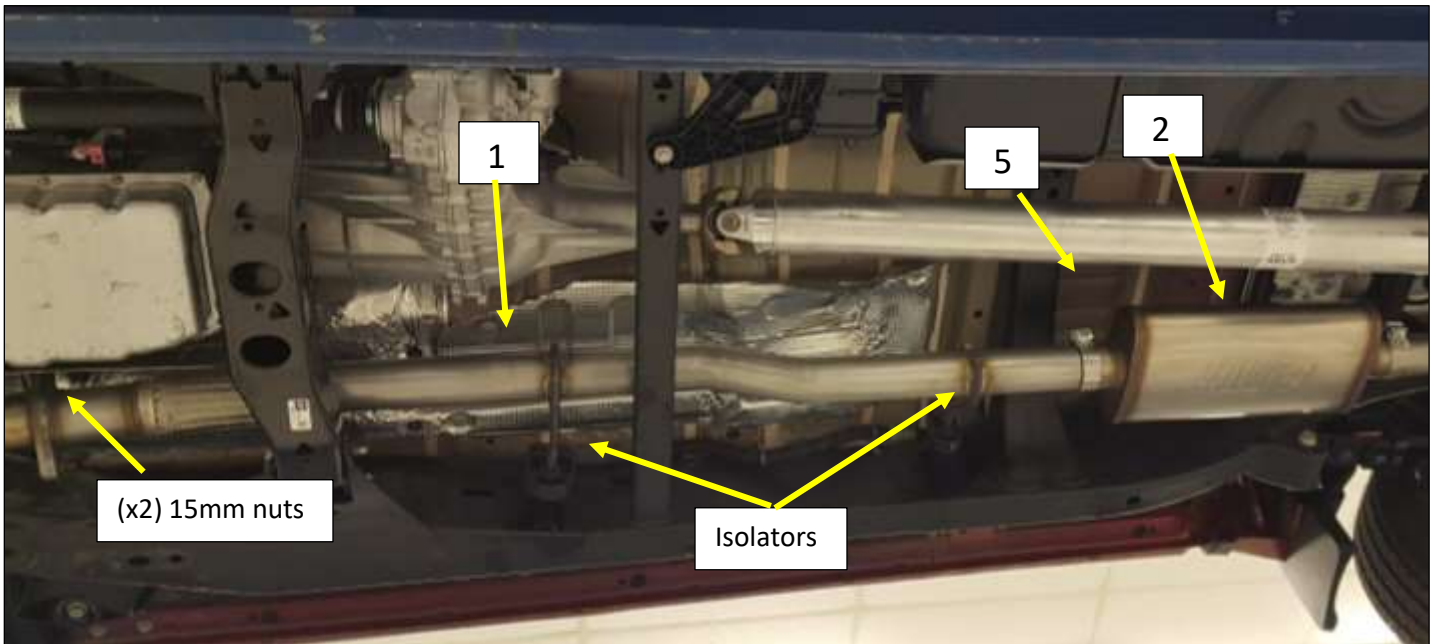

Figure 5

11. Install a supplied 3.0" band clamp (5) on to the muffler inlet with the bolt at the top and the nut facing the ground. **Fig. 5**
12. Install the muffler (2) on to the muffler inlet pipe (1) and level with the ground and Flow FX Logo running front to back. Tighten the clamp to allow for adjustment. Support the muffler with a jack stand. **Fig. 5**

Installation Exhaust Continued

13. Install a supplied 3.0" band clamps (5) on to the muffler outlet with the bolt at the top and the nut facing the ground. Do not tighten. **Fig. 6**
14. Install the muffler outlet pipe (3) into the muffler outlet. Install the hanger rod into the isolators over the muffler and tighten the clamp to allow for adjustment. **Fig. 6**

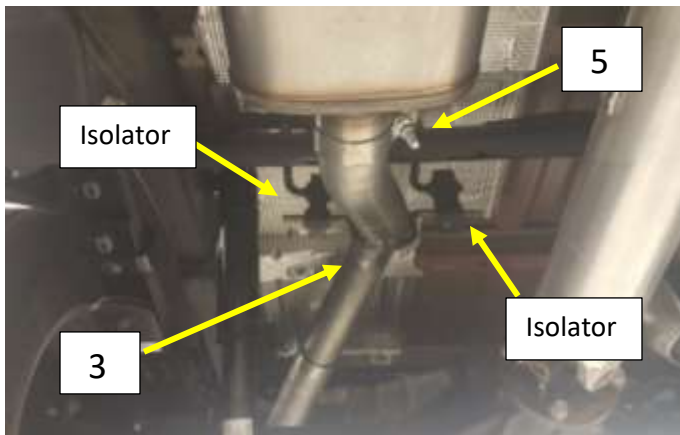

Figure 6

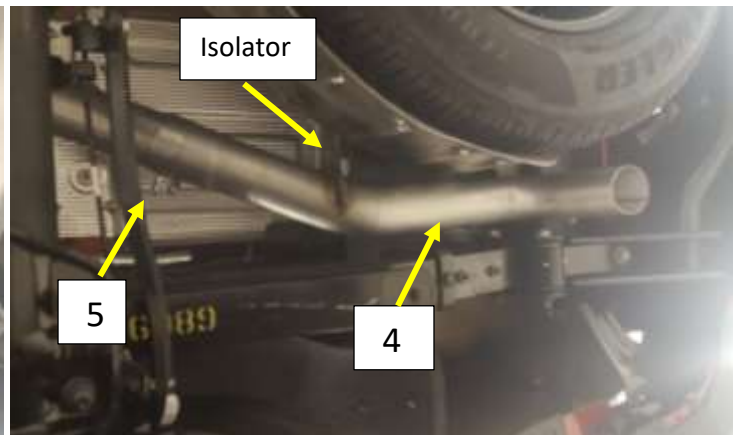

Figure 7

15. Install a supplied 3.0" band clamp (5) onto the expanded end of the turn down tailpipe (4) with the bolt at the top and the nut facing the ground. **Fig. 7**
16. Install the tailpipe on to the muffler outlet pipe and install the hanger rod into the isolator. **Fig. 5**
17. Start at the front of the vehicle and adjust the system for best alignment and clearance. Tighten the clamps as you go. Make final adjustments and re torque the clamps and check all fasteners after the first test drive.
18. Install the push clips on the hanger rods to prevent the system from moving.



Enjoy Your Flowmaster Exhaust!