



Installation diagram for:  
**SYSTEM #817612**  
 2013-2014 FORD MUSTANG GT500  
 5.8L · V8 ENGINE



**409S, Stainless Steel**

**PACKING LIST**

<u>Qty</u>	<u>Description</u>	<u>Part #</u>
1	Left Muffler	8430012-340
1	Right Muffler	8430012-341
4	Stainless Tip	ST470
1	Parts kit	PK764
4	2½" Band Clamps	MC250BS
2	3/8" Hanger Keepers	HW501

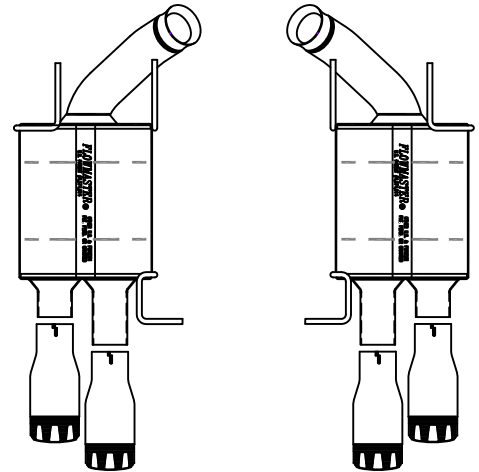

02/18/14

**Removal:**

- 1) Loosen the 13mm nuts on the clamped connections between the mufflers and the over-axle pipes. The bolts need to be backed out to the end of the threads in order to open the clamp enough to allow the flared ball connection of the inlet pipe to be removed.
- 2) There are three hangers on each muffler, two in the front and one in the rear. Separate the rear hanger rods from the rubber mount first, and slide the muffler forward and out of the front mounts. A silicone spray lubricant will help the hangers to slip out.
- 3) The factory clamps will be used to install the new mufflers however they are fastened to the original mufflers with a small tab and will need to be removed. This can be accomplished by wiggling the clamp back and forth to break the tab.

**Installation:**

- 1) Place the factory clamps removed in the previous step, onto the inlet pipes of the new mufflers. Slide the forward hanger rods into the rubber mounts, and then secure the rear hanger rod. Now the ball connection on the inlet pipe can be connected to the over-axle pipe. Level the muffler and tighten the clamp on the muffler enough to hold in position.
- 2) Place a provided 2½" clamp onto each of the muffler outlets, and then place the stainless tips onto the muffler outlets and adjust to the desired location. We designed the system with clamp-on tips so that you can adjust to your preferred look. They can be installed in a staggered fashion with a straight up rotation, or they can be rolled over to provide a slanted look similar to the original tips. After achieving the desired tip location, securely tighten down the clamps on the tips.
- 3) Now go back and check the alignment of the system and make any necessary adjustments. A minimum of ½" clearance around all parts of the system must be maintained; while keeping suspension travel and vibration in mind. After adjustments have been made, securely tighten all the clamped locations and place the push on retainers onto the rear hanger rods to prevent them from slipping out of the rubber mounts.