

MSD INSTALLATION INSTRUCTIONS

MSD Billet Crank Trigger Distributors PN 8489/84893 and PN 8486/84863

ONLINE PRODUCT REGISTRATION: Register your MSD product online. Registering your product will help if there is ever a warranty issue with your product and helps the MSD R&D team create new products that you ask for! Go to www.msperformance.com/registration.

Note: Read these instructions completely before attempting the installation.

Parts Included:

- 1 - MSD Distributor Assembly
- 2 - O-Rings
- 1 - Tube of Gear Lubricant
- 1 - Slip Collar

Replacement Parts:

- Rotor, PN 8567
- Rotor Base, PN 8568
- Crab Cap, PN 8541, PN 85413
- Standard Bronze Gear (0.500" ID), PN 8471
- Oversize (0.006") Bronze Gear (0.500" ID), PN 8472

WARNING: During installation, disconnect the battery cables. When disconnecting the cables, always remove the Negative cable first and install it last.

Note: A Crank Trigger must be used with this distributor.

An MSD Billet Hold-Down Clamp, PN 8110, is recommended.

O-RING SEALS

The MSD Billet Distributor features two O-ring grooves in the bottom lands of the housing to seal the oil gallery. These O-rings should only be installed if the block has been modified as shown in Figure 1.

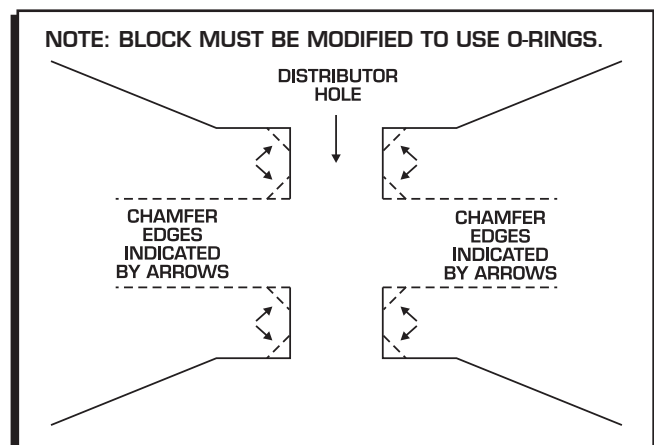

Figure 1 Modified Block to Accept the O-Ring Seals.

REMOVING THE DISTRIBUTOR

1. Remove the existing distributor cap without disconnecting any of the spark plug wires.
2. With the cap off, rotate the engine or until the rotor is aimed at a fixed point on the engine or firewall. Note this position by making a mark (Figure 2).
3. Place the distributor cap back on and note which plug wire the rotor is pointing to. MARK THE SPARK PLUG WIRES and remove the distributor cap.
4. Loosen the distributor hold-down clamp and slide the clamp out of the way.
5. Lift the distributor out of the engine. Note that the rotor rotates as you lift the distributor out. This is due to the helical cut gear and should be taken into consideration when installing a new distributor.

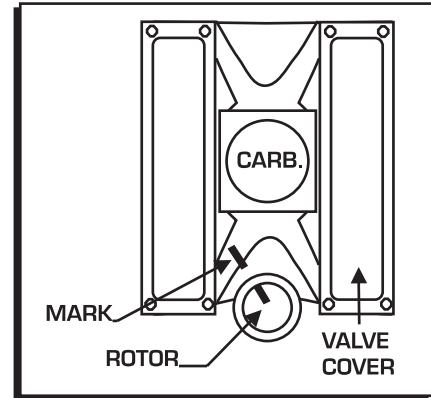

Figure 2 Marking the Rotor Location.

PREPARING THE DISTRIBUTOR

The MSD Billet Distributor features an adjustable slip collar. This collar provides an adjustment to accommodate variations in block height, modified intakes or heads. It is recommended to check the slip collar setting before installation. MSD offers a special tool, the 3-In-1 Distributor Set Up Tool, PN 8599, to make these adjustments accurately. If the tool is not available, follow this procedure.

ADJUSTING THE SLIP COLLAR

1. Loosen the slip collar and insert the distributor into the engine until it bottoms out against the oil pump drive.
2. After it bottoms out, raise the distributor 0.010" - 0.030" then slide the slip collar down into the position and tighten it.

CHECKING THE OIL PUMP TO DISTRIBUTOR SHAFT OVERLAP

The proper overlap between the distributor shaft and the oil pump shaft is very important. The tongue of the distributor shaft should fit into the groove of the oil pump shaft by at least 1/4". To check this:

CHECKING GEAR MESH

1. Measure the distance between the base of the slip collar to the tip of the distributor shaft (Figure 3).
2. Using a straight edge, measure the distance from the intake manifold distributor flange to the top of the oil pump intermediate shaft (Figure 3).
3. Take the two measurements and subtract them. The difference is the overlap. If there is not enough clearance or too much clearance, a different oil pump shaft is required.

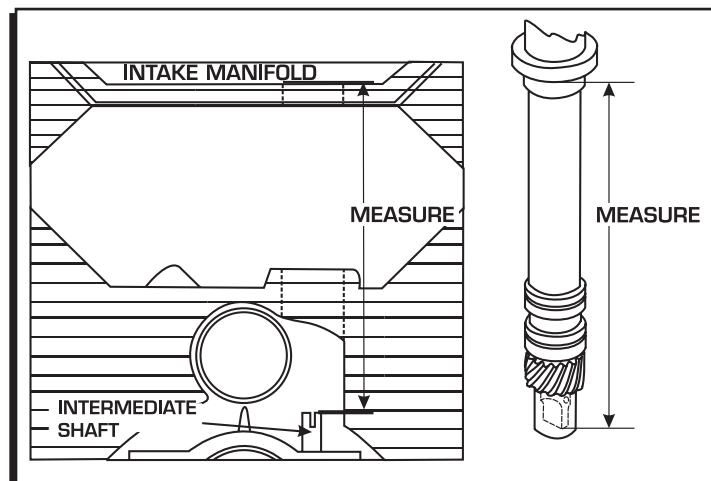

Figure 3 Checking Oil Pump Shaft to the Distributor Shaft Overlay.

