



ULTRA-SEAL HEAD GASKETS

Installation Instructions

IMPORTANT NOTE: Do not use any type of glue or sealant on this head gasket. The special coating used on the gasket are all that is needed to properly seal all fluid passages and minor imperfections.

- Place straight edge across head and block surfaces. Surface flatness should not vary more than .0025"-.0030".
- Follow factory recommended torque sequence.
- Attaining proper clamp load is one of the most important steps to a successful seal.
- If old bolts or studs are being reused, thoroughly clean threads to ensure accurate torque reading.
- Tighten in at least three steps.
- Move torque wrench in a smooth, easy motion.
- Use hardened washers to further reduce friction and increase torque accuracy.
- Use Earl's thread sealant # D024ERL on bolts holes that enter cooling passages.
- If engine is disassembled, run tap through all holes.
- Torque specs will vary with type of lubrication used. Use anti-seize or fresh engine oil – per the bolt / stud manufacturer's recommendation.

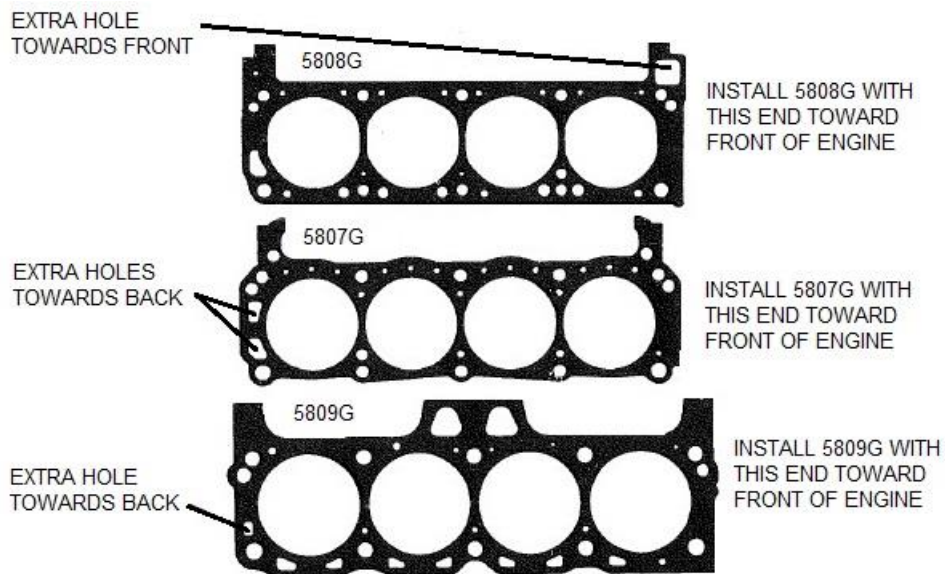

Technical Support: 1-866-464-6553

97140221

Date: 7-17-17