



P/N A5130-SNOS

302 Ford SFI

Kit Numbers: 05115NOS

OWNER'S MANUAL

NOTICE: Installation of Nitrous Oxide Systems Inc. products signifies that you have read this document and have agreed to the terms stated within.

It is the purchaser's responsibility to follow all installation instruction guidelines and safety procedures supplied with the product as it is received by the purchaser to determine the compatibility of the product with the vehicle or the device the purchaser intends to install the product on.

Nitrous Oxide Systems Inc. assumes no responsibility for damages occurring from accident, misuse, abuse, improper installation, improper operation, lack of reasonable care, or all previously stated reasons resulting from incompatibility with other manufacturers' products.

Nitrous Oxide Systems Inc. assumes no responsibility or liability for damages incurred by the use of products manufactured or sold by Nitrous Oxide Systems Inc. on vehicles used for competition or racing.

Nitrous Oxide Systems Inc. neither recommends nor condones the use of products manufactured or sold by Nitrous Oxide Systems Inc. on vehicles, which may be driven on public roads or highways, and assumes no responsibility for damages incurred by such use.

NOS nitrous oxide is legal for use in most states when used in accordance with state and local traffic laws. NOS does not recommend or condone the use of its products in illegal racing activities.

NOTICE: The NOS Kit Number 05115NOS is not intended for use on hatchback type vehicles without the use of NOS P/N 16160NOS (External Aluminum Blow-Down Tube) and 16169NOS (Racer Safety Blow-Off Adapter).

HAZARDS DEFINED

This manual presents step-by-step instructions that describe the process of installing your NOS Nitrous Oxide Injection System. These procedures provide a framework for installation and operation of this kit. Parts are referenced by name and number to avoid confusion. Within the instructions, you are advised of potential hazards, pitfalls, and problems to avoid. The following examples explain the various hazard levels:

WARNING! Failure to comply with instructions may result in injury or death.

CAUTION! Failure to comply with instructions may result in damage to equipment.

NOTE: This information is important, needs to be emphasized, and is set apart from the rest of the text.

HINT: These special instructions provide a handy work tip.

NITROUS OXIDE INJECTION SYSTEM SAFETY TIPS

WARNINGS

Do not attempt to start the engine if the nitrous has been injected while the engine was not running. Disconnect the coil wire and turn the engine over with the throttle wide open for several revolutions before attempting to start. Failure to do so can result in extreme engine damage.

Never permit oil, grease, or any other readily combustible substances to come in contact with cylinders, valves, solenoids, hoses, and fittings. Oil and certain gases (such as oxygen and nitrous oxide) may combine to produce a highly flammable condition.

Never interchange nitrous and fuel solenoids. Failure to follow these simple instructions can result in extreme engine damage and/or personal injury.

Never drop or violently strike the bottle. Doing so may result in an explosive bottle failure.

Never change pressure settings of the safety relief valve on the nitrous bottle valve. Increasing the safety relief valve pressure settings may create an explosive bottle hazard.

Identify the gas content by the NOS label on the bottle before using. If the bottle is not identified to show the gas contained, return the bottle to the supplier.

Do not deface or remove any markings that are on the nitrous bottle.

Nitrous bottle valves should always be closed whenever the system is not being used.

Notify the supplier of any condition, which might have permitted any foreign matter to enter the valve or bottle.

Keep the valves closed on all empty bottles to prevent accidental contamination.

After storage, open the nitrous bottle valve for an instant to clear the opening of any possible dust or dirt.

It is important that all threads on the valves and solenoids are properly mated. Never force connections that do not fit properly.

CONGRATULATIONS on purchasing your NOS Nitrous Oxide Injection System. Your system is composed of the highest quality components available. It should provide many miles of trouble-free performance when used correctly. If you have any questions regarding the performance of your system, call NOS Technical Service at 1-866-GOHOLLEY.

WHAT IS NITROUS OXIDE?

NITROUS OXIDE...

...Is a cryogenic gas composed of nitrogen and oxygen molecules

...Is 36% oxygen by weight

...Is non-flammable by itself

...Is stored as a compressed liquid

...Exists in two grades—U.S.P. and Nitrous Plus:

- U.S.P. is medical grade nitrous oxide; its common use is dental and veterinary anesthesia. It is also commonly used as a propellant in canned whipped cream. U.S.P. is not available to the public.
- Nitrous Plus differs from U.S.P. in that it contains trace amounts of sulphur dioxide added to prevent substance abuse. Nitrous Plus is intended for automotive applications and is available for sale to the public

In automotive applications, Nitrous Plus and fuel are injected into the engine's intake manifold, which produces the following results:

- Lowers engine intake air temperature, producing a dense inlet charge.
- Increases the oxygen content of the inlet charge (air is only 22 percent oxygen by weight).
- Increases the rate at which combustion occurs in the engine's cylinders.

Do's and Don'ts of Nitrous Oxide

Do's

- Read all instructions before attempting to install your NOS nitrous system.
- Make sure your fuel delivery system is adequate for the nitrous jetting you have chosen. Inadequate fuel pressure or flow will result in engine damage.
- Use 14 gauge (minimum) wire when installing electrical system components.
- Use high-quality connections at all electrical joints.
- Use PTFE-based paste on pipe style fittings.
- Make sure your engine and related components (ignition, carburetor, and driveline) are in proper working condition.
- If nitrous is accidentally injected into the engine when it is not running, remove the engine coil wire, open the throttle, and crank the engine 10 to 15 seconds before starting. Failure to do so can result in an explosive engine failure.**
- Use your NOS nitrous system at wide-open throttle only and at engine speeds above 3000 RPM.**
- Install a proper engine to chassis ground. Failure to do so may result in an explosive failure of the main nitrous supply line.**
- Use a high-quality fuel, as suggested in Chapter 3, Baseline Tuning Suggestions.

Don'ts

- Engage your nitrous system with the engine off. Severe engine damage can occur.
- Modify NOS nitrous systems (if you need a non-stock item, call NOS Technical Service for assistance)
- Overtighten AN type fittings.
- Use PTFE Tape on any pipe threads. Pieces of PTFE tape can break loose and become lodged in nitrous or fuel solenoids or solenoid filters. Debris lodged in a nitrous or fuel solenoid can cause catastrophic engine failure.

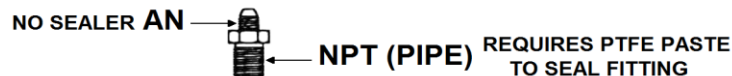

- Use sealant of any kind on AN type fittings.
- Allow nitrous pressure to exceed 1100 psi. Excessive pressure can cause swelling or in extreme cases failure of the nitrous solenoid plunger. Solenoid plungers are designed so that pressure-induced failures will prevent the valve from operating. No leakage should occur with this type of failure.
- Inhale nitrous oxide. Death due to suffocation can occur.**
- Allow nitrous oxide to come in contact with skin. Severe frostbite can occur.**
- Use octane boosters that contain methanol. Fuel solenoid failure may occur, producing severe engine damage.**

Chapter 1 Introduction to your NOS Nitrous Oxide Kit

1.1 General Information

Kit Number 05115NOS is intended for use on 1986-1991 302 Ford SFI engines. Power output is increased by approximately 80 HP, and torqued by 70 to 80 ft./lb. over stock.

NOTE: Nitrous oxide injection systems that add fuel near the throttle body (wet style) on 5.0L Fords are prone to poor mixture distribution and fuel puddling in the intake manifold, thus frequently causing severe intake manifold backfires.

Kit Number 05115NOS flows all fuel through the Ford injectors. Necessary fuel flow is accomplished by increasing the fuel pressure and fuel flow rate.

Table 1 Jetting and Power Levels

Kit Number	Jetting N ₂ O/Bypass	Approximate Power Gain	Approximate N ₂ O Consumption Rate
05115NOS	47/59	80 HP	0.9 lbs./10 sec.

Typically the standard #10 (10 lb.) bottle of nitrous will supply 1 1/2 to 2 minutes of operation at wide-open throttle. A full #10 bottle will weigh 25 lbs. For best performance, the bottle should be refilled when it weighs 17 to 18 lbs.

NOTE: Kits 05115NOS may be used on other vehicles. Contact NOS Technical Support at 1-866-GOHOLLEY for jetting suggestions before attempting to install Kit Number 05115NOS on engines other than the 302 Ford SFI.

1.2 System Requirements

When used correctly, Kit Number 05115NOS is designed to work with stock Ford internal engine components. The following are suggested to ensure proper performance and driveline longevity:

- **Automatic Transmissions**
The stock Ford "AOD 4" automatic transmission is marginal for high-performance use and should be prepared by a reputable high-performance transmission shop before being subjected to severe use.
- **Manual Transmissions**
The standard Ford clutch is acceptable for use with the base Number 05115NOS kit.

1.3 Kit Components

Before beginning the installation of your NOS kit, compare the components in your kit with those shown in Figure 1, and listed in Table 2. If any components are missing, please contact NOS Technical Service at 1-866-464-6553.

Table 2 Kit Number 05115NOS Parts List

Item	Description	Quantity	NOS P/N
(1)	Bottle 10 lb.	1	14745NOS
(2)	Bottle Valve Washer	1	16210NOS
(3)	Bottle Valve Adapter	1	16220NOS
(4)	Bottle Bracket Set	1	14125NOS
(5)	Main N ₂ O Feed Line 4AN 14 ft.	1	15295NOS
(6)	Nitrous Filter	1	15570NOS
(7)	Nitrous Solenoid	2	16020NOS
(8)	Nitrous Solenoid TEE	1	17242NOS
(9)	Solenoid Mounting Bracket	1	16509NOS
(10)	1/8" NPT Male x 1/8" NPT Nipple	1	17500NOS
(11)	Nitrous Regulator	1	15850NOS
(12)	3 AN Hose w/ 1/8" NPT Male Fitting	1	15060-1NOS
(13)	#42 Flare Jet	1	13750-42NOS
(14)	Fan Spray Nozzle	1	13500NOS
(15)	1/8" NPT x 3/16" Hose Barb Fitting	1	16244-A-SNOS
(16)	Ratcheting Hose Clamps	4	36R1023-1
(17)	Vacuum Hose	1	15005-SNOS
(18)	Vacuum Hose TEE	1	17538-59-SNOS
(19)	Microswitch	1	15640NOS
(20)	Wiring Relay—30 Amp	1	15618NOS
(21)	Arming Switch*	1	15602NOS
(22)	Harness for Wiring Relay**	1	15604-SNOS
(23)	Fuel Pressure Safety Switch	1	15685NOS
(24)	4 AN x 4 AN 90° Fitting (for optional use)	1	17535NOS
(25)	1/16" NPT x 1/8" NPT Adapter	1	16785NOS
(26)	1/16" NPT Tap	1	15990NOS

*Wiring, connectors, and inline fuse also supplied.

**Part not shown on Figure 1.

Figure 1 Kit Number 05115NOS Components

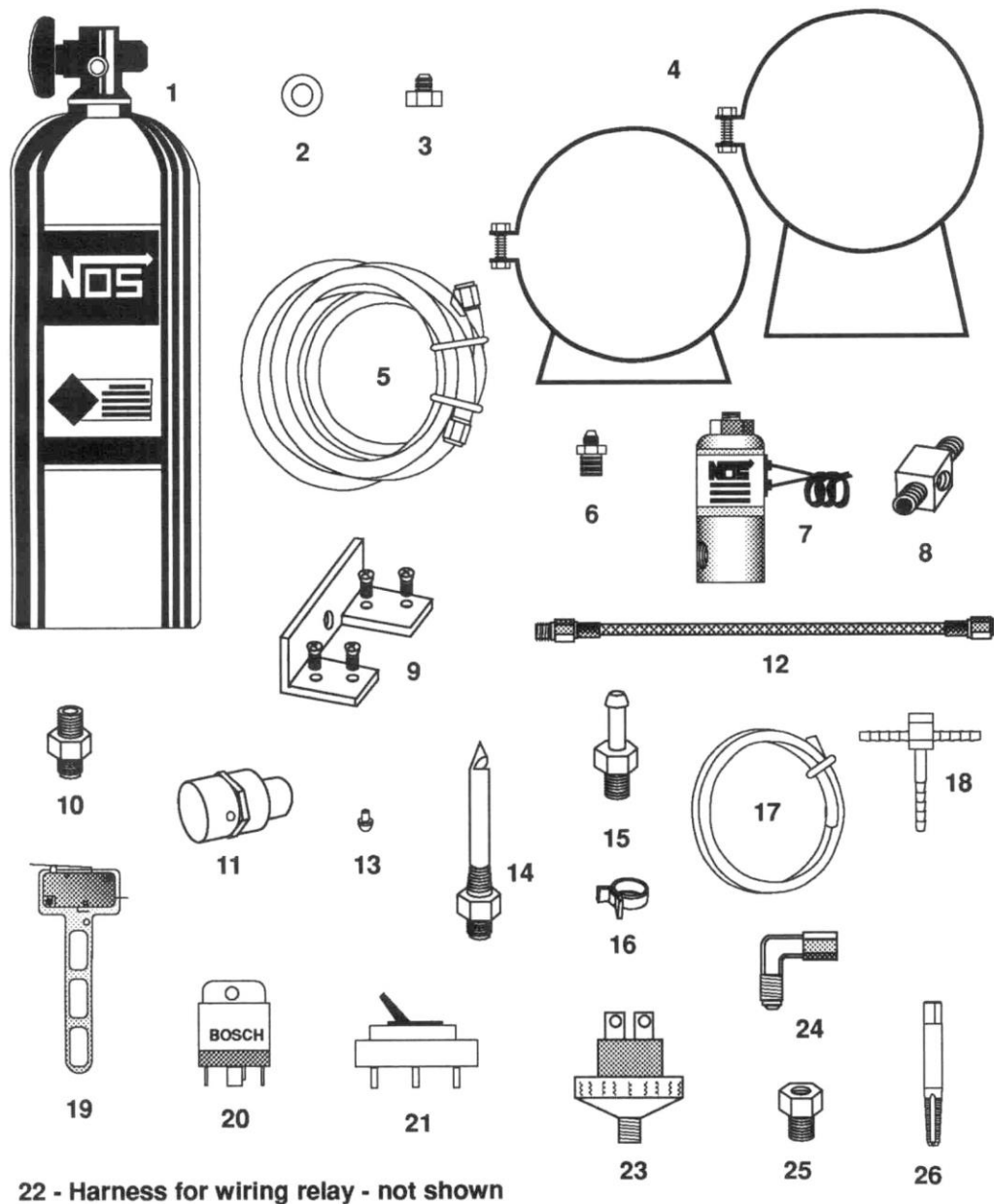

Chapter 2 Kit Installation

2.1 Bottle Mounting Instructions

NOTE: Disconnect the battery ground before beginning installation.

2.1.1 Street Vehicles

Accurate calibration of your NOS nitrous system depends on the bottle remaining at a stable temperature. Mount the bottle away from heat sources, such as the engine compartment or exhaust system, and away from windows, where the bottle is exposed to direct sunlight.

NOS recommends that the bottle be environmentally separated from the driver's compartment. Because hatchback-type vehicles generally do not have a firewall between the trunk area and the driver's compartment, the safety pressure relief cap should be replaced with P/N 16169NOS, and P/N 16160NOS should be added. P/N 16160NOS is an aluminum blow-down tube (an -8 neoprene-lined braided hose can be substituted). The blow-down tube should be routed to the exterior of the vehicle (preferably under the vehicle). This procedure will prevent filling the driver's compartment with a cloud of nitrous oxide if the safety pressure relief cap should rupture for any reason.

2.1.2 Racing Vehicles

Before mounting a nitrous bottle in a racing vehicle intended for use in sanctioned events, check with the sanctioning association for any rules regarding this subject. Most associations require the bottle to be mounted within the confines of the safety roll cage, with the safety pressure relief cap vented away from the driver's compartment.

Figure 2 Nitrous Bottle Siphon Tube Orientation

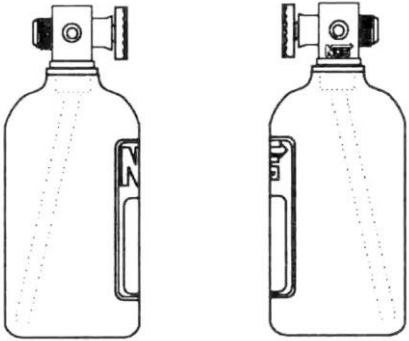
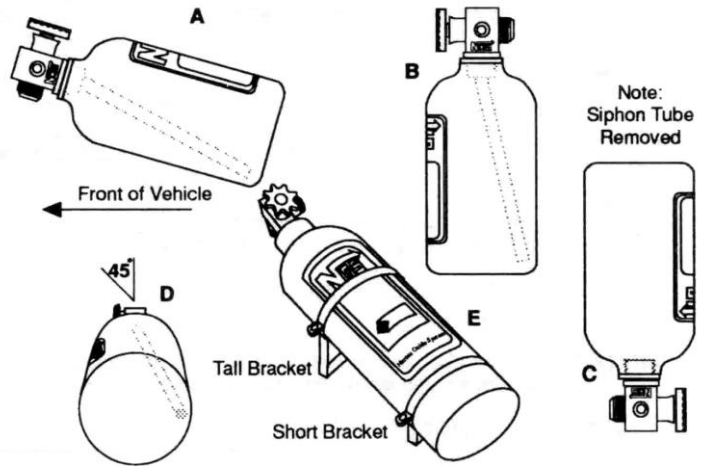

Figure 3 Nitrous Bottle Mounting Orientations



2.2 Bottle Orientation

Bottle placement is critical to the performance of your NOS nitrous system. It is important to understand how the bottle valve and siphon tube are assembled to properly orient the bottle in your vehicle and ensure that it picks up liquid nitrous while undergoing acceleration. All NOS bottles are assembled so that the bottom of the siphon tube is at the bottom of the bottle and opposite the bottle label (Figure 2).

Whenever the bottle is mounted in a lay-down position, the valve handle must be towards the front of the vehicle with the label facing up (Figure 3A).

If the bottle is mounted vertically, the valve handle and label must face toward the front of the vehicle (Figure 3B). This orientation will position the siphon tube at the back of the bottle where the liquid N₂O will be during acceleration.

WARNING! DO NOT attempt to remove the siphon tube without completely emptying the bottle of all nitrous and pressure.

A bottle mounted upside-down must have the siphon tube removed before use (Figure 3C). Non-siphon bottles can be specially ordered from NOS. If the bottle must be mounted parallel to the axles of the vehicle (sideways), the valve handle and label must be angled at approximately 45° toward the front of the vehicle (Figure 3D). This orientation will position the siphon tube toward the rear of the bottle.

NOTE: When using a bottle with a siphon tube, the tall bracket should be at the valve end of the bottle and the short bracket at the bottom (Figure 3E).

The most efficient mounting is the lay-down position (Figure 3A) with the valve handle toward the front of the vehicle. This position allows the greatest amount of liquid to be used before the siphon tube begins to pick up gaseous nitrous oxide.

2.3 Bottle Installation

After you have determined the location and orientation of the nitrous bottle, use the following procedure to install the bottle:

NOTE: Numbers in parentheses () refer to the parts list /assembly drawing number for the component (Figure 1). Figure 4 shows the installation assembly for Kit Number 05115NOS.

Figure 4 Kit Number 05115NOS Assembly Drawing

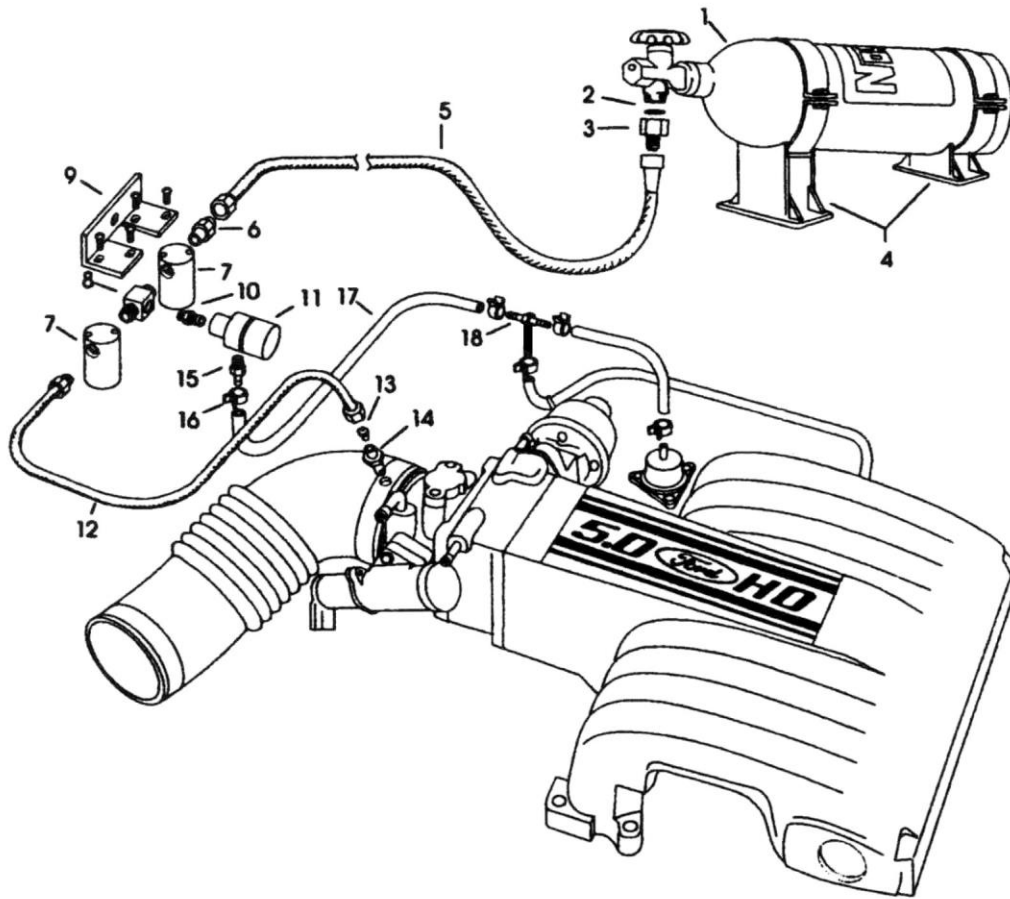

1. Install the bottle nut adapter (3) and washer (2) on the nitrous bottle (1), and tighten securely.
2. Loosely install the bottle mounting brackets (4) on the nitrous bottle.
3. Locate the bottle assembly in the desired mounting location, ensuring that the location will provide easy access to the bottle valve, hose connection, and bracket clamp bolts to facilitate bottle changing.
4. Use the assembled bottle/bracket/blow-down tube unit as a pattern to mark for hole drilling. Drill four 5/16" holes for the bottle bracket bolts, a 1/2" hole for the blow-down tube, and an 11/16" hole for the nitrous supply tube.
5. Mount the brackets securely to the surface (recommended minimum of 5/16" bolts).
6. Tighten the bracket clamps on the bottle.

2.4 Spray Nozzle Installation

1. Find a suitable location for the fan spray nozzle in the intake throttle body. Check for interference between the spray nozzle and hood or nearby components. Make sure the nozzle does not contact the hood when closed.
2. Remove the rubber air inlet duct and clamp from the throttle body. Place a rag in the throttle body. Reinstall the rubber air inlet duct and clamp.

CAUTION: Debris from drilling can severely damage the engine. When drilling the spray nozzle hole, position the rag carefully to prevent debris from contaminating your engine.

3. Drill a 1/4" hole perpendicular to the throttle body centerline through the clamp, inlet duct, and throttle body.
4. Remove the rubber inlet duct and clamp.
5. Re-drill the holes in the inlet duct and clamp using a 5/16" drill bit.

6. Use a 1/16" NPT Tap (26) to thread the 1/4" throttle body hole.
7. Remove the cloth and **all** debris from the throttle body.
8. Install the rubber inlet duct and clamp assembly.
9. Mark the discharge side of the Fan Spray Nozzle (14).
10. Install the fan spray nozzle into the inlet duct with the nozzle discharge pointed into the engine.

2.5 Solenoid and Regulator Mounting

Use the following procedure to install the nitrous solenoids.

NOTE: If you are also installing NOS Kit Number 0015NOS, read Chapter 3 and these instructions before starting.

CAUTION: Do not overtighten the vise in the following procedure, or the solenoid will be damaged.

NOTE: Apply PTFE-based paste to all pipe fittings before assembling the solenoids and regulator.

1. Clamp one nitrous solenoid (7) in a bench vise.
2. Thread one side of the solenoid TEE (8) into the solenoid outlet port. The female 1/8" NPT port should be facing outward, as shown in Figure 4.
3. Thread the open side of the solenoid TEE into the inlet port of the second nitrous solenoid. Rotate the second solenoid, so that it is parallel to the first.
4. Line up the bolt holes on both solenoids with the holes in the solenoid bracket (9).
5. Install the nitrous filter fitting (6) into the first nitrous solenoid inlet port.
6. Install the 1/8" NPT nipple (10) into the nitrous pressure regulator (11) inlet port.
7. Loosely thread the nitrous pressure regulator/nipple assembly into the solenoid TEE open port. If the regulator interferes with the solenoid coils, the coils may be temporarily removed.
8. Thread the 1/8" NPT-to-3/16" hose barb fitting (15) into the regulator.
9. Attach the solenoid mounting bracket (9) to the nitrous solenoids.
10. Thread the 3 AN line male fitting (12) into the second nitrous solenoid outlet port.
11. Remove the assembly from the bench vise.
12. Ensure that the 2 ft. 3 AN nitrous fee line (12) provided will reach the nitrous nozzle from the mounting location on the driver's side inner fender.
13. Attach the nitrous solenoid/bracket assembly to the passenger's side inner fender.

NOTE: It is best to mount the solenoid assembly in a location that minimizes the distance from the nitrous regulator to the fuel pressure regulator.

14. Adjust the nitrous pressure regulator so the hose barb fitting points toward the engine fuel pressure regulator.

2.6 Regulator and Fuel Pressure Regulator Connection

1. Remove the vacuum line from the fuel pressure regulator.
2. Install the pressure TEE (18) center leg into the vacuum line. Refer to Figure 5—Pressure TEE Installation.

Figure 5 Pressure TEE Installation

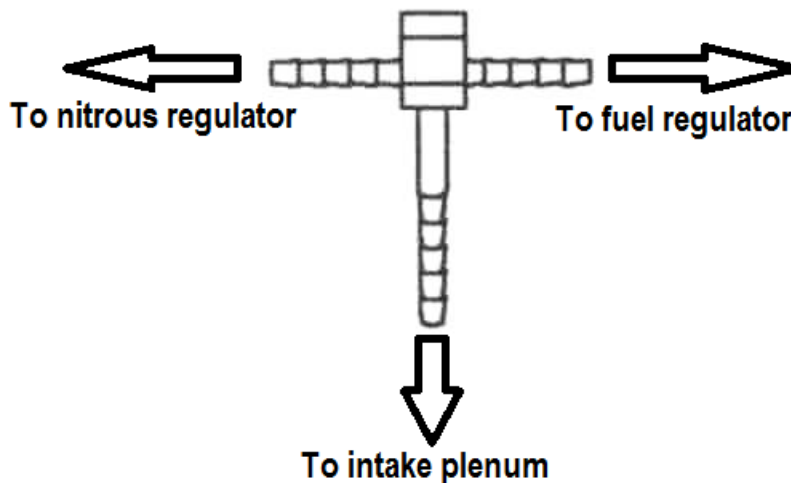

3. Measure and cut a length of vacuum hose (17) to run from one pressure TEE port to the fuel pressure regulator.
4. Measure and cut a length of vacuum hose (17) to run from the remaining pressure TEE open port to the hose barb fitting (15) on the nitrous pressure regulator (11).
5. Clamp the vacuum hose connections using ratcheting hose clamps (16).

2.7 Nitrous Feed Line Mounting

HINT: Most late-model Fords have access plugs in the trunk floor that are convenient for line routing. Following the fuel lines along the underside of the vehicle and entering the engine bay through the front fender well between the plastic inner fender panel and the body usually works well.

1. Determine the route for your nitrous feed line to follow. Ensure the path is clear of exhaust system, suspension, steering, wheels, electrical lines and components, and tires.
2. Feed the main nitrous supply line (5) along the proposed route.
3. If it is necessary to support the nitrous supply line under the vehicle, use 1/2" Tinnerman clamps or nylon tie-wraps to support the line securely.
4. Attach the nitrous supply line to the nitrous bottle valve adapter (3). Use the optional 4 AN to 4 AN 90° fitting (24), if necessary.

WARNING: Nitrous oxide is dangerous to humans if inhaled or comes in contact with the skin. Always point the nitrous line opening away from people when purging the line.

5. Purge the nitrous supply line.
 - A. Wrap the end of the nitrous line with a rag and hold securely.
 - B. Point the opening **away** from people.
 - C. Briefly open the bottle valve.
6. Attach the nitrous supply line to the nitrous solenoid (7) inlet port. Use the optional 4 AN to 4 AN 90° fitting (24), if necessary.

2.8 Solenoid/Fan Nozzle Nitrous Line Connection

1. Place the #42 flare jet (13) in the fan spray nozzle (14) inlet.
2. Connect and tighten the 3 AN line (12) to the spray nozzle inlet.

2.9 Electrical System Installation

Use the following procedure and refer to Figures 6 for the electrical system installation.

WARNING! Death or injury may occur from working on a charged electrical system.

1. Disconnect the car battery.

Figure 6 Wiring Schematic

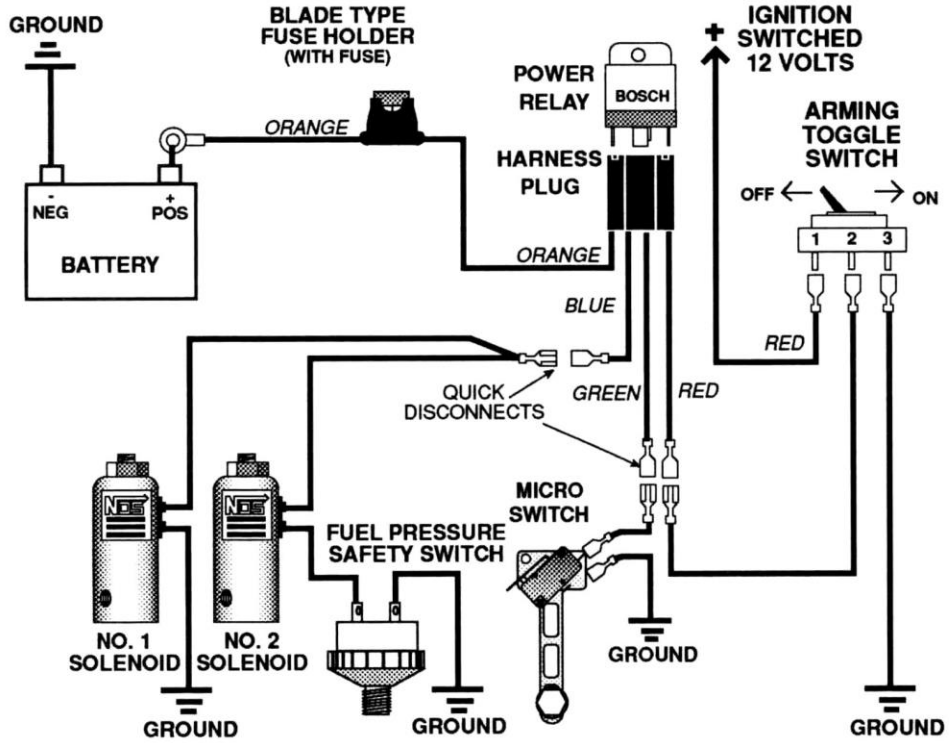
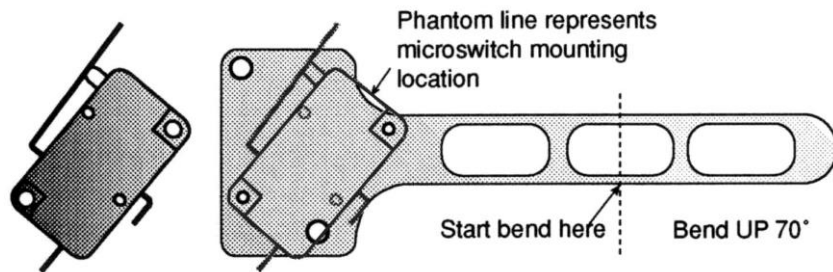
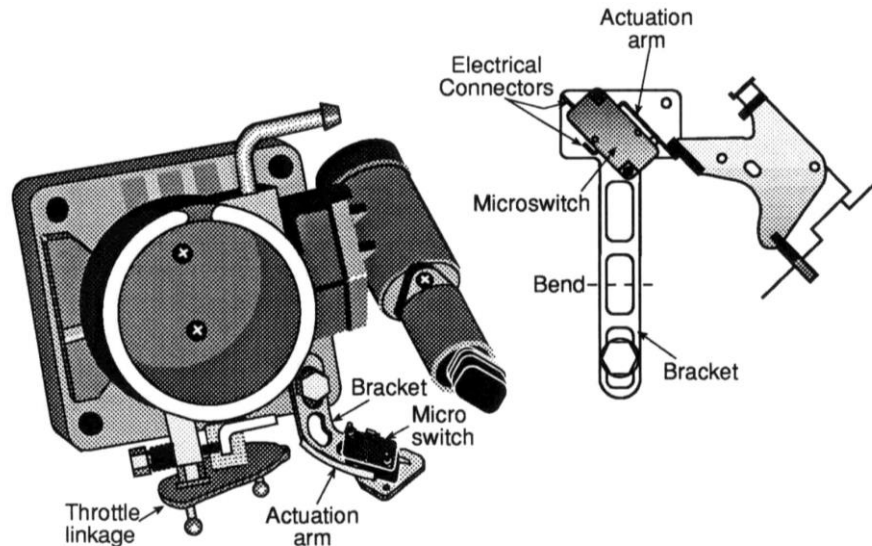

Figure 7 Microswitch Template—Suggested Mounting Configuration



NOTE: The microswitch may be mounted to the bracket in a variety of positions and on either side of the bracket. The bracket may be bent to suit the application.

Figure 8 Microswitch Installation



WARNING! Be careful when removing the fuel rail test port fitting. The fuel rail may be pressurized. Always allow the engine to cool before performing this operation. Fuel sprayed onto hot engine components may start a fire.

2. Remove the fuel rail test port fitting from the fuel rail. Replace the fuel rail test port fitting with the NOS fuel pressure switch (23) using 1/8" NPT x 1/16" NPT adapter (25).
3. Install the microswitch (19) on the throttle body, so the microswitch is triggered by the throttle linkage at wide-open throttle. Figure 7, 8, & 9 show the suggested mounting configuration.

WARNING: Binding or dragging of the throttle linkage will create a potentially dangerous stuck-throttle condition. Ensure that the microswitch does not interfere with the normal throttle linkage operation.

Figure 9 Microswitch Mounting Location

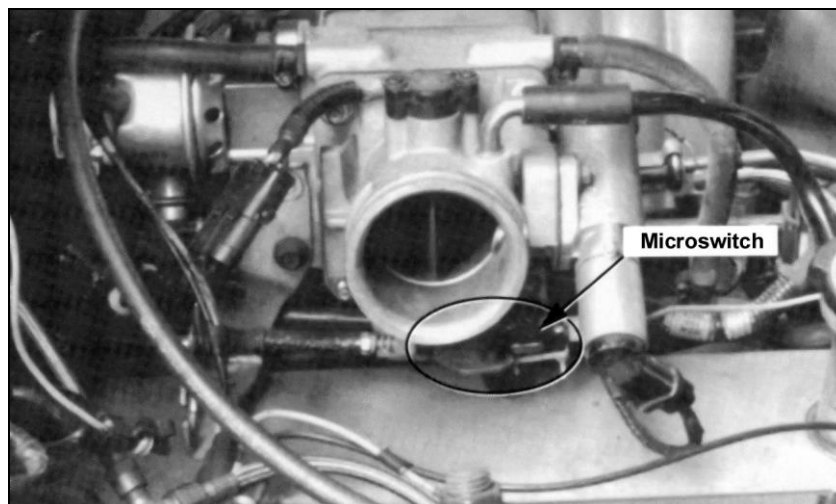

4. Adjust the microswitch to trigger at wide-open throttle. by adjusting the microswitch's position to ensure the actuation arm of the microswitch "clicks" at the same point your throttle linkage reaches WOT against the throttle stop (Position A).
5. Install the NOS arming switch (21) in the vehicle interior, within easy reach of the driver.
6. Install the Wiring Relay (20) in the engine compartment near the battery. The relay's orange wire should reach the battery (+) terminal.
7. Connect the orange relay wire to the battery (+) terminal.
8. Connect one wire from each solenoid together. Join the solenoid wires to the blue relay wire.

9. Connect the remaining first solenoid wire to the ground.
10. Connect the open second solenoid wire to either terminal on the fuel pressure switch.
11. Connect the open terminal on the fuel pressure switch to the ground.
12. Connect the green relay wire to either terminal on the microswitch.
13. Connect the open terminal on the microswitch to the ground.
14. Connect the red relay wire to the middle (#2) terminal on the arming switch (21).
15. Connect the (#1) terminal on the arming switch to the switched 12 volt power source.
16. Connect the (#3) terminal of the arming switch to the ground.
17. Reconnect the battery.

Chapter 3 Baseline Tuning Suggestions

Your NOS Kit Number 05115NOS is factory set to work with stock Ford engine settings. Standard setting combinations are calibrated based upon 900psi bottle pressures. Use of these combinations with lower bottle pressure may produce an excessively rich condition. This can result in a loss of power, or surging.

CAUTION: Use of excessive bottle pressure can result in an excessively lean condition. In extreme cases, this will produce a catastrophic engine failure.

Table 4 Tuning Suggestions for NOS Kit Number 05115NOS

Configuration	N ₂ O Jetting	Fuel Quality	Ignition Timing	Plugs
05115NOS	.042"	92+ Octane	8° BTDC	Stock

Chapter 4 Preparing for Operation

1. Turn the vehicle ignition "ON".
2. Check all fuel and vacuum lines for leaks.
3. Start the engine.
4. Open the nitrous bottle valve.

NOTE: There should be no change in the engine idle speed or exhaust tone. If either change is noted, refer to Appendix A, Troubleshooting Guide.

5. Inspect the nitrous lines and fittings for leaks.
6. ENJOY!!

Chapter 5 Routine Maintenance

5.1 Nitrous Solenoid Filter

When nitrous bottles are refilled they can become contaminated with debris, if the refiller does not have an adequate filter in his transfer pump mechanism. Contaminants in the bottle will eventually become lodged in the nitrous solenoid filter fitting.

You should periodically (after every 20-30 pounds of nitrous usage) examine the mesh in the nitrous filter for debris.

To clean the filter, follow the following steps:

1. Close the valve on the nitrous bottle.

2. Empty the main nitrous feed line.
3. Disconnect the main nitrous feed line from the nitrous solenoid.
4. Remove the nitrous filter fitting from the nitrous solenoid.
5. Remove **all** PTFE paste debris from the solenoid inlet port threads and from the nitrous solenoid filter pipe threads.
6. Examine the mesh in the nitrous filter fitting for contaminants. Blow out debris with compressed air, if necessary.
7. Apply fresh PTFE paste to the nitrous filter pipe threads. Reinstall the filter in the nitrous solenoid.
8. Reconnect the main nitrous supply line to the nitrous solenoid.

5.2 Nitrous Solenoid Plunger

5.2.1 General Information

The seals used in NOS nitrous solenoid plungers are constructed from materials that are designed to be used with nitrous oxide. When kept free from fuel contaminants or from overpressurization, they should provide trouble free performance.

You should periodically (after every 20-30 pounds of nitrous usage) examine the seal in the nitrous solenoid plunger.

The seals used in NOS nitrous solenoid plunger are designed to work at pressures up to 1100 psi. Exposing the plunger to excessive pressure (whether the vehicle is sitting or in-use) can result in the plunger swelling or in extreme cases disintegrating.

NOTE: The seals are designed so that if they fail due to overpressurization, they will not leak, the valve will just fail to flow nitrous oxide.

Swelling of the nitrous solenoid plunger seal will reduce nitrous flow (causing an excessively rich nitrous/fuel condition and a loss of power).

5.2.2 Nitrous Solenoid Plunger Disassembly and Inspection

1. Close the valve on the nitrous bottle.
2. Empty the main nitrous supply line.
3. Remove the retaining nut from the nitrous solenoid.
4. Remove the coil and housing from the nitrous solenoid base.
5. Unscrew the stem from the nitrous solenoid base. Do this by double nutting the stem, or by using a solenoid stem removal tool (NOS P/N 16665-SNOS, included in all overhaul kits). **Do not use pliers on the solenoid stem. Damage to the stem will result.**
6. Remove the stem, spring, and plunger from the solenoid base.
7. Examine the plunger seal for swelling. The seal surface should be flat, except for a small circular indentation in the center of the seal;

A fuel-contaminated seal will protrude from the plunger and be dome-shaped. A fuel-contaminated seal may return to its original shape if left out in the fresh air for several days. It may then be returned to service.

A seal, which has been overpressurized, may be dome-shaped, or the sealing surface may be flat with the seal protruding out of the plunger. A dome-shaped seal may return to its original shape if left out in the fresh air for several days. It may then be returned to service. A seal, which is flat, but protrudes from the plunger body has probably failed internally and should be replaced.

Figure 13 Exploded View of a Typical Solenoid

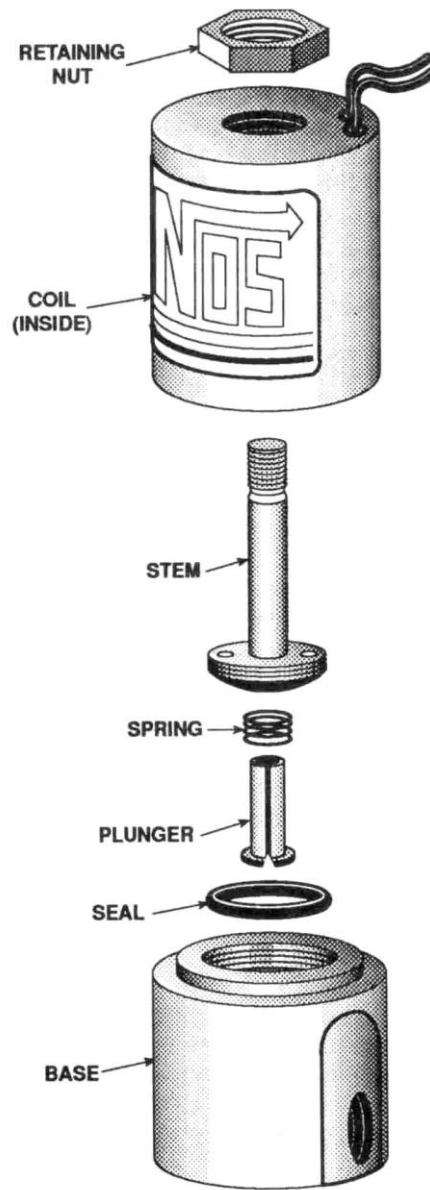

Appendix A Troubleshooting Guide

The troubleshooting chart on the following pages should help determine and rectify most problems with your installed NOS system. If you still need assistance determining or fixing problems, call the NOS Technical Support at 1-866-464-6553.

PROBLEM	POSSIBLE CAUSES	DIAGNOSTIC PROCEDURE	CORRECTIVE ACTION
Engine runs rich when system is activated.	Bottle valve not fully opened.	Check bottle valve.	Open valve fully.
	Plugged nitrous filter.	Inspect filter.	Clean/replace filter.
	Low bottle pressure.	Check bottle temperature.	Set bottle temp. to 75°-85°F.*
	Inadequate nitrous supply.	Weigh bottle.	Fill bottle. 1-800-99-REFILL
	Excessive fuel pressure.	Install fuel pressure gauge, such as NOS P/N 15931NOS in the fuel line. Measure the fuel pressure during acceleration with system activated.	Regulate pressure down, or install a smaller fuel jetting.
	Loose nitrous solenoid wiring.	Inspect the solenoid wiring.	Repair wiring.
	Hobbs switch improperly adjusted or malfunctioning.	Check the switch with 12V test light.	Adjust or replace switch.
	Malfunctioning solenoid.	Disconnect solenoid/injector plug. Connect 12V test light to battery (-) terminal. Turn arming switch ON. Manually set microswitch ON. Use test light probe to check for continuity at blue wire on power relay.	Replace solenoid. *Below 70° F ambient, NOS Bottle Heater #14164 is recommended to maximize performance.
No change in performance when system is activated.	In-line fuse blown.	Check fuse.	Replace fuse.
	System wired incorrectly.	Compare wiring to schematic (Fig. 6).	Wire system per instructions.
	Loose ground wire(s).	Connect 12V test light to battery (+) terminal. Check for continuity at grounds noted in schematic.	Tighten/repair loose grounds.
	Malfunctioning arming switch.	With vehicle ignition ON, turn arming switch ON. Connect 12V test light to battery (-) terminal. Check for power at red wire on arming switch.	Replace arming switch.
	Malfunctioning throttle microswitch.	Temporarily disconnect power relay green wire from microswitch. Connect 12V test light to battery (+) terminal. Manually set microswitch ON. Check for continuity at microswitch positive terminal (Fig. 6).	Replace throttle microswitch.
	Malfunctioning power relay.	Temporarily disconnect solenoid / injector plug. Connect 12V test light to (-) battery terminal. Turn arming switch on. Manually set microswitch on. Use test light to check for continuity at blue wire on power relay.	Replace power relay.
Engine detonates mildly when system is activated.	Excessive ignition timing.	Check ignition timing.	Set timing to factory settings.
	Inadequate octane fuel.		Use higher octane fuel.
	Spark plug heat range too high.		Reduce spark plug heat range (maximum two steps).
	Too much nitrous flow.		Reduce nitrous jetting.
Engine detonates heavily when system is activated.	Inadequate fuel delivery due to: Plugged fuel filter	Inspect fuel filter.	Clean or replace filter.
	Crimped fuel line.	Inspect fuel line.	Replace crimped line.
	Weak fuel pump.	Install fuel pressure gauge, such as NOS P/N 15931NOS. Run engine under load at WOT, with system activated. With Kit 05115NOS, fuel pressure should be at least 38 psi. With Kit 05115-IINOS, fuel pressure should be 80-85 psi.	Repair/replace fuel pump.
High RPM misfire when system is activated.	Excessive spark plug gap.	Inspect spark plugs.	Set spark plug gap at 0.030 to 0.035 inches.
	Weak ignition/ignition component failure.	Inspect components (plug wires, distributor cap, etc.)	Replace worn components.
Surges under acceleration when system is activated.	Inadequate supply of N ₂ O.	Check bottle weight.	Replace with full bottle.
	Bottle mounted incorrectly.	Compare bottle position and orientation to instructions.	Mount or orient bottle correctly.

Nitrous Oxide Accessories

NOS systems are calibrated for optimum performance with a bottle pressure of 900-950 psi. The pressure will change with temperature. Heater kits are thermostatically controlled to keep the bottle near 85° F to provide correct pressure. **Bottle Heater (P/N 14164NOS)** is available for 10 & 15 lb. bottles.

Insulating the bottle helps maintain pressure by keeping heat in the bottle when it's cold, or heat out when it's hot outside. The blankets are made of a rugged, easily cleaned Nylon outer shell with insulation. It's also an excellent "dress up" accessory and perfect for "covering" battle-scarred bottles. **Bottle Blanket (P/N 14165NOS)** is a 7" diameter blanket for the 10 lb. bottle.



P/N 14164NOS



P/N 14165NOS

The primary purpose of a **Purge Valve (P/N 16030NOS)** is to release trapped air or gaseous nitrous from the feed line(s). This helps to ensure consistent performances. And, purging looks cool too!

Nitrous Pressure Gauges (P/N 15910NOS) measure from 0-1500 psi (although recommended level is 900-950 psi) and are essential in monitoring the bottle.

The **Quick Release Hinged Aluminum Bracket (P/N 14140NOS)** is available for 10 lb. and 15 lb. bottles. **P/N 14147NOS** is available for the carbon fiber bottle.



P/N 16030NOS



P/N 15910NOS



P/N 14140NOS

For those who want the ultimate in appearance, NOS offers many popular bottles that are fully polished. **P/N 14745-PNOS** is our 10 lb. fully polished bottle.

For optimum weight reduction and distinctive high-tech looks, these DOT-approved NOS carbon fiber-wrapped bottles are it! Weighs about half of the standard bottle (empty). **P/N 14748NOS** has 12.8 lb. capacity.



P/N 14745-PNOS



P/N 14748-SNOS

NOS Technical Support

Phone: 1-866-464-6553

For online help, please refer to the Tech Service section of our website: www.holley.com

**A5130-SNOS
Date: 4-14-11**