



INSTALLATION INSTRUCTIONS

POINTS ELIMINATOR

CONVERSION PART NO. 2030

IMPORTANT: Before installing the ACCEL Points Eliminator Ignition System, make sure that your vehicle is equipped with an ignition ballast resistor (or loom resistance wire) in the wire between the ignition switch and the coil (+) terminal. One easy way to find the ignition ballast resistor is to check the service manual for your vehicle. You can test your stock ignition system voltage while the engine is at idle at the coil (+) terminal. If the measured voltage is within 1-volt of battery voltage, an ignition ballast resistor must be installed in the wire from the ignition switch. In general, all vehicles equipped with the Prestolite point ignition were equipped with an ignition ballast resistor. If you find your vehicle is not equipped with an ignition ballast resistor, install an ACCEL Ignition Ballast Resistor Part No. 150001 in series in the wire from the ignition switch. Failure to use an ignition ballast resistor will result in the eventual destruction of the ACCEL Points Eliminator Ignition Module.

- Exceptions:** 1) Using one of ACCEL's 4 specially matched coils eliminate the need for a ballast resistor or a resistance wire. These coils are: 140305, 8140 or 8140C SuperStock Canister Coil, 140009 HD E-core SuperCoil.
- 2) If your vehicle is equipped with an ACCEL 275+/300+ Electronic Ignition Control or similar aftermarket ignition control, use the wiring specified for the particular controller, along with its matching coil, such as ACCEL's 140019 SuperCoil.

NOTE: This kit can be installed in the distributor without removing the distributor from the engine if the distributor is easily accessible. However, removal of the distributor from the engine is recommended.

PARTS INCLUDED IN THIS KIT

1 ACCEL Points Eliminator Module	1 Cable Tie
1 Rotor/Shutter Wheel	1 Capsule, Thermal Conductive Grease
1 Distributor Wire Harness	2 Screws, 6-32 x 3/16
1 Female Connector	1 Grommet
1 Mounting Plate	

GENERAL INFORMATION

Ignition Coils:

The ACCEL Points Eliminator Ignition System is designed to work with most stock ignition coils and aftermarket high performance ignition coils. For optimum performance in systems without an ACCEL 275+/300+ or similar ignition control, use one of ACCEL's 4 specially matched coils eliminates the need for a ballast resistor or a resistance wire. These coils are: 140305, 8140 or 8140C SuperStock Canister Coil, 140009 HD E-core SuperCoil.

Spark Plug Wires:

To prevent false triggering and the possibility of premature ignition failures, use suppression type spark plug wire. We recommend spiral core ignition wire, such as ACCEL 8mm Spiral Core SuperStock, ACCEL 8.8mm Spiral Core, ACCEL 300+ RaceWire or ACCEL 8mm Extreme 900 Ignition wire. Do NOT use a copper core spark plug wire set with the ACCEL Points Eliminator kit.

Spark Plug Gaps:

For street applications, use your engine manufacturer's specifications. For racing applications, start with your engine manufacturer's specifications, then experiment with and closely monitor various gaps to achieve maximum performance.

Electric Welding:

Unplug the distributor wire harness before welding on the vehicle.

Optional Circuit Guard Mallory Part No. 29371:

Voltage spikes (voltage transients, power surges) are associated with "noisy" electrical systems from electrical defects such as worn alternator brushes, corroded or oxidized electrical connections and similar electrical problems. Voltage spikes damage the ACCEL Points Eliminator Module. Voltage spikes are clamped and regulated by the optional Circuit Guard from damaging the ACCEL Points Eliminator Module.

INSTALLATION PROCEDURE

Step 1

Disconnect the point trigger wire from the coil (-) terminal.

Step 2

Locate the spark plug wire on the distributor cap that the engine timing is set from. See a service manual for these locations. Mark the distributor housing, in line with this spark plug wire position on the distributor cap.

Step 3

Turn the engine crankshaft until the timing mark lines up with the TDC (top dead center) mark on the timing tab. See a service manual for these locations.

NOTE: Removing the spark plugs may make it easier to turn the crankshaft.

Step 4

Remove and set aside the distributor cap to allow clear access to distributor. Do not remove plug wires from cap. If it is not necessary to remove distributor from engine to install the ACCEL Points Eliminator, remember rotor location so distributor can be reinstalled in engine with the rotor pointing to the same location as when distributor was removed.

NOTE: Review Figure 1 for the parts that will be reused during this conversion.

Step 5

Remove points, condenser, primary lead wire and rotor from distributor.

Step 6

Remove point plate assembly from distributor housing. This can be done without removing vacuum diaphragm.

Step 7

With point plate assembly removed from distributor, disassemble upper point plate from lower stationary base plate by removing spring clip located beneath base plate. Use caution when gently removing the spring clip to avoid spring clip distortion.

Step 8 (See Figure 1)

Reassemble plate assembly using new module adapter plate supplied.

Step 9

Reinstall new plate assembly into distributor housing the same as original point plate.

Be sure vacuum diaphragm arm is properly connected to removable plate.

Step 10

Apply a thin coat of white thermal conductive grease to the bottom of the ACCEL points Eliminator module. Install the ACCEL Points Eliminator module using the two 6-32 screws supplied.

Step 11 (See Figure2)

Push supplied rubber grommet into hole inside distributor housing. Be sure flat on flange of rubber grommet is on the outside of the distributor housing facing upward. Push the three wires from the ACCEL Points Eliminator Module through rubber grommet, to the outside of the distributor housing. Mount connector pins into plastic terminal pin housing supplied. Be sure wires are shoved in to pin housing as shown in Figure 2. Shove pins into pin housing until a definite click is heard.

GREEN WIRE in hole #1
BROWN WIRE in hole #2
RED WIRE in hole #3

Plug the female connector into the distributor wire harness. See figure #2.

Step 12

Install rotor-shutter onto cam sleeve. Make sure that you press on the top of the rotor and not the shutter assembly. Be sure it is seated all the way down onto cam sleeve.

Step 13

If distributor was removed from engine, install back into engine with the rotor pointing to the same location from which it was originally removed.

Step 14

Install the distributor cap onto distributor housing.

WIRING PROCEDURE (See Figures 3, 4 and 5)

Step 1

Make sure that your vehicle is equipped with an ignition ballast resistor (or loom resistance wire) in the wire between the ignition switch and the coil (+) terminal. If you find your vehicle is not equipped with an ignition ballast resistor, install an ACCEL Ignition Ballast Resistor Part No. 150001 in series in the wire from the ignition switch. For optimum performance in systems without an ACCEL 257+/300+ or similar ignition control, use one of ACCEL 4 specially matched coils which eliminates the need for a ballast resistor or a resistance wire. These coils are: 140305, 8140 or 8140C SuperStock Canister Coil, 140009 HD E-core SuperCoil.

Step 2

There are three wires coming from the distributor wire harness:

RED WIRE: Connect to the coil (+) terminal.
GREEN WIRE: Connect to the coil (-) terminal.
BROWN WIRE: Connect to engine block ground.

Clean away any grease, oil and paint from the mounting surface before the connection is made.

NOTE: If an ACCEL 275+/300+ Electronic Ignition Control or any other aftermarket ignition control is being used, connect the distributor wire harness according to the instructions supplied with the ignition control.

DISTRIBUTOR TUNE-UP PARTS	PART NO.
DISTRIBUTOR CAP	120326
ROTOR - SHUTTER WHEEL	334
ACCEL Points Eliminator Module	2005
DISTRIBUTOR WIRE HARNESS	29349

ADDITIONAL CONNECTIONS

Tachometer operation: Connect tachometer wire or wires as recommended by the actual tachometer manufacture.

STARTING THE ENGINE

CAUTION: Be sure all tools, wires and miscellaneous objects are clear of moving engine parts and extreme heat before starting the engine.

Recheck all wires and connections to make sure they are correct. Check and clean, or replace spark plugs. If replacing spark plugs, use types recommended by the engine manufacturer.

Step 1

Connect a timing light. Find the area with the best view of the timing marks.

Step 2

Start engine. If it fails to start, rotate the distributor in small increments clockwise or counterclockwise until engine starts. Do not exceed more than ten degrees of distributor housing rotation in either direction.

Step 3

Set timing as recommended by engine manufacturer, then tighten distributor hold down clamp. Make sure timing is still correct. If timing has moved, repeat this procedure.

Step 4

Re-connect the vacuum hose between the vacuum chamber and the carburetor.

FIGURE 1

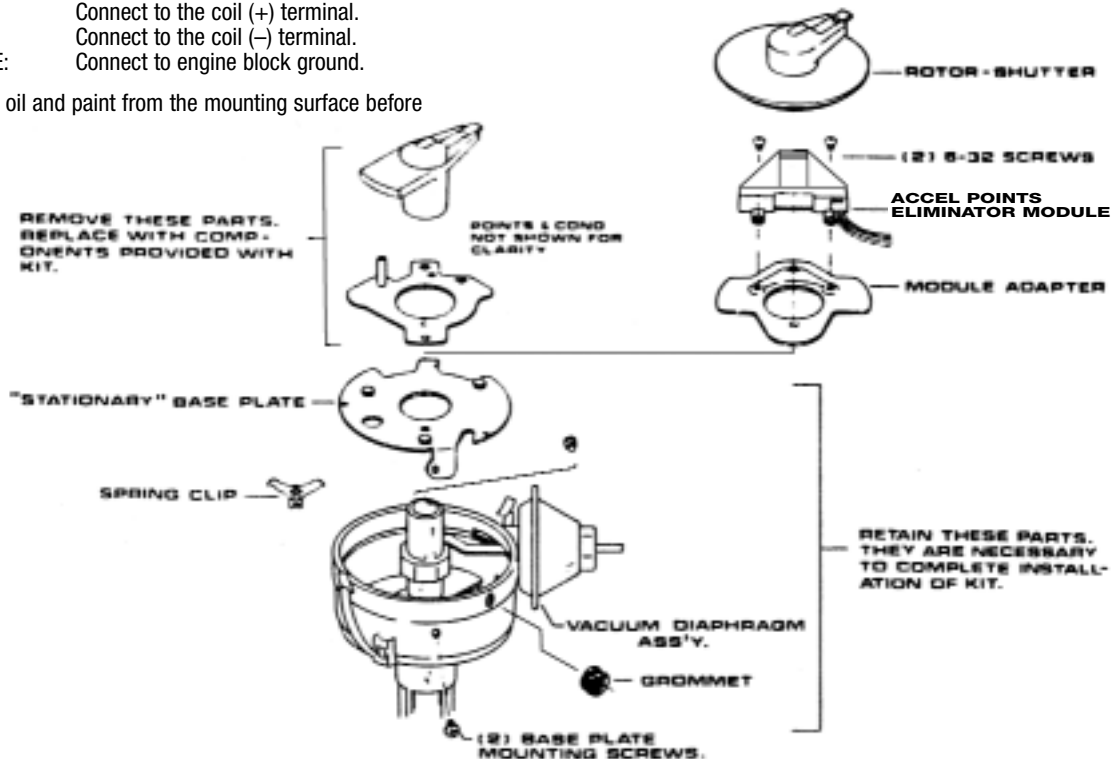

FIGURE 2

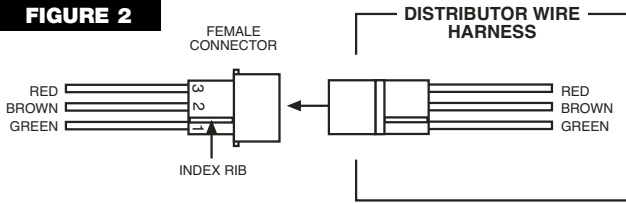

FIGURE 3

ACCEL POINTS ELIMINATOR A 12V IGNITION FEED AND AN ACCEL P/N 140305, 8140 OR 8140C SUPERSTOCK CANISTER COIL.

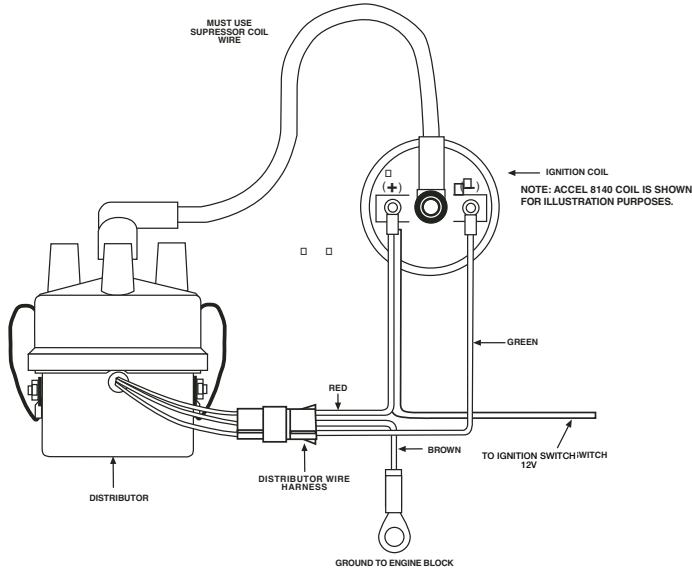

FIGURE 4

ACCEL POINTS ELIMINATOR WIRING DIAGRAM USING OEM PRIMARY RESISTANCE WIRE

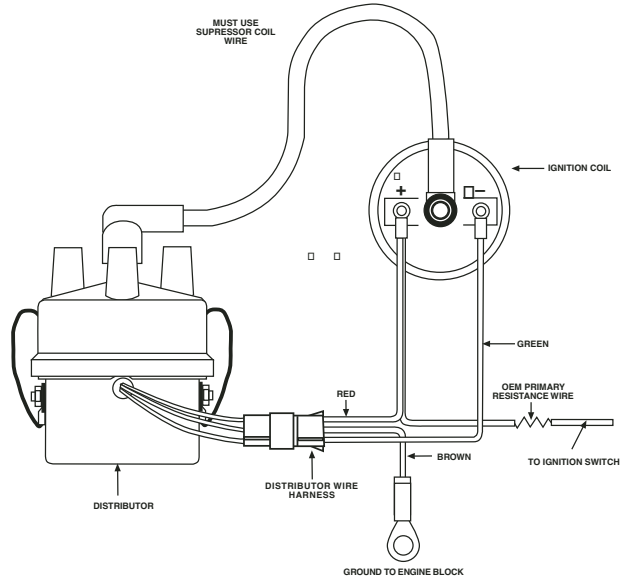

FIGURE 5

ACCEL POINTS ELIMINATOR WIRING DIAGRAM USING A BALLAST RESISTOR

