

INSTALLATION

- 1 DISCONNECT your vehicle's negative (-) battery cable.
- 2 CONNECT the mechanical speedometer drive cable to the back of your mechanical speedometer. Route the cable and connect to your CI DRIVE in desired location.

ATTENTION: When routing, keep cable as straight as possible. Sharp bends or kinks in the speedometer cable can cause too much resistance for the CI DRIVE to function properly.

- 3 MOUNT your CI DRIVE to your vehicle. (Section 7).

ATTENTION: The CI DRIVE is NOT waterproof.

- 4 CONNECT the CI DRIVE wiring. (Sections 1-6).

- 5 RECONNECT your vehicle's negative (-) battery cable.

YOUR CI DRIVE

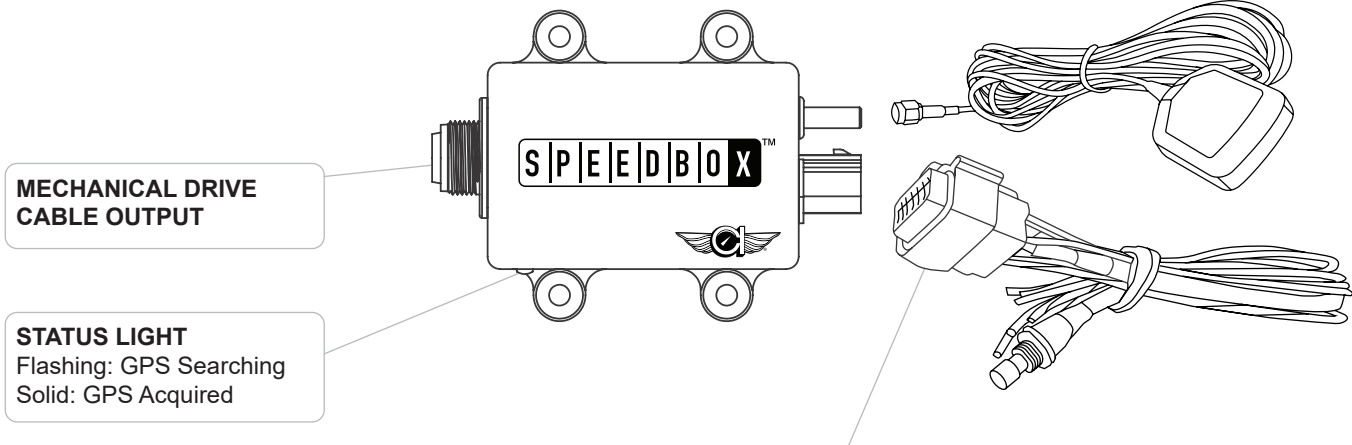

WIRING HARNESS GUIDE

Connectors #3, #4, and #7 are not used.

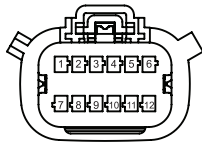

MANDATORY CONNECTIONS

#1: RED: +12v Accessory Power

ATTENTION: SEE SECTION 5.
5 amp In-Line Fuse recommended for +12 Keyed Ignition.

ATTENTION: Power Draw = 0.2 amp.

#2: BLACK: Ground

OPTIONAL CONNECTIONS

Please see Sections 1-6 to determine which connections you will need for your application.

#5: BLACK: Speed Offset Button (-)

#6: BLUE: Cruise Control Output (4000 Pulses per mile)

#8: YELLOW (Green Stripe): VSS Speed Signal

#11: WHITE: Speed Offset Button (+)

CONTACT US

tech@classicinstruments.com
844-342-8437 (Mon.-Fri. 8a-5p EST)
www.classicinstruments.com



INDIVIDUAL VS. COMBO CONNECTION

The CI DRIVE can be used with GPS & VSS. Select one to use individually, or use a combination of GPS/VSS

If using a combination, the GPS signal will override VSS as long as it is active. If the GPS signal drops, the Speedbox™ will switch to the connected backup (VSS) until GPS signal returns.

SECTION 1. GPS CONNECTION

- 1 CONNECT GPS Antenna to the CI DRIVE.
- 2 MOUNT GPS Antenna inside or outside vehicle, with magnetic side facing the ground. Antenna is waterproof and can receive signal through all thin materials except for metal. If mounting inside vehicle, position behind a window to ensure maximum exposure to the sky.
- 3 The CI DRIVE saves your current satellite position, allowing the GPS to restore your position within 10 seconds of power up. If the speedometer has been powered off for longer than 4 hours, signal will take between 30-60 seconds to acquire due to significant satellite movement.

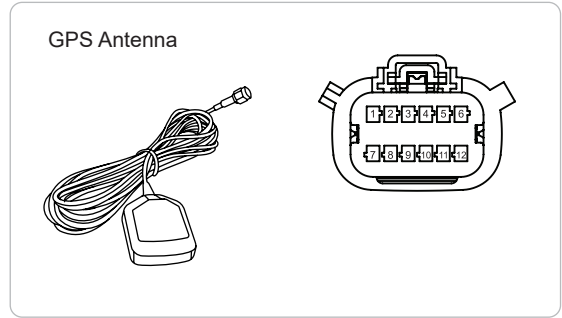

SECTION 2. VSS CONNECTION

1 ATTENTION: The GPS Antenna must be connected to the CI DRIVE for initial VSS calibration. After the vehicle has been driven over 25 MPH, the signals will have the correct pulse rate and the GPS Antenna can be disconnected if GPS/VSS combo is not desired.

CONNECT VSS wire to the speedometer sensor's signal wire.

ATTENTION: Acceptable signals range from 1-100V. 500-250,000 pulses per mile.

For two-wire speedometer sensors: connect either wire to the Speedbox's VSS wire, and connect the other wire to common ground. The two wires can be reversed.

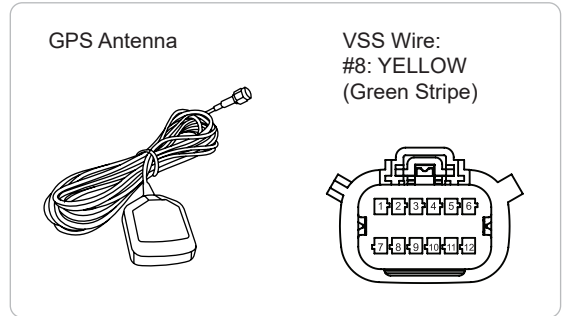



SECTION 3. CRUISE CONTROL CONNECTION (Optional)

Pulsed output for aftermarket cruise control module.

- 1 CONNECT wiring as shown in diagram.

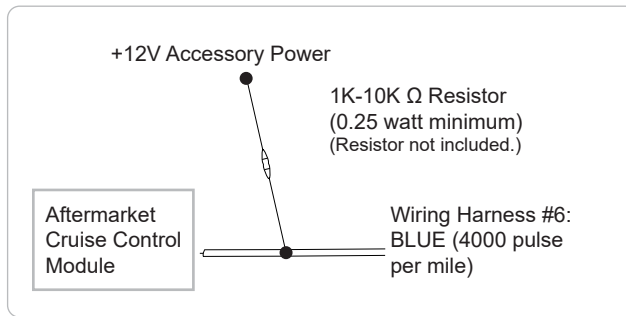

Cruise Control Output Wire:
#6: BLUE

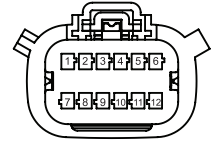

SECTION 4. IN-LINE FUSE

- 1 CHECK that the 3 amp fuse is secure in the fuse holder.
- 2 STRIP the wire ends.
- 3 CONNECT wiring. Use included Butt Splice Connectors for the wiring connections.

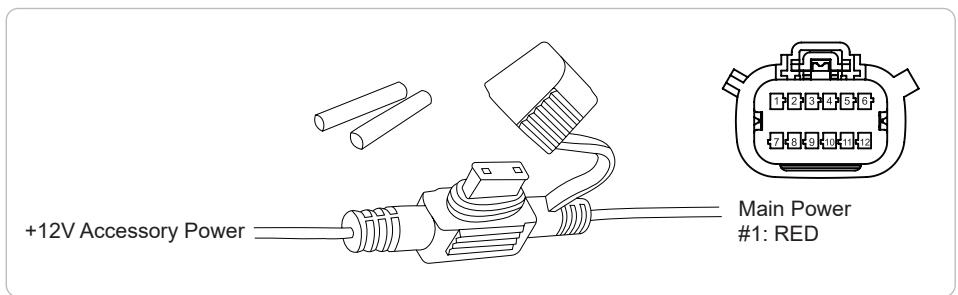

SECTION 5. SPEED OFFSET (Optional)

The CI DRIVE is set to work with most USDM mechanical speedometers. If the speed on your speedometer is consistently off (+/- 10 MPH), you can apply a Speed Offset to improve the accuracy.

CI DRIVE default calibration is 1000 turns/mile. This can be adjusted to anywhere between 100 to 1650 turns/mile.

ATTENTION: If the mechanical speedometer is out of calibration, the odometer will NOT be accurate when a Speed Offset is applied. In these cases, we recommend the speedometer be serviced and calibrated by a qualified technician.

Button:
#5: BLACK

Button (+):
#11: WHITE



Calibrate while the vehicle is parked.

- 1 While the speedometer is connected to the CI DRIVE, power the CI DRIVE on. (The speed signal wire does not need to be connected.)
- 2 PRESS and release the button. The CI DRIVE will move the speedometer needle to what 60 MPH should be.
- 3 HOLD the button to slowly move the pointer clockwise. Release the button and hold it again to move the pointer counter-clockwise.
- 4 POSITION the pointer over 60 MPH, and release the button. The CI DRIVE will store this setting and return to 0 MPH.

The CI DRIVE will now operate using your speedometer's required cable turns-per-mile.



SECTION 6. MOUNTING TEMPLATE

ATTENTION: Your CI DRIVE is water resistant, NOT waterproof. Recommended mounting location is behind the dashboard within the cab.

Use this template to mark holes to drill for the CI DRIVE.

Ensure there is adequate clearance for the unit in the desired mounting location.

Mount using screws or bolts (not included).

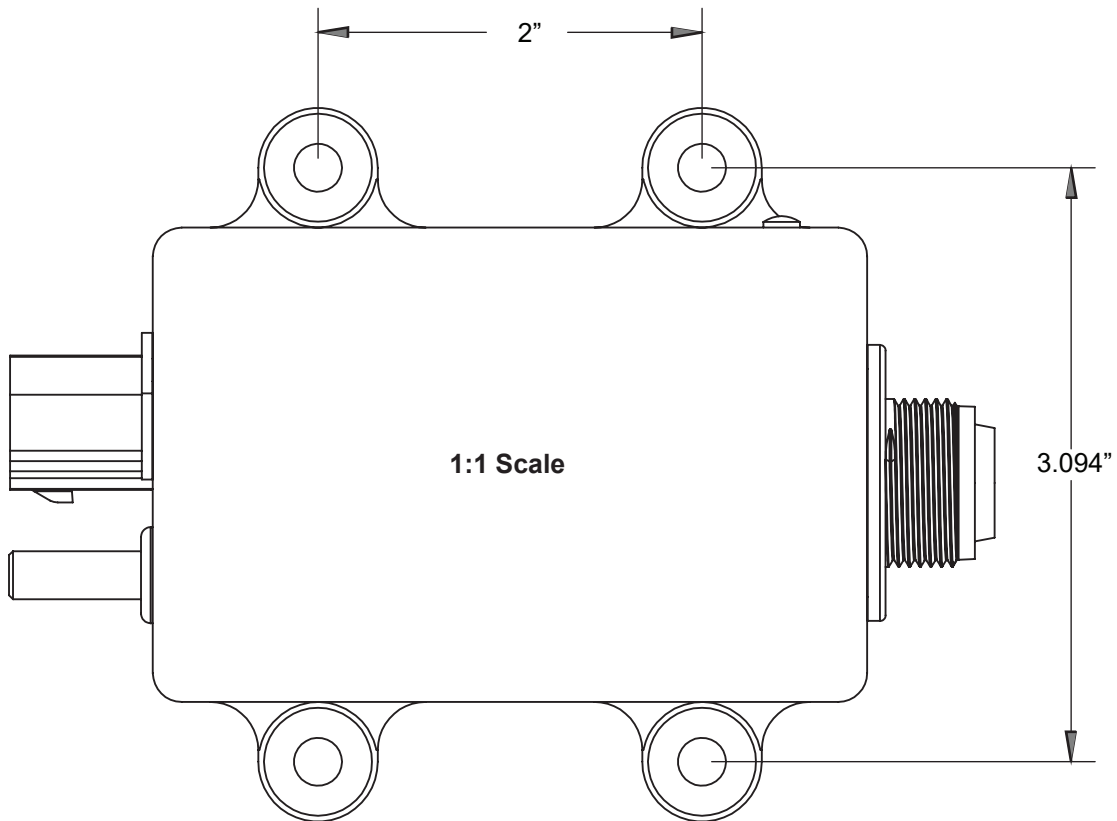

CONTACT US

tech@classicinstruments.com
844-342-8437 (Mon.-Fri. 8a-5p EST)
www.classicinstruments.com