

Detroit Speed
Aluma-Frame Modular Engine Mount Kit
1964.5-70 Mustang
P/N: 060420DS

Thank you for your purchase of the Detroit Speed Adjustable Aluma-Frame Modular Engine Mount Kit. This kit will enable you to easily bolt-in late model Modular Engines into your Aluma-Frame. It will locate the crank centerline, engine mounting angle [3° down in the rear measured from the crank centerline] and bellhousing mounting surface of your Modular Engine in the same position as the stock engine. The engine is offset by 1/4" to the passenger side to create clearance for mounting of the alternator.



Item	Part Description	Quantity
1	Modular Engine Mount Bracket, Left	1
2	Modular Engine Mount Bracket, Right	1
3	M10 x 1.5 x 25mm Flanged Hex Cap Screws	8
4	Adjustable Engine Mount Isolator Assembly	2
5	3/8"-16 x 1-1/2" L Hex Cap Screw	4
6	3/8" SAE Flat Washer	4
7	3/8"-16 Hex Flange Locknut	4
8	Instructions	1

NOTE: The Aluma-Frame will need to be modified to clear the alternator on the Coyote engine application. Detroit Speed offers an alternator relocation bracket, P/N: 060436DS that will be required along with modifying the Aluma-Frame to fit the Coyote engine.

Install the left and right hand engine mount brackets to the block with the provided M10 flange bolts as shown in Figures 1 and 2 using a medium strength thread locker (Loctite 242 or equivalent) on the threads. Some blocks will have only three mounting holes or the lower rear bolt hole the right side will line up with the other hole in the bracket. Torque the bolts to 30 ft-lbs.

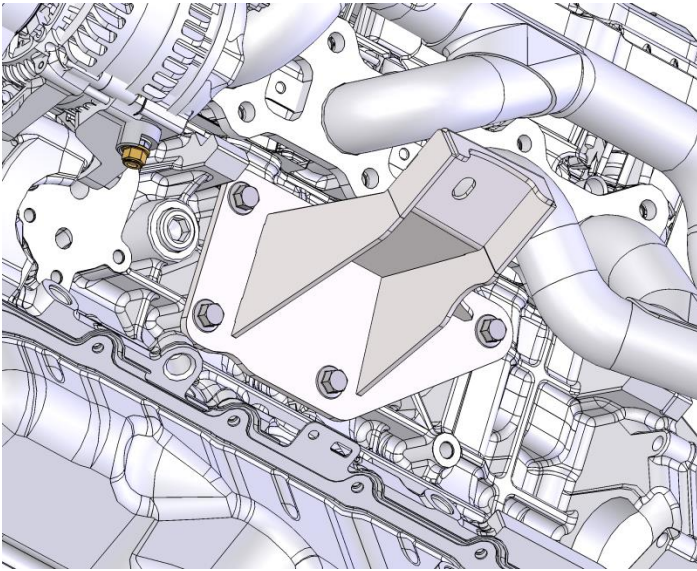

Figure 1 - Left-Hand Bracket Installation

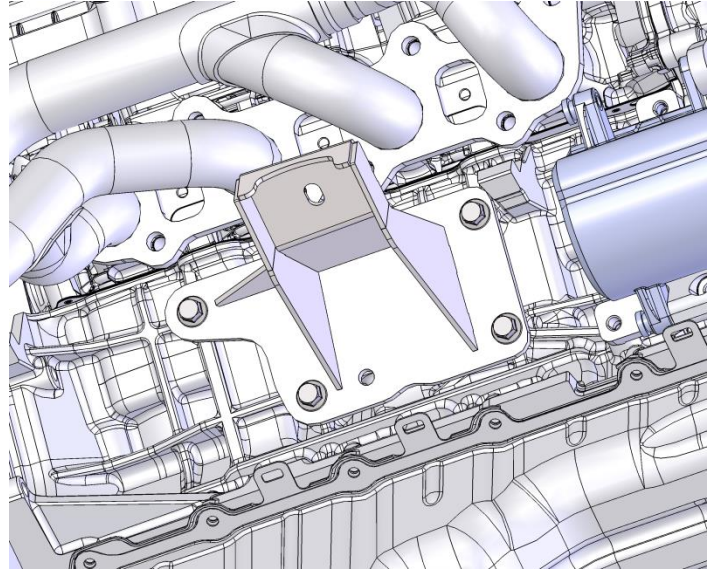

Figure 2 - Right-Hand Bracket Installation

The Aluma-Frame adjustable engine mount isolators are designed to minimize the transmission and drivetrain vibrations while providing secure mounting for your engine. They are adjustable in 1/4" increments from 1/4" higher than standard height to 1" lower.

Install the Engine Mount Isolators on the Aluma-Frame with the provided 3/8" bolts, washers, and locknuts as shown in Figure 3 and torque to 30 ft-lbs. Once the engine is installed, torque the M10 locknuts on the isolator assemblies to 30 ft-lbs.

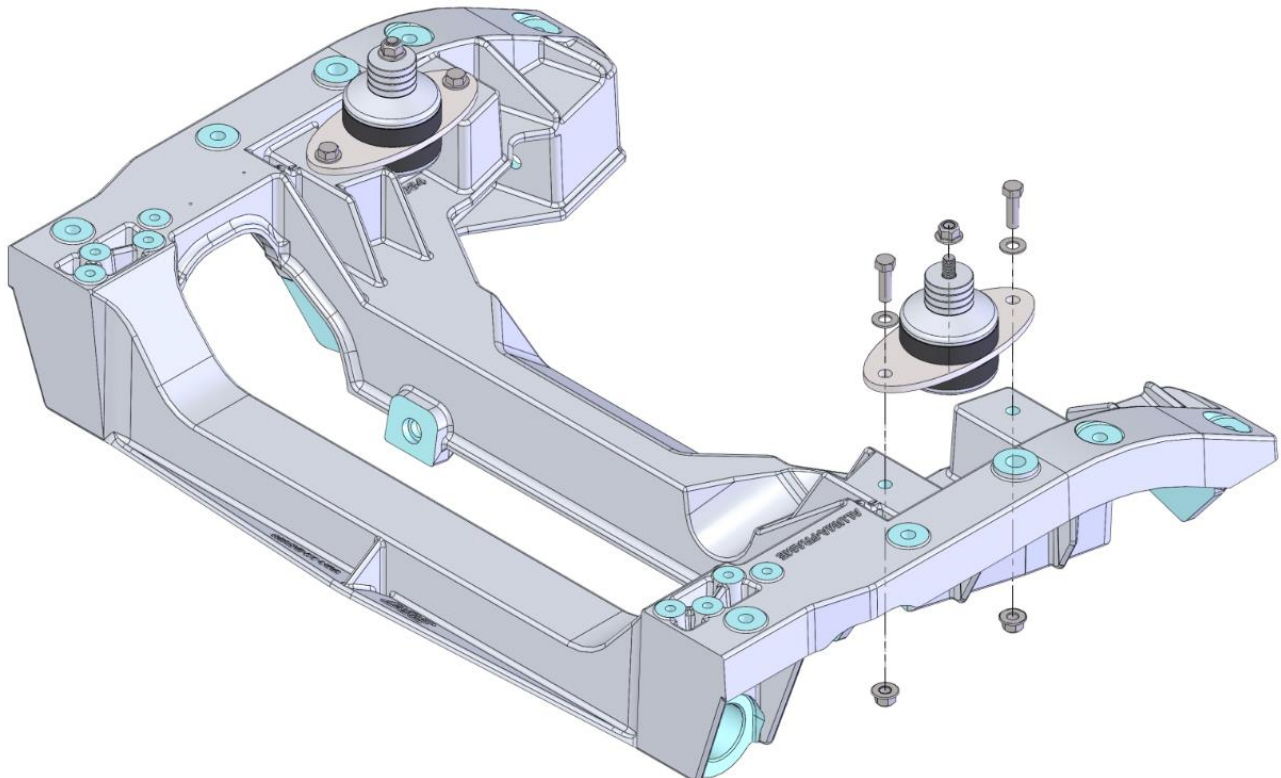

Figure 3

Engine Mount Adjustment

If the mounts are going to be used in conjunction with a Detroit Speed engine mount kit it is recommended that the isolators remain at the standard height (Figure 4). All DSE engine mount kits are designed for the engine mount isolators to be installed at the standard height. For some custom installations, the engine mount height can be adjusted if needed.

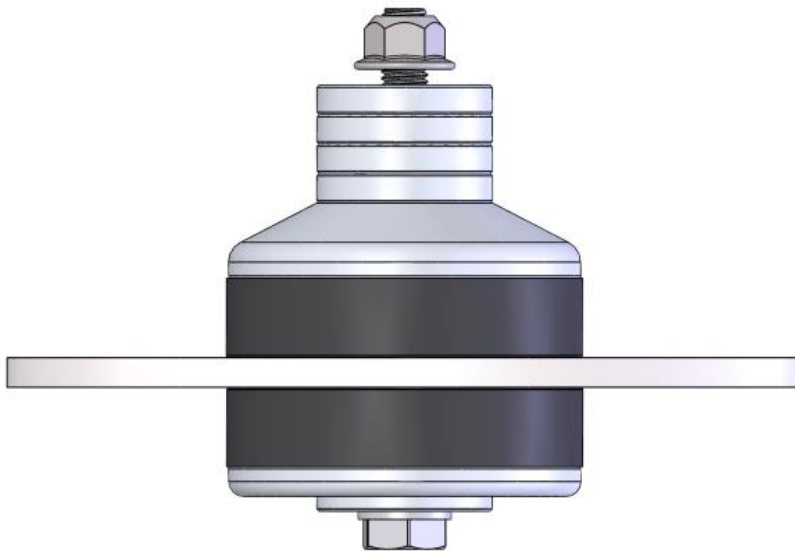

Figure 4 - Standard Height-Four spacers on the top and one spacer on the bottom.

To Lower the Engine: In order to lower the engine height, remove the desired number of spacers from the engine mount isolator assemblies (Figure 5). Each spacer is 1/4" tall, so the engine can be lowered up to 1" in 1/4" increments.

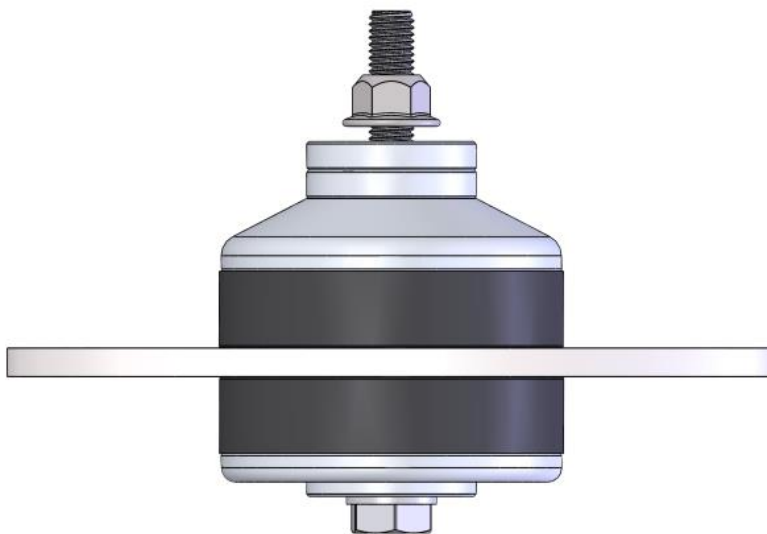

Figure 5 - Two top spacers removed-1/2" lower.

To Raise the Engine: In order to raise the engine, the 1/4" spacer at the bottom of the mount needs to be moved to the top resulting in a 1/4" increase in height (Figure 6 on the next page). Disassemble the mount by holding the top cap with a spanner wrench or other suitable tool and loosen the M10 bolt on the bottom of the mount. Remove the 1/4" spacer from the bolt and then reassemble the mount. Torque the bolt to 30 ft-lbs. Add the spacer that was removed from the bottom of the mount to the stack of spacers on the top of the mount.

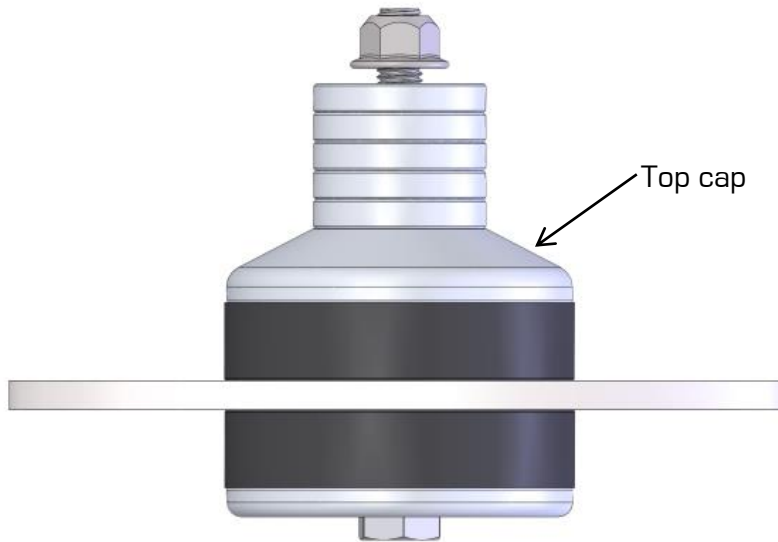

Figure 6: Bottom spacer moved to top-1/4" higher.

If you have any questions before or during the installation of this product, please contact Detroit Speed at tech@detroitsspeed.com or 704.662.3272