

**Detroit Speed**  
**Rear Coilover Conversion Kit**  
**1982-2002 Camaro/Firebird**  
P/N: 042440DS, 042440-SDS, 042440-DDS, 042440-RDS,  
042441DS, 042441-SDS, 042441-DDS, & 042441-RDS

The Detroit Speed Rear Coilover Conversion Kit allows the latest in coilover spring/shock technology to be bolted on, bringing your vehicles handling and ride into the 21<sup>st</sup> century. The kit replaces the existing coil spring and shock combination with a "Detroit Tuned" coilover shock and spring package. The coilover kit offers extensive ride height adjustability and requires only minor drilling on the existing axle bracket. All necessary hardware is included in the kit to complete the conversion.



Scan the QR code to guide you through the step-by-step installation video of the 1982-02 Camaro/Firebird DSE Rear Coilover Conversion Kit installation.

Item	Part Description	Quantity
1	Detroit Speed "Detroit Tuned" Coilover Shocks	2
2a	Coilover Spring (275lb/in) (1982-1992)	2
2b	Coilover Spring (175lb/in) (1993-2002)	2
3	Upper Rear Coilover Mount Assembly LH	1
4	Upper Rear Coilover Mount Assembly RH	1
5	Lower Rear Coilover Mount Assembly LH	1
6	Lower Rear Coilover Mount Assembly RH	1
7	Coilover Hardware Kit	1
8	Detroit Speed/JRi Spanner Tool	1
9	Instructions	1

Hardware Checklist - Detroit Speed Rear Coilover Conversion Kit			
Item	Description	Quantity	Check
1	1/2"-20 x 2-1/2" L Hex Head Bolt	2	
2	1/2"-20 x 2-1/4" L Hex Head Bolt	2	
3	1/2"-20 x 1-1/4" L Socket Head Bolt	2	
4	1/2"-20 Nylock Nut	6	
5	1/2"-20 Nylock Jam Nut	2	
6	1/2" SAE Flat Washer	6	
7	1/2" SAE Extra Thick Flat Washer	2	
8	1/2" AN Washer	2	
9	3/8"-24 x 3" L Hex Head Bolt	2	
10	3/8"-24 Nylock Nut	2	
11	3/8" SAE Flat Washer	4	
12	3/4" OD x 1/2" ID x 1/2" L Steel Bushing	4	

Fastener Torque Specifications	
Application	Torque (ft-lbs)
Upper Coilover Bracket Mounting Nuts	50
Upper Shock Mounting Bolts	60
1/2" Lower Coilover Bracket Mounting Bolts	65
3/8" Lower Coilover Bracket Mounting Bolts	30
Lower Shock Mounting Bolts	50

#### Installation:

1. To begin installation, chock the front wheels and loosen the rear lug nuts. Raise and support the rear of the vehicle with jack stands under the frame. Remove the rear wheels.
2. Remove the rear sway bar. Remove the bolts from the lower trailing arms at the rear axle so they can drop down away from the rear axle.
3. Support the rear axle and remove the factory shocks and springs from the vehicle.  
**CAUTION:** The springs may be under pressure and may require the use of a spring compressor.

4. Before installing the coilover mounts, identify which are for the left and right hand side of the vehicle (Figure 1 and 2).



Figure 1 - LH Coilover Mounts      Figure 2 - RH Coilover Mounts

5. Position the correct lower coilover mount on the axle bracket that was used for the factory lower shock mount. **NOTE:** You may need to use a rubber mallet to tap the bracket so it seats tightly against the axle bracket. Use the 1/2"-20 x 1-1/4" L Socket Head Bolt and hardware to hold the bracket in place. Do not tighten at this point. It will be necessary to drill a hole through the side of this bracket to install the lower coilover mount. Using the coilover mount as a template scribe a hole on the axle bracket (Figure 3).



Figure 3 - Lower Coilover Mount

6. Remove the lower coilover mount and mark the center point of the scribed hole. Drill a 3/8" hole through the factory axle bracket (Figure 4).



Figure 4 - Drill Factory Axle Bracket

7. Use the provided 3/8"-24 x 3" L hex head bolt, Nylock nut and washers to install the lower coilover mount (Figure 5). **NOTE:** The 3/8" bolt should have a 3/8" washer on the bolt head side and on the Nylock nut side of the bolt.



Figure 5 - Lower Coilover Mount

8. Install the provided 1/2"-20 x 1-1/4" L socket head bolt and 1/2" AN washer through the slotted hole in the lower coilover bracket (Figure 6) and through the axle bracket. Install the 1/2"-20 Nylock nut and washer onto the bolt on the back side of the axle bracket and tighten.



Figure 6 – Lower Coilover Bracket

9. Torque the 3/8" hardware to 30 ft-lbs. and the 1/2" hardware to 65 ft-lbs.
10. Repeat steps 4 through 9 for the opposite side of the vehicle.
11. Assemble the coilover shock and spring at this time.

Remove the upper spring seat from the retaining ring using a rubber hammer and moving it down off the upper shock mount (Figure 7). Remove the retaining ring from the upper shock mount and pass the upper spring seat over the upper shock mount (Figure 8). Slide the coilover spring over the top of the upper shock mount. Install the upper spring seat back over the top of the upper shock mount and re-install the retaining ring back onto the upper shock mount. Press the upper spring seat up onto the retaining ring so it locks in place.



Figure 7 – Remove Upper Spring Seat



Figure 8 – Spring Seat & Retaining Ring

12. Once the coilover shock and spring is assembled, install the upper coilover mount on the coilover shock. Use the provided 1/2"-20 x 2-1/2" L hex head bolt and the 3/4" x 1/2" L steel bushing. Make sure the bolt head is facing in the correct direction and slide it through the upper coilover mount and through the body side upper shock eyelet. (Figure 9 on the next page). **NOTE:** The shock monoball should be in between the welded tube on the bracketry and the floating spacer.



Figure 9 - Pre-assemble Shock

13. Using anti-seize on the threads of the bolt, install the 1/2"-20 Nylock nut and washer onto the 1/2"-20 upper shock bolt. We do recommend that you torque the upper shock bolt at this time to 60 ft.-lbs. as you may not be able to access it once it is installed in the vehicle. **NOTE:** If you are using the remote canister double adjustable coilover shocks, make sure the hose is facing the flat side of the upper coilover mount so the hose will point towards the rear of the vehicle.
14. Repeat steps 12 and 13 for the other coilover shock.
15. Determine the LH and RH upper coilover mount (Figure 1 and 2) and install the correct assembly into the vehicle. Install the coilover shock and mount assembly into the vehicle through the factory shock location (Figure 10). The upper coilover mount should fit the contour of the vehicle in front of the factory coil spring perch. From the inside of the vehicle, thread the 1/2"-20 Nylock nut and 1/2" extra thick flat washer onto the upper coilover mount and torque the nut to 50 ft.-lbs. Repeat this step for the opposite side of the vehicle.



Figure 10 - Remote Canister Shock Shown

16. With all of the coilover shock mounts installed and the coilover shocks mounted at the upper coilover mount, jack up the rear axle of the vehicle to line up the coilover shocks with the holes in the lower coilover mount. **CAUTION:** Make sure the coilover shocks are out of the way when jacking up the rear axle.

17. Attach the lower shock eyelet to the lower coilover mount using the provided 1/2"-20 x 2-1/4" L Hex Head Bolt with the 3/4" x 1/2" L bushing. Use a floor jack to position the rear-end height so the bolts line up. The bolt should go in from the inboard side of the lower coilover mount and use the 1/2" Nylock jam nut and washer using anti-seize on the threads of the bolt. The shock monoball should be in between the welded tube on the bracketry and the floating spacer. (Figure 11). Repeat for the opposite side of the vehicle. **NOTE:** If you are using the double adjustable shocks, keep the adjustment window facing forward of the axle for adjustment.



Figure 11 - Lower Shock

18. Torque the lower 1/2"-20 shock bolts to 50 ft.-lbs.
19. Thread the coilover adjusting nut down until there is some tension on the spring. Once tension is reached, turn the nut an additional three to four turns. Ride height will be adjusted later as this is simply a starting point. DSE recommends cleaning the threads of the shock. Once the threads are clean, DSE recommends applying dry bicycle chain lube to the threads of the shock body before adjusting the spanner nut and compressing the coilover spring. Allow the chain lube to dry before adjusting the spanner nut.
20. Re-install the trailing arms back into the rear axle brackets and torque to 75 ft.-lbs. Re-install the rear sway bar back into the vehicle.
21. Re-install the rear wheels and torque to the manufacturer's recommended torque specs. Lower the vehicle to the ground.
22. Once the vehicle is set on the ground, settle the suspension by jouncing both the front and rear by hand by pressing down on the body. Check the ride height at this point and adjust as necessary by turning the coilover adjusting nut. Detroit Speed does include a Spanner Tool (P/N: 031060DS) to adjust ride height however if you have the adjustable coilover shocks, DSE does offer an Adjustment Tool available as P/N 031061DS if needed (Figure 12).



Figure 12 - Detroit Speed Spanner & Adjustment Tools

23. Once the ride height has been adjusted properly, lock the spanner nut in place. If you have the non-adjustable coilover shocks, tighten the set screw in the spanner nut to the shock body. If you have the adjustable coilover shocks, tighten the lock ring to the spanner nut so they lock together in place.

24. The installation is now complete. If the upgrade was purchased for the Single Adjustable, Double Adjustable Shocks or the Double Adjustable Shocks w/Remote Canisters, refer to the appropriate sections below for adjustability.

***Detroit Speed Single Adjustable Shock Applications***

To change from the recommended “Detroit Tuned” valving, adjustments can be made independently to the rebound setting. The rebound is controlled by the knob at the upper shock mount (Shock is mounted body side down). The knob rotates clockwise (+) to increase the damping and counterclockwise (-) to decrease the damping (Figure 13a on the next page).



**Figure 13a- Detroit Speed Single Adjustable Shocks**

To return to the Detroit Speed recommended settings, turn the knob clockwise (+) to full damping. Once at full damping, turn counterclockwise (-) to reach the recommended settings. Refer to Figure 13b for the rebound settings.

Rebound (Shaft Knob)..... 15 Open (counterclockwise, -)

**Figure 13b - Detroit Speed Recommended Settings**

**Adjuster Operation**

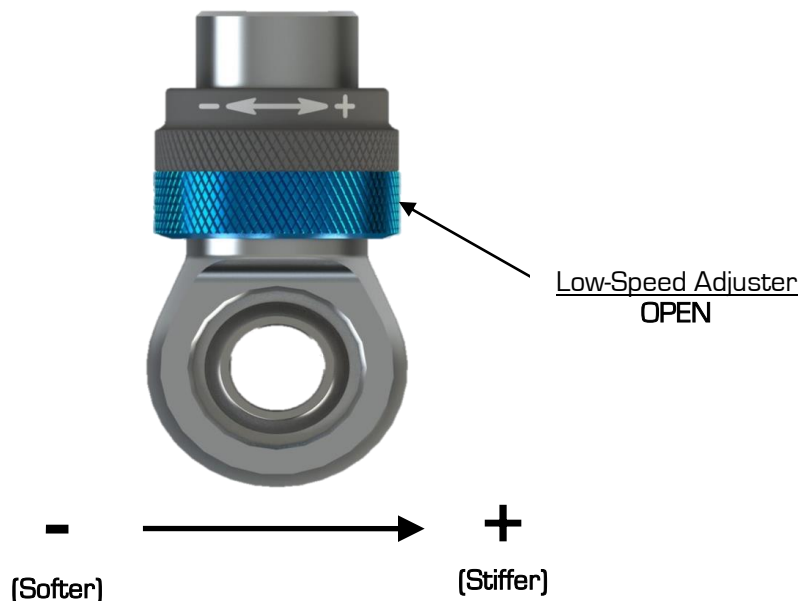



- **Adjuster (60-64 Clicks)**

The low-speed adjuster is a “clicker” style adjuster meaning that its adjustment is measured by detents located inside the blue adjuster knob. There are 16 clicks per 1 revolution of the knob. It uses a right-hand thread in its operation which means as you increase low-speed, the adjuster will move up on the eyelet. The recommended change for an adjustment is 8 clicks at a time. The low-speed adjuster’s reference position is **full stiff** (closed, or all the way up) and referred to -0 (-0 = full stiff, -64 = full soft).

- **Tuning Notes**

- **Racetrack**

- For more grip, soften the damping.
- For increased platform control, stiffen the damping.

- **Street**

- For a more comfortable ride, soften the damping

**\*DO NOT FORCE KNOB WHEN IT STOPS TURNING, YOU MAY DAMAGE THE ADJUSTER AND INTERNAL HARDWARE**

*Detroit Speed Double Adjustable Shock Applications*

To change from the recommended “Detroit Tuned” valving, adjustments can be made independently to both the high and low speed settings. The rebound is controlled by the sweepers at the upper shock mount. The sweepers rotate clockwise (+) to increase the damping and counterclockwise (-) to decrease the damping. The sweepers can be seen in Figure 14a.



**Figure 14a - Detroit Speed Double Adjustable Shocks**

When adjusting the low speed rebound start at full (+) position, when adjusting the high speed rebound start at full (-) position. To return to the Detroit Speed recommended settings turn the sweeper clockwise (+) to full damping for the low speed setting, and counterclockwise (-) to full damping for the high speed setting. Once at full damping, turn counterclockwise (-) for the low speed setting, and clockwise (+) for the high speed setting to reach the recommended settings. Refer to Figure 14b for recommended settings.

Low Speed Rebound [Sweeper]..... 15 sweeps [counterclockwise](-)  
 High Speed Rebound [Sweeper]..... 4 sweeps[clockwise](+)

**Figure 14b - Detroit Speed Recommended Settings**

## Detroit Speed Double Adjustable Shocks w/Remote Canisters

To change from the recommended "Detroit Tuned" valving, adjustments can be made independently to both the high and low speed settings. The rebound is controlled by the sweepers at the upper shock mount. The sweepers rotate clockwise (+) to increase the damping and counterclockwise (-) to decrease the damping. Refer to Figure 15a.

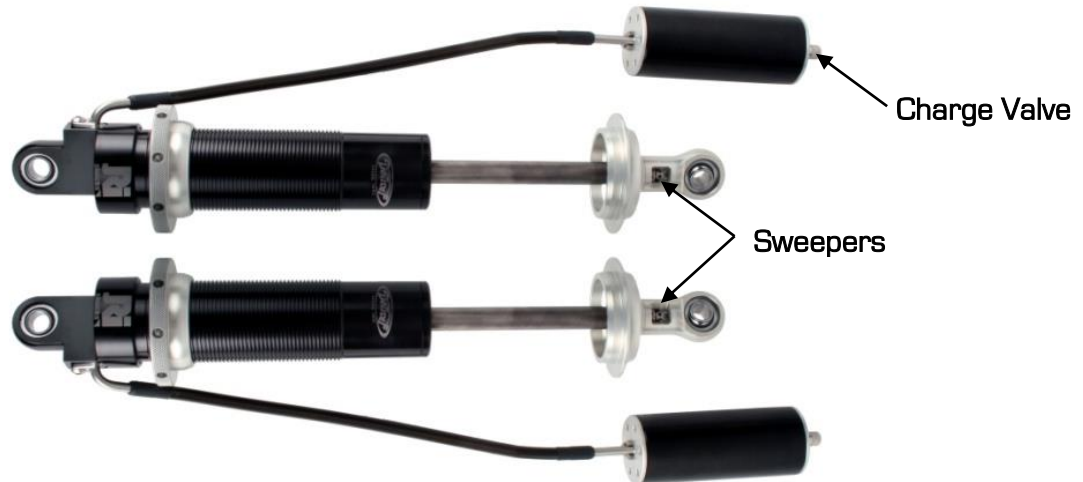

Figure 15a - Detroit Speed Double Adjustable Shocks w/Remote Canister

When adjusting the low speed rebound start at full (+) position, when adjusting the high speed rebound start at full (-) position. To return to the Detroit Speed recommended settings turn the sweeper clockwise (+) to full damping for the low speed setting, and counterclockwise (-) to full damping for the high speed setting. Once at full damping, turn counterclockwise (-) for the low speed setting, and clockwise (+) for the high speed setting to reach the recommended settings. Refer to Figure 15b for recommended settings.

Low Speed Rebound (Sweeper)..... 15 sweeps [counterclockwise](-)  
High Speed Rebound (Sweeper)..... 4 sweeps [clockwise](+)

Figure 15b - Detroit Speed Recommended Settings

### Adjuster Operation

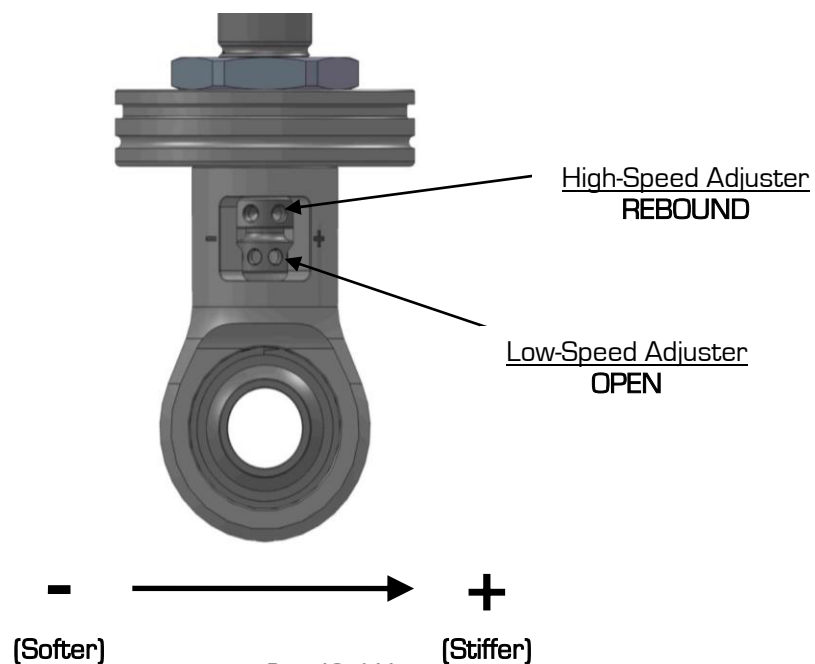

- **High-Speed Adjuster (12 Sweeps)**

The high-speed adjuster is a “sweep” style adjuster meaning that its adjustment is measured by the location of the adjuster in the eyelet window. It uses a left-hand thread in its operation which means; as you increase high-speed, the adjuster will move down in the window\*. The high-speed adjuster’s reference position is **full soft** and referred to as +0 (+0 = full soft, +12 = full stiff).

- **Low-Speed Adjuster (25 Clicks)**

The low-speed adjuster is a “clicker” style adjuster meaning that its adjustment is measured by detent grooves located inside the high-speed shaft. It uses a right-hand thread in its operation which means; as you increase low-speed, the adjuster will move up in the window. The low-speed adjuster’s reference position is **full stiff** and referred to as -0 (-0 = full stiff, -25 = full soft).

*\*The low-speed adjustment does not change when adjusting the high-speed.*

To aid in the installation of the reservoirs, we also offer a set of Billet Aluminum Remote Canister Mounts. The canister mounts are available exclusively through Detroit Speed, P/N: 032102DS (Figure 16).



Figure 16 – Billet Aluminum Remote Canister Mounts

If you have any questions before or during the installation of this product, please contact Detroit Speed at [tech@detroitsspeed.com](mailto:tech@detroitsspeed.com) or 704.662.3272