

Detroit Speed
Leaf Spring Front Delrin Bushing Kit
 1967-81 Camaro/Firebird, 1968-74 Nova
 P/N: 041224DS

Our Delrin™ Front Leaf Spring Bushing Kits provide the ultimate handling performance for leaf spring applications by reducing bushing compliance. The bushings also offset the leaf springs inboard to gain more wheel and tire clearance over stock bushings. You can also purchase the entire bushing and shackle kit, the rear bushings, or the front bushings.



Item	Component	Quantity
1	Leaf Spring Crush Tube	2
2	Delrin Leaf Spring Sleeve Bushing	2
3	Delrin Leaf Spring Thrust Bushing	4
4	Leaf Spring Aluminum Front Bushing	2
5	Flush Zerk Fitting Nozzle	1

Notes:

Install the grease fittings facing down to insure easy access for greasing. Position the thick side of the bushing on the outboard side of the leaf spring to provide maximum tire to spring clearance. Grease bushings before use.

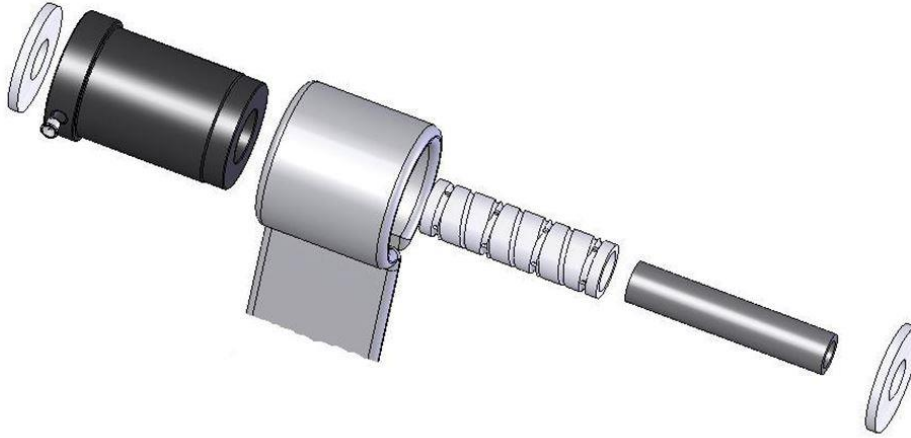

Figure 1: Passenger Side Spring, Viewed from the Bottom

If you have any questions before or during the installation of this product, please contact Detroit Speed at tech@detroitsspeed.com or 704.662.3272

***Legal Disclaimer:** Detroit Speed is not liable for personal, property, legal, or financial damages from the use or misuse of any product we sell. The purchaser is solely responsible for the safety and performance of these products. No warranty is expressed or implied.*