

# **MSD** INSTALLATION INSTRUCTIONS

## **MSD Wide-Band O2 Sensor PN 7765**

**ONLINE PRODUCT REGISTRATION:** Register your MSD product online. Registering your product will help if there is ever a warranty issue with your product and helps the MSD R&D team create new products that you ask for! Go to [www.msperformance.com/registration](http://www.msperformance.com/registration).

### **Parts Included:**

- 1 - MSD Wide Band Oxygen Sensor Module PN7765
- 1 - Oxygen Sensor
- 1 - Parts bag

### **Parts Required:**

- Power Grid System ie. PN 7730
- Power Grid Hub PN 7740

### **FEATURES**

- Plug & Play. No settings or calibrations necessary
- High Speed Recording
- Works seamlessly with other wide-band modules

### **OPERATION**

The Wide-Band O2 sensor is a single channel air-fuel ratio (AFR) module designed to interface with the Power Grid (PN7730) to monitor and record the AFR of internal combustion engines. The Wide-Band O2 sensor module is capable of measuring AFR starting at  $\lambda = 0.65$  (9.5:1 Gasoline AFR equivalent). The AFR range is configurable when the module is connected to the MSDView software through the Power Grid.

The Wide-Band Oxygen sensor module also provides an analog output proportional to the AFR. This analog output can be sent to a gauge or a data acquisition system. The dual-color LED provides the status of the sensor at a glance.

*Multiple Wide-Band O2 modules and sensors can be connected in the same Power-Grid setup. For example, one sensor with a module can be placed on the right side of the engine, while a second can be placed on the left side of the engine.*

### **MOUNTING AND WIRING**

The WBO2 Sensor module must be mounted in a sturdy, dry location and not exposed to extreme heat. The unit should not be immersed or subjected to direct spray from a power washer.

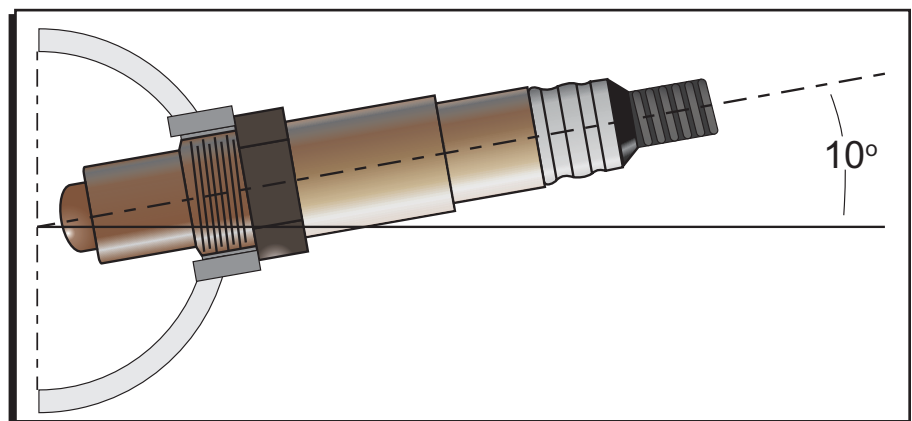

**Figure 1 Mounting recommendation.**

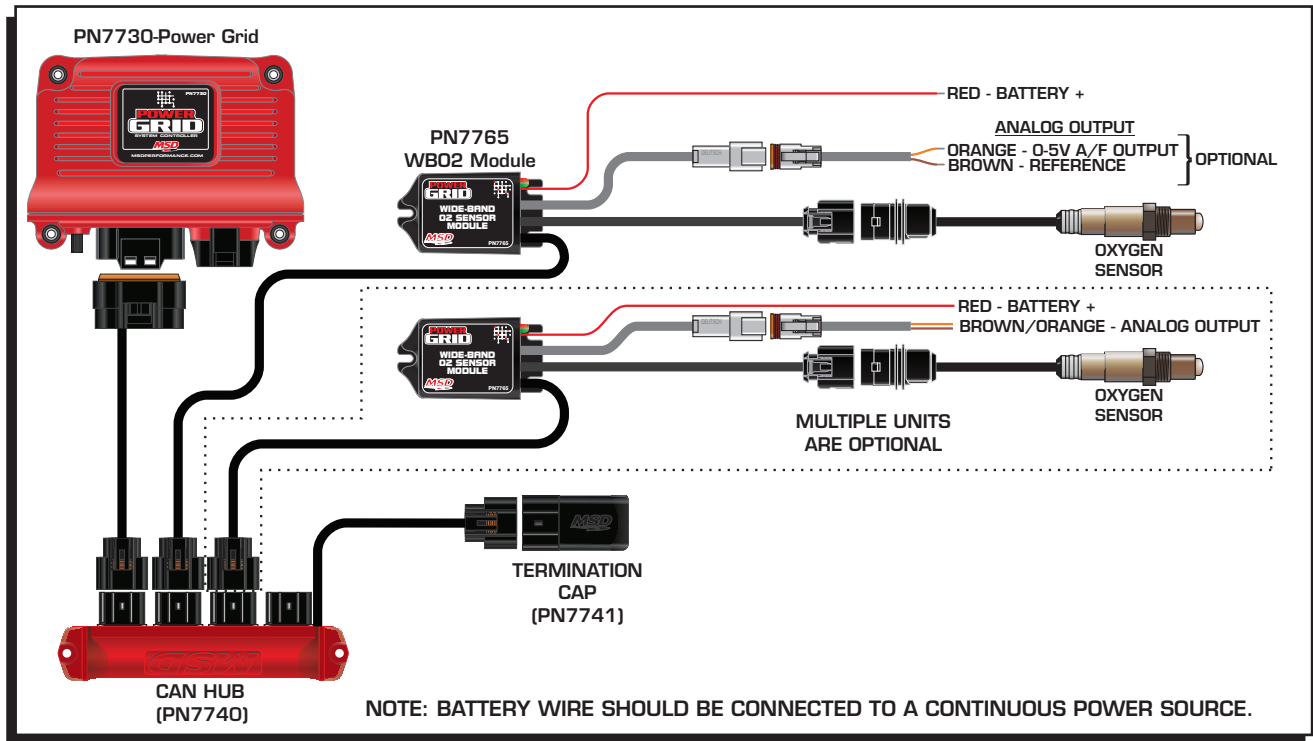

Figure 2 Wiring of the WB02 Sensor Module(s)

WIRING CHART				
FUNCTION	PIN	WIRE COLOR	WIRE DESCRIPTION	NOTES
CAN	1	BLACK	CAN Lo	DATA ACQUISITION CONNECTS TO POWER GRID CAN BUS
	2	GRAY(YEL SLV)	CAN SHIELD	
	3	BLACK	GROUND	
	4	RED	CAN Hi	
	5	RED	IGNITION 12V	
	6	NOT USED	NOT USED	
O2	1	RED	PUMP CURRENT APE / IP	CONNECT TO OXYGEN SENSOR
	2	YELLOW	VIRTUAL GROUND IPN/VM	
	3	BLACK/WHITE	HEATER VOLTAGE H- / Uh-	
	4	BLACK/RED	HEATER VOLTAGE H+ / Uh+	
	5	GREEN	TRIM RESISTOR RT/ IA	
	6	BLACK	NERNST VOLTAGE UN / RE	
ANALOG	1	ORANGE	0-5 VOLT A/F OUTPUT	OUTPUT VOLTAGE CAN BE CALIBRATED VIA MSD VIEW. THE DEFAULT OUTPUT VOLTAGE, 0-5V, CORRESPONDS TO AN AFR (AIR FUEL RATIO) 9-18 OF GASOLINE. A ZERO (0) VOLT READING IS AN AFR OF 9 AND 5V IS AN AFR OF 18. (2 AFR PER VOLTS) OUTPUT TO A GAUGE OR DAQ IS AN OPTION.
	2	BROWN	REFERENCE	
LOOSE WIRE	-	RED	BATTERY+	POWER SOURCE

**PROGRAMMABLE FEATURES AND SETTINGS**

**SETTINGS**

Under the SETTINGS tab the user can scale the air-fuel ratio range of the analog voltage output, and select the fuel calibration value used to convert lambda to air-fuel ratio.

**O2 AFR Low Limit:** This setting controls the low limit of the air-fuel ratio. 0 volts output voltage would be equal to this AFR setting.

**O2 AFR high limit:** This setting controls the high limit of the air-fuel ratio. 5 volts output voltage would be equals to this AFR setting.

**Fuel Calibration:** This setting controls the calibration value used in the lambda-to-AFR conversion. The fuel calibration options are:

FUEL CALIBRATION OPTIONS	
Gasoline	14.7
Methanol	6.4
Ethanol	9
E85	9.8
Propane	15.5
Diesel	14.6
CUSTOM	User configurable

**Custom Fuel Calibration:** Custom fuel calibration value entered by the user is only available when the user selects CUSTOM in the Fuel Calibration setting.

**DATA ACQUISITION**

The data acquisition in this module works in conjunction with the Power Grid data recorder. It can record the air-fuel ratio and heater voltage. When connected to the Power Grid, the Wide-Band O2 sensor sends the enabled data acquisition channels over the CAN bus to be recorded by the Power Grid. These channels will be recorded at a rate of up to 10 samples per second.

**CHANNELS**

CHANNEL	DESCRIPTION
Air Fuel Ratio	Air-Fuel ratio measurement
Heater Voltage	Voltage applied to the heater integrated in the LSU 4.9 sensor

**MONITORS**

MONITOR	DESCRIPTION
Engine Speed	Engine Speed (RPM) received from the PN7730
Air Fuel Ratio	Air-Fuel ratio measurement
Battery Voltage	Voltage applied to the battery wire
Heater Voltage	Voltage applied to the heater integrated in the LSU 4.9 sensor

# **INSTALLATION INSTRUCTIONS**

## **STATUS LED**

<b>LED</b>	<b>DESCRIPTION</b>
Orange	Warm up in progress
Red	Fault
Green	Normal operation
Blinking (any color)	Communicating with MSD View

## **ALERTS**

<b>ALERT</b>	<b>DESCRIPTION</b>
Heater Open	Heater open circuit
Heater Shorted to Ground	Heater short circuit to ground
Heater Shorted to VCC	Heater short circuit to battery
O2 Sensor Open	Connection to either sensor is open
O2 Sensor Shorted to ground	Short circuit from sensor to ground
O2 Sensor Shorted to VCC	Short circuit from sensor to battery
Lambda Calibration Fault	Lambda reading during calibration is out of range

### **Service**

In case of malfunction, this MSD component will be repaired free of charge according to the terms of the warranty. When returning MSD components for warranty service, **Proof of Purchase** must be supplied for verification. After the warranty period has expired, repair service is based on a minimum and maximum fee.

**All returns must have a Return Material Authorization (RMA) number** issued to them before being returned. To obtain an RMA number please contact MSD Customer Service at 1 (888) MSD-7859 or visit our website at [www.msdpower.com/rma](http://www.msdpower.com/rma) to automatically obtain a number and shipping information.

When returning the unit for repair, leave all wires at the length in which you have them installed. Be sure to include a detailed account of any problems experienced, and what components and accessories are installed on the vehicle. The repaired unit will be returned as soon as possible using Ground shipping methods (ground shipping is covered by warranty). For more information, call MSD at (888) 464-6553. MSD technicians are available from Monday-Friday 7:00 a.m. - 4:00 p.m. and Saturdays from 7:00 a.m.-1 p.m. MST.

### **Limited Warranty**

MSD warrants this product to be free from defects in material and workmanship under its intended normal use\*, when properly installed and purchased from an authorized MSD dealer, for a period of one year from the date of the original purchase. This warranty is void for any products purchased through auction websites. If found to be defective as mentioned above, it will be repaired or replaced at the option of MSD. Any item that is covered under this warranty will be returned free of charge using Ground shipping methods.

This shall constitute the sole remedy of the purchaser and the sole liability of MSD. To the extent permitted by law, the foregoing is exclusive and in lieu of all other warranties or representation whether expressed or implied, including any implied warranty of merchantability or fitness. In no event shall MSD or its suppliers be liable for special or consequential damages.

\*Intended normal use means that this item is being used as was originally intended and for the original application as sold by MSD. Any modifications to this item or if it is used on an application other than what MSD markets the product, the warranty will be void. It is the sole responsibility of the customer to determine that this item will work for the application they are intending. MSD will accept no liability for custom applications.