



15-90 PSI EFI Regulator PN 12-894

WARNING! These instructions must be read and fully understood before beginning the installation. Failure to follow these instructions may result in poor performance, vehicle damage, personal injury, or death. If these instructions are not fully understood, installation should not be attempted.

Parts Included:

- 1 - Adjustable Regulator
- 1 - Regulator Parts Bag includes:
 - 1 - Regulator Mounting Bracket
 - 1 - Brass Hose Barb Fitting
 - 1 - Stainless Steel Pipe Plug
 - 2 - 10-32 x 0.375 Button Head Cap Screws
 - 1 - High Pressure Fuel Hose Clamp

CAPABILITIES

The Holley EFI Regulator is configured for a single -6AN inlet, and dual -6AN outlets (for regulator-to-tank line routing flexibility). The recommended operating range is 15-90 psig (pounds per square inch gauge). The maximum recommended flow rate is 500 liters/hour (2.2 GPM). The vacuum/boost compensation ratio is 1:1.



Figure 1 EFI Regulator

RECOMMENDED PLUMBING SCHEMATICS

When installing the regulator in conjunction with a TBI return system, refer to Figure 2. There are two possible connection points on the throttle body unit, one of which will be the fuel supply in an operational system. DO NOT "tee" into the supply line and leave the -6AN port plug installed on the throttle body. Remove the -6AN port plug from the throttle body and route fuel from that port to the regulator inlet port. The hose length between the throttle body and regulator is not critical, but should be kept to a minimum.

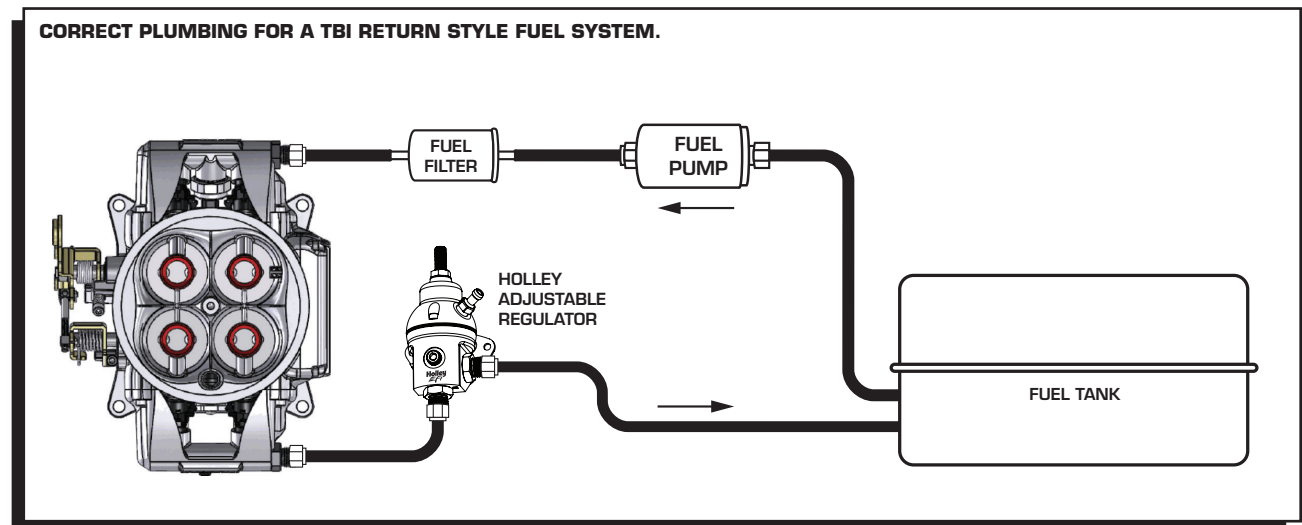

Figure 2 TBI Return Fuel System.

When installing the kit in conjunction with an EFI return system, refer to Figure 3. There are two possible connection points (one at the rear of each fuel rail assembly). One rail will be connected to the fuel supply in an operational system. DO NOT "tee" into the supply line and leave the opposing fuel rail plugged or capped (Figure 5). Fuel from the opposing rail should be routed to the regulator inlet port (using the supplied hose and fittings). The hose length between the rail and regulator is not critical, but should be kept to a minimum.

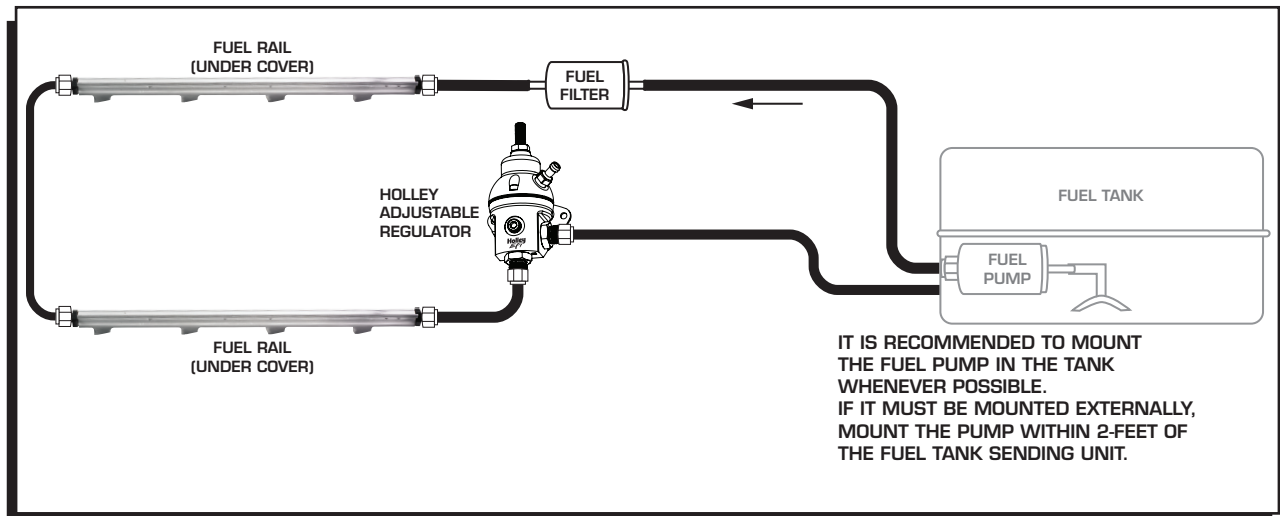

Figure 3 EFI Return Fuel System.

REGULATOR MOUNTING

Using the two (2) supplied 10-32 x 0.375 Button Head Cap Screws and a 1/8-inch hex key (Allen wrench), attach the regulator bracket to the regulator body. The regulator may then be mounted to the firewall, or other convenient surface. Regulator orientation is not critical, but be mindful of adjustment screw access and hose routing. Refer to Figure 4 for a mounting bracket template.

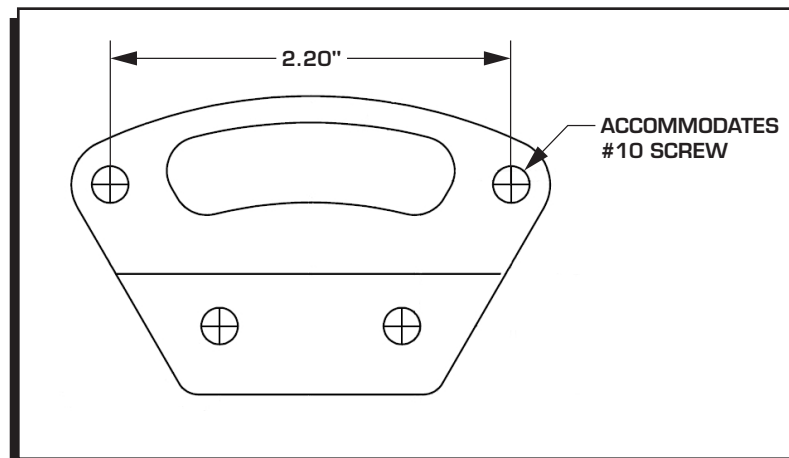

Figure 4 Regulator Mounting Bracket Template

REGULATOR CONNECTIONS AND ADJUSTMENT

The regulator inlet port is located on the bottom surface, and clearly marked with an identifier machined in the housing (see Figure 5). Two (2) outlet ports are available, but typically only one (1) will be used. Install a 6AN port plug in the unused outlet port using a 5/16-inch hex key (Allen wrench). The -6AN straight port fittings should be snugged with an 11/16-inch wrench or deep socket.

Install the supplied 1/8-27 NPT brass hose barb fitting in the upper regulator housing (see Figure 5) using a 7/16-inch wrench or deep socket. Thread sealer is not required on this fitting, but can be used if desired. Connect an intake manifold vacuum / boost source to this fitting, or leave it open to the atmosphere if manifold pressure compensation is not required. DO NOT plug this opening. Ensure that contaminants (such as water and road spray) cannot enter the open fitting. In the event that vacuum / boost reference is

not required, a more cosmetically pleasing option is to install a sintered metal exhaust muffler in this port (such as McMaster-Carr PN 4450K1-Bronze or PN 4402K51-Stainless Steel)

The 1/8-27 NPT port in the lower housing allows the installation of a fuel pressure gauge (direct or remote-reading). If use of this port is not required, install the supplied stainless steel pipe plug using a 3/16-inch hex key (Allen wrench). Use of a fuel compatible paste-type thread sealer is **REQUIRED** on this plug. Thread sealing tape is also an option, but not recommended due to the potential for particulate and debris generation.

Use a 5/32-inch hex key (Allen wrench) to adjust the regulator set point. Clockwise rotation (screw advancing inward) increases the set point, and counter-clockwise rotation (screw advancing outward) decreases the set point. When the desired set point has been reached, snug the jam nut using a 1/2-inch wrench.

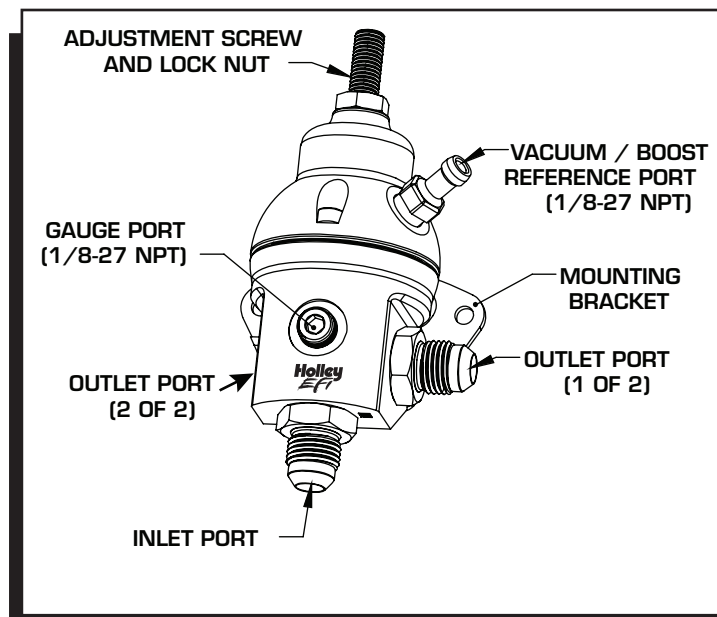

Figure 5 Regulator Feature Identification Guide

STOP HERE

REVIEW YOUR INSTALLATION

Take a few extra minutes to check all aspects of your return fuel system installation at this point. Cycle the key on and off several times to ensure a complete fuel system prime, and verify that all connections and fittings are leak-tight. Don't forget to make the final regulator adjustment with the engine idling.

REGULATOR SERVICE

The regulator diaphragm assembly is available as a service kit and considered a user-serviceable item. Detailed instructions are available in the service kit, but for completeness, the following guidelines must be observed if it is necessary to separate the regulator housings.

- Use a 9/64-inch hex key (Allen wrench) to remove the three (3) 8-32 x 0.375 Socket Head Cap Screws
- Use care not to lose any internal parts (particularly the ¼-inch ball beneath the adjustment screw)
- Upon re-assembly, ensure that no debris or particulates are trapped between the housing mating surfaces (these may cut or damage the diaphragm)
- Align the diaphragm slots with the three (3) screw holes and stack the spring assembly prior to installing the upper housing
- Install the three (3) 8-32 x 0.375 SHCS to a staged final torque of 25-28* in-lb.
 - o Stage 1 Torque: 10 in-lb
 - o Stage 2 Torque: 20 in-lb
 - o Stage 3 (final) Torque: 25-28* in-lb.

* Verify the Stage 3 torque after at least one hour has elapsed (to allow for diaphragm compression set)

Use compressed air (or equivalent) to ensure that all complete hose/fitting assemblies are clean prior to final installation.

Technical Service: 1-866-464-6553
www.holley.com

© 2021 Holley Performance Products, Inc. All rights reserved. Tous Droits Réservés.

FRM36127

Date: 02/24
