

Fuel System #3

Vent

- #6 minimum
- do not use gas cap as vent

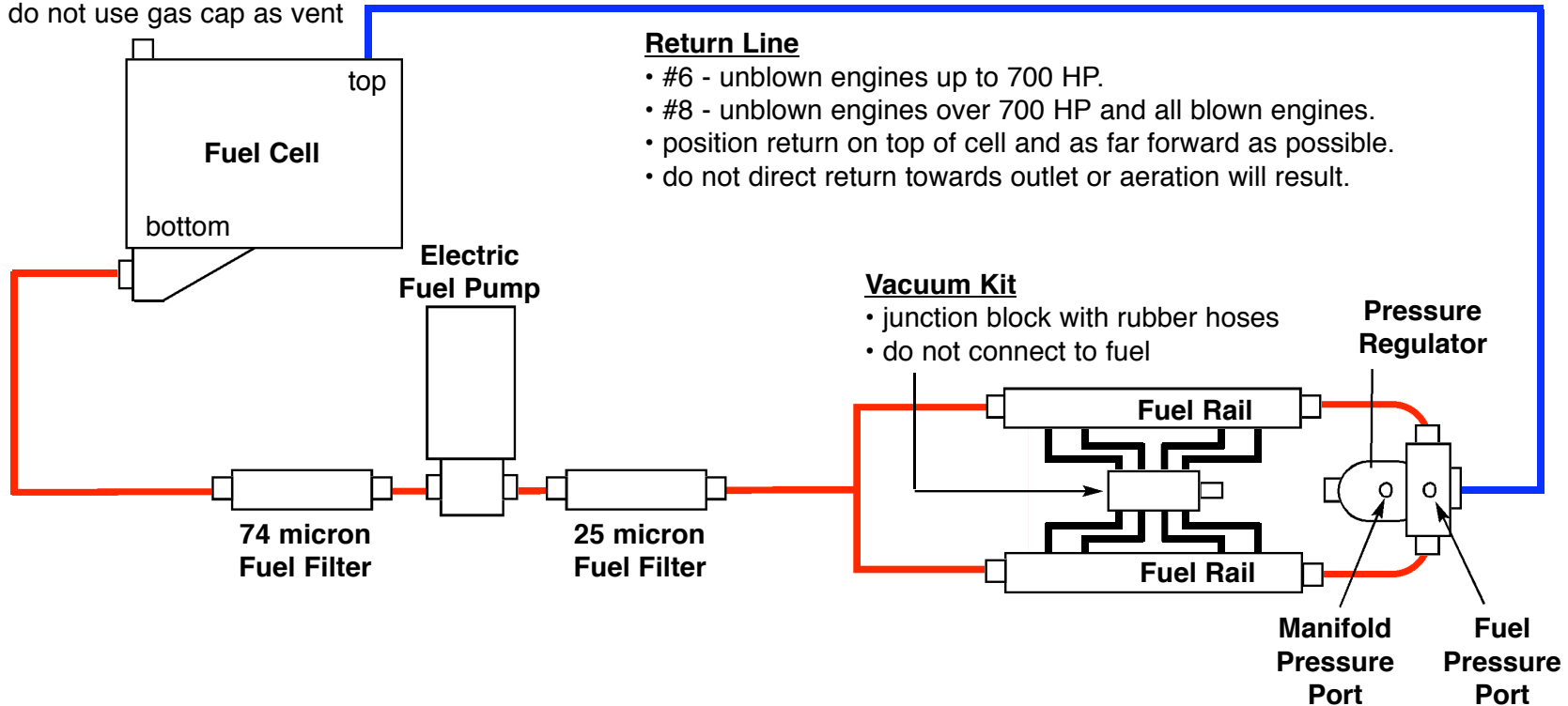

Return Line

- #6 - unblown engines up to 700 HP.
- #8 - unblown engines over 700 HP and all blown engines.
- position return on top of cell and as far forward as possible.
- do not direct return towards outlet or aeration will result.

Vacuum Kit

- junction block with rubber hoses
- do not connect to fuel

Pressure Regulator

Manifold Pressure Port
Fuel Pressure Port

Fuel Cell or Tank

- for optimum installation position outlet as low on cell and as far rearward as possible.
- avoid sharp bends and machined fittings.
- use only full flow hose ends.
- do not use an intank filter.
- clean and flush tank before installation.
- inspect and clean filters frequently if tank is dirty.

Pressure Regulator

- mount within 3 feet of fuel rail or junction block of fuel supply.
- side fittings are pressure - in or out.
- bottom fitting is return to tank.
- do not boost - reference regulator.
- vacuum to regulator can be used to reduce fuel pressure at idle.

Fuel Lines

- consult factory for specific fuel line size.
- thoroughly flush all fuel lines before use.