

# JAMMER

CAI

## INSTALL GUIDE

2012-2017  
Jeep Wrangler JK  
3.6L V6

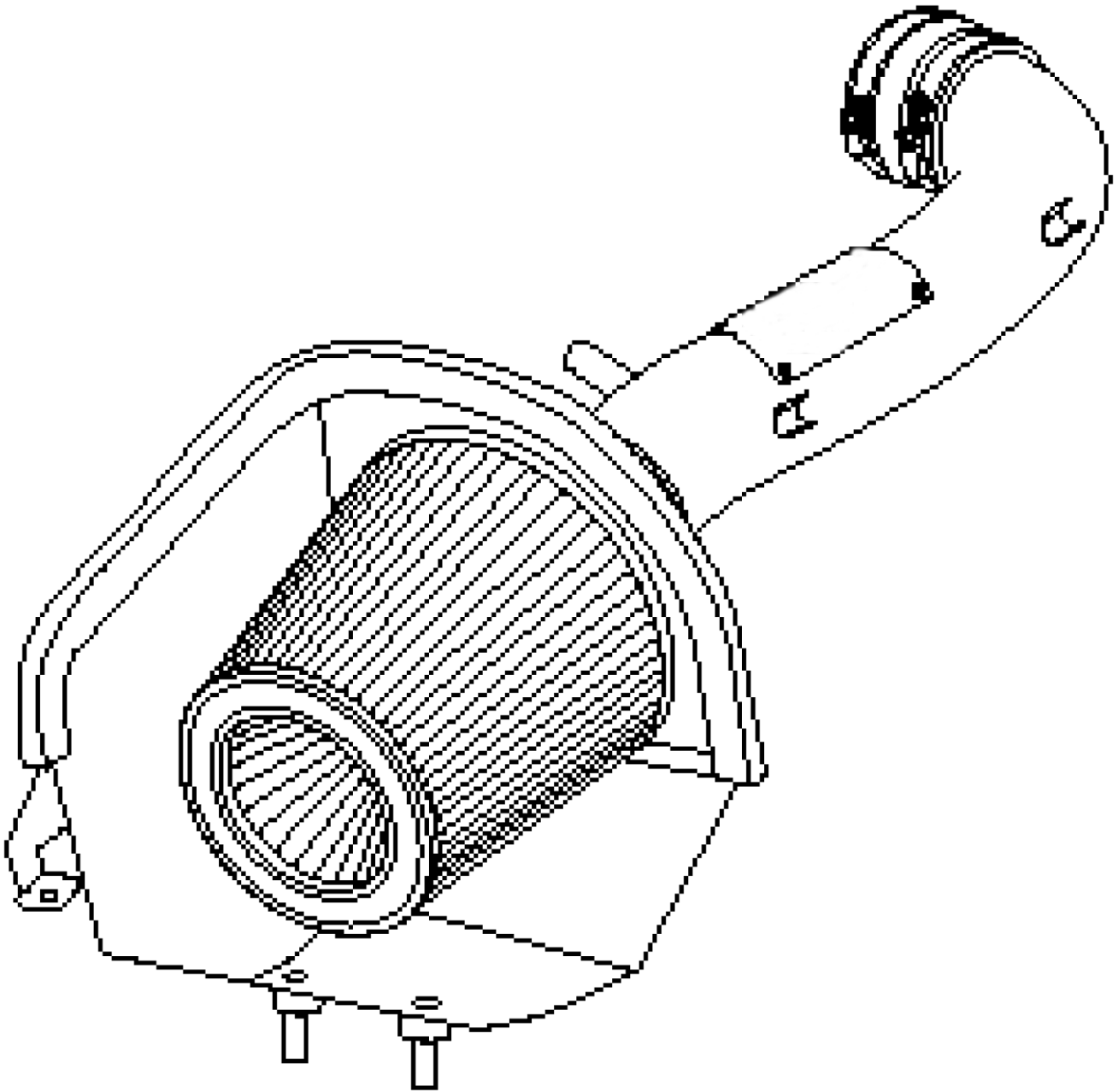

# TABLE OF CONTENTS

---

---

<b>3</b>	<b>GETTING STARTED</b>
3	PARTS LIST
<b>4</b>	<b>INSTALLATION INSTRUCTIONS</b>
4	REMOVING THE STOCK INTAKE ASSEMBLY
6	INSTALLING THE HOUSING
7	INSTALLING THE INTAKE TUBE
8	INSTALLING THE AIR FILTER
<b>10</b>	<b>WARRANTY</b>

# GETTING STARTED

## PARTS LIST

Item	Description	Qty
1	Air Filter.....	1
2	Housing.....	1
3	Intake Tube.....	1
4	Coupling, Hump.....	1
5	Coupling, Straight.....	1
6	Clamp, #072.....	2
7	Clamp, #052.....	2
8	9" Hose.....	1
9	Grommet .....	1
10	Button Head Screw.....	5
11	Washer, Wavy.....	5
12	Adapter.....	2
13	Urethane Spacer.....	1
14	Seal Trim(24.5Inches).....	1



# INSTALLATION INSTRUCTIONS

## REMOVING THE STOCK INTAKE ASSEMBLY

*CAUTION: Disconnect the ground cable from the battery before installation.*

**STEP 1** - Remove the top engine cover.



**STEP 2** - Remove the two 10mm bolts from the intake tube.

**STEP 3** - Disconnect the temp sensor wire harness.

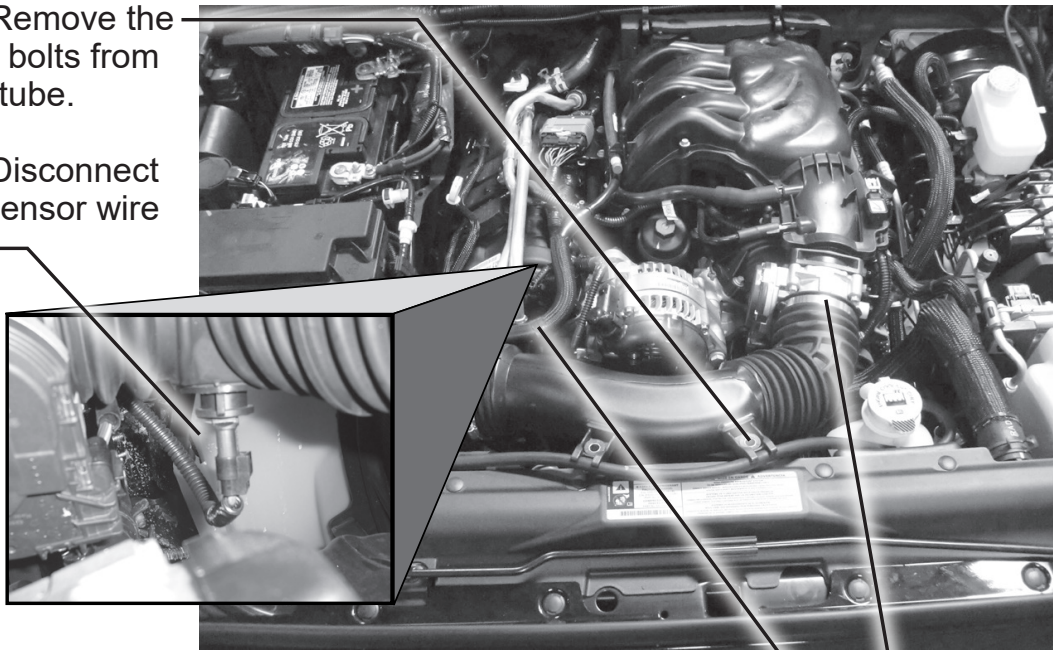

**STEP 4** - Completely remove the small section of crankcase vent (CCV) hose. It should be pulled off of the air filter housing and the tube to the engine.

**STEP 5** - Loosen the hose clamp at the throttle body.

**STEP 6** - Remove the stock intake tube, and air filter housing by pulling straight up and out of the vehicle.

---

**STEP 7** - Twist the temp sensor about 45 degrees counter-clock-wise and pull it straight up to remove from stock tube.

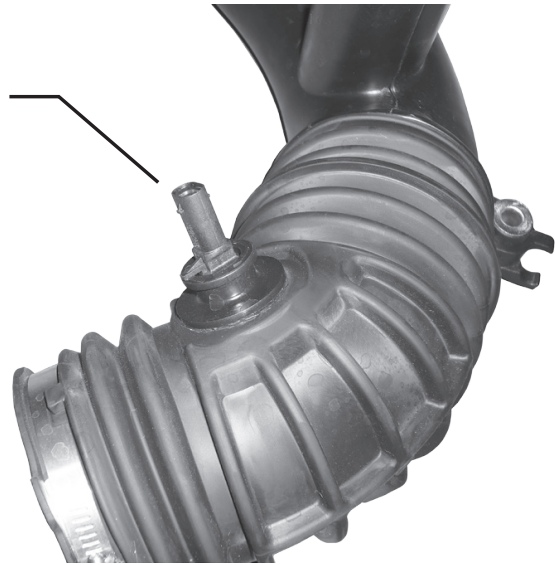

**STEP 8** - Remove the 10mm bolt that secures the plastic tray onto the inner fender, but do not remove the plastic tray.

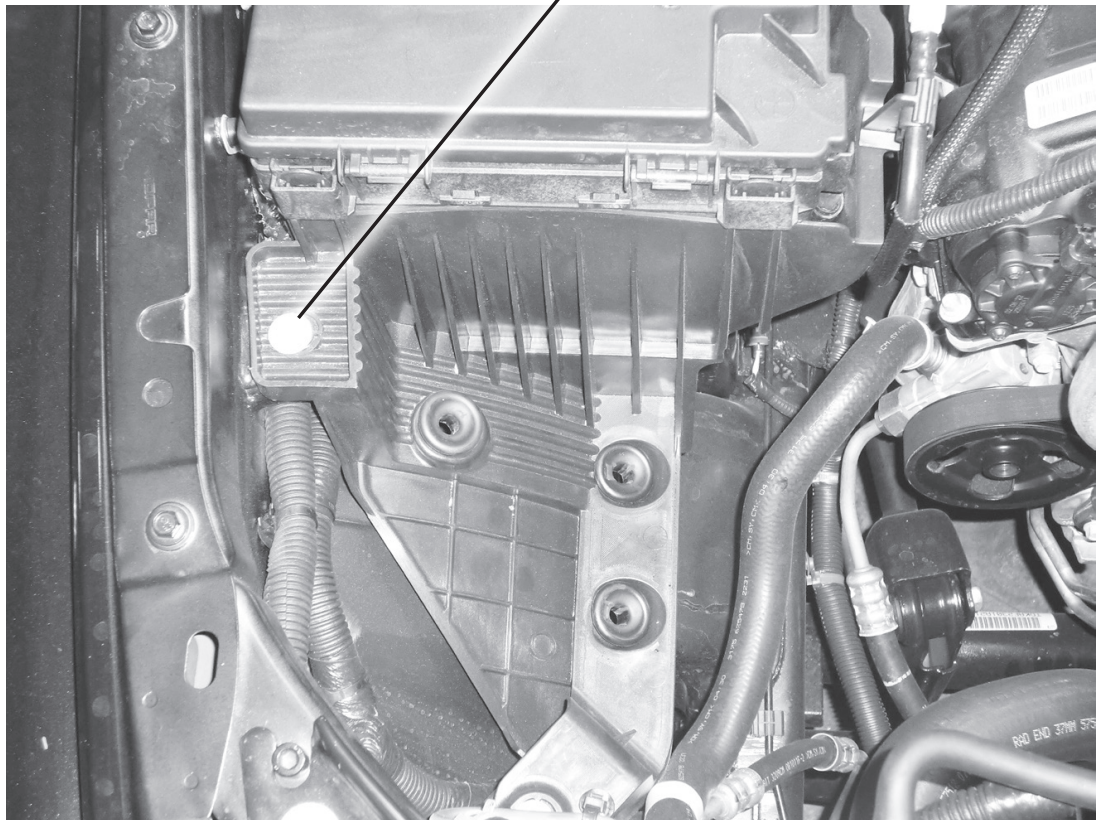

---

## INSTALLING THE HOUSING

---

**STEP 9** - Install the air filter adaptor in the housing and secure using the 5 washers and screws provided.

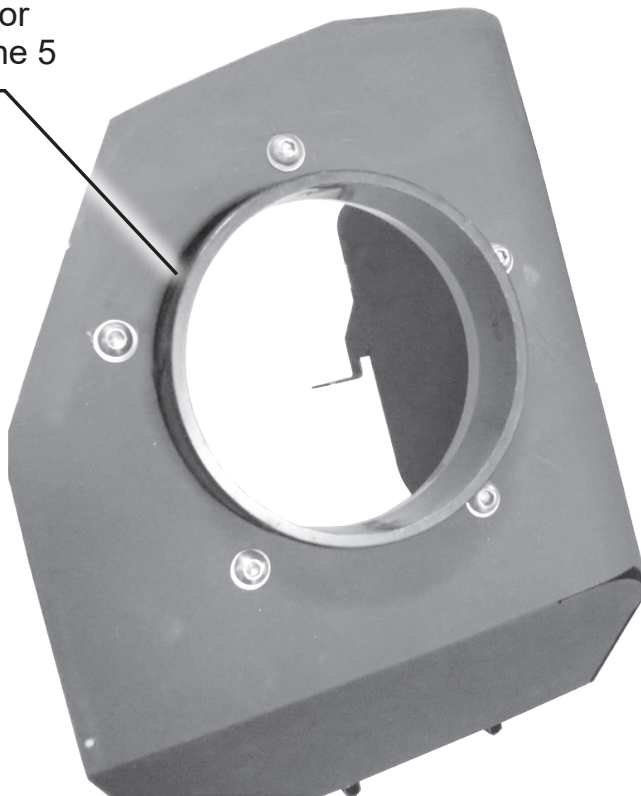

**STEP 10** - Install the trim seal on the housing.

**STEP 11** - Install the spacers on the pegs located on the bottom of the housing.

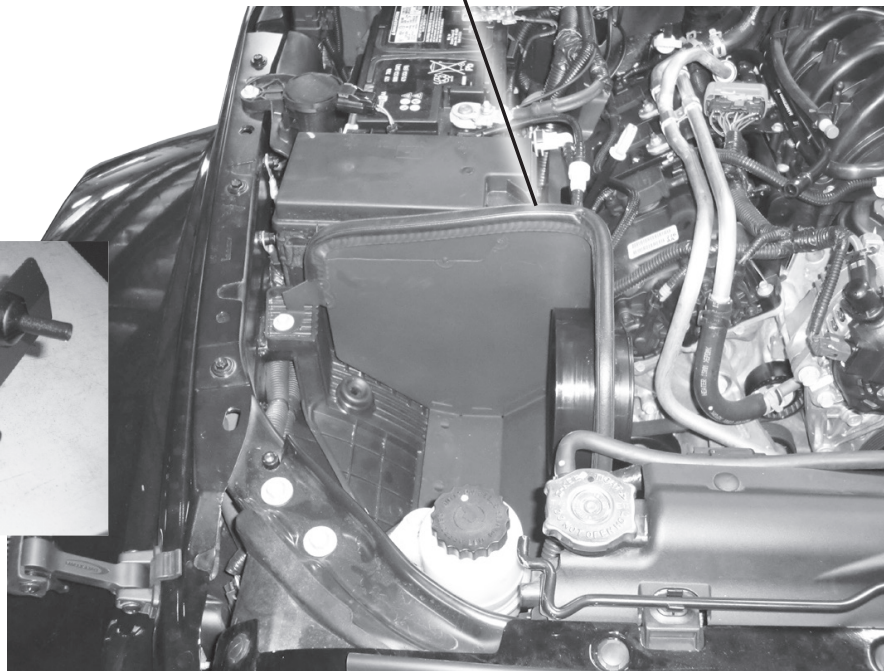
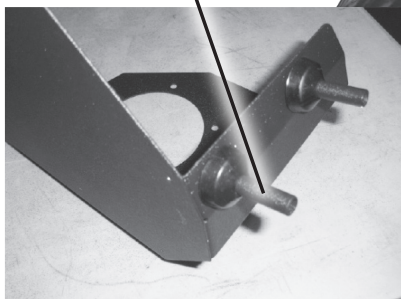

**STEP 12** - Install the assembled housing into the vehicle as shown. Secure the housing using the OE bolt removed from Step 8.

---

## INSTALLING THE INTAKE TUBE

---

**STEP 13** - Insert the provided grommet into the new AFE intake tube.

**STEP 14** - Insert the OE temp sensor into the grommet.



**STEP 15** - Install the provided couplings and clamps onto the vehicle:  
The straight coupling goes on the throttle body.  
The hump coupling goes on the air filter adapter.

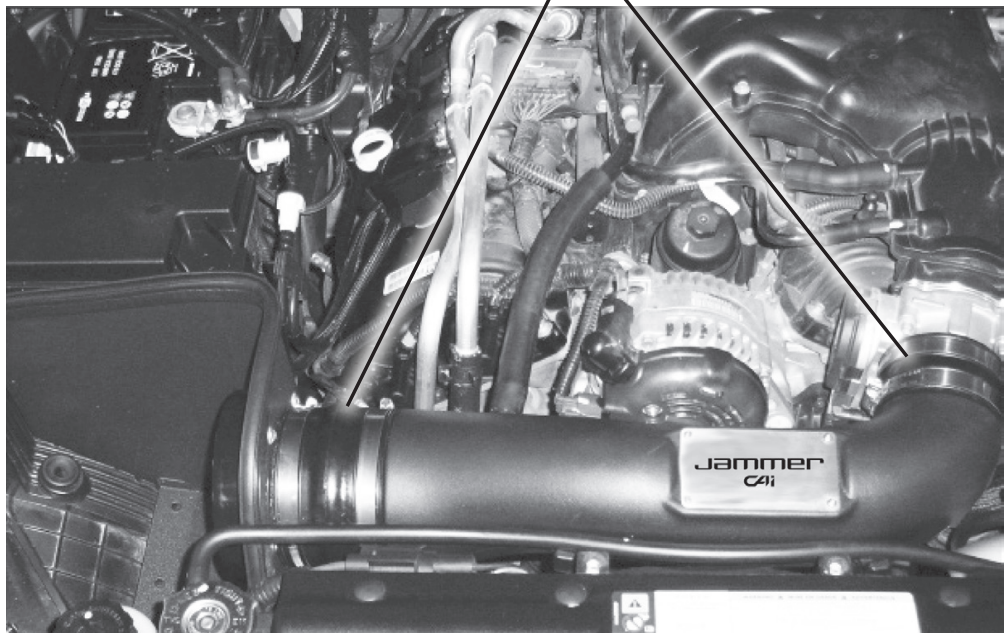

**STEP 16** - Install the intake tube as shown. Align the tube so that the coolant return line runs above the fan shroud.

**STEP 17** - Plug in the temp sensor harness.

**STEP 18** - Install the new CCV hose. (Note: use lubricant on the outside of the OE tube)

**STEP 19** - Snap the coolant line into the clips on the front of the intake tube.

---

## INSTALLING THE FILTER

---

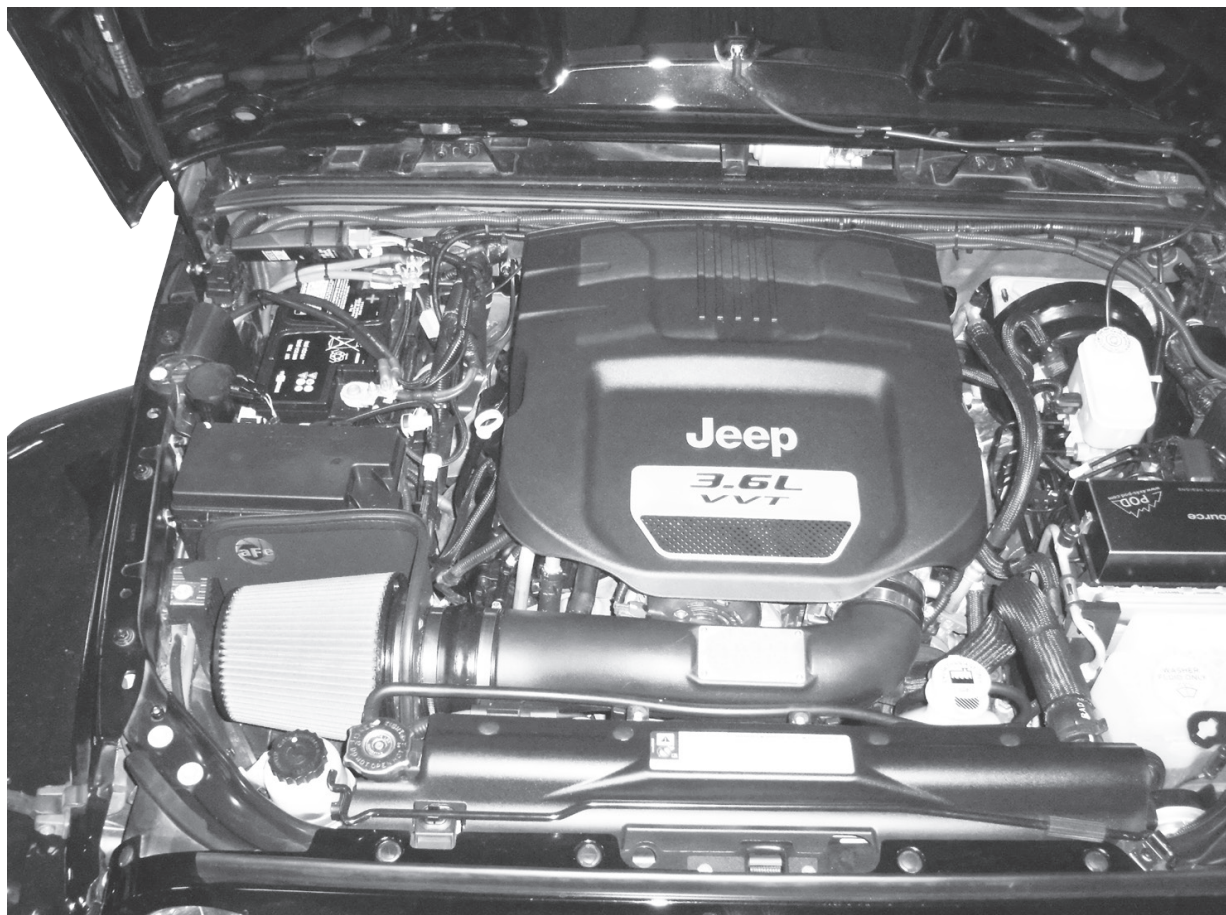

**STEP 20** - Install the air filter.

**STEP 21** - Tighten all clamps.

**STEP 22** - Reinstall the engine cover. Your installation is now complete.

**NOTE:** Retighten all connections after approximately 100-200 miles.



---

---

Intentionally left blank

# WARRANTY

---

Powerteq, LLC, (hereafter “SELLER”), subject to the conditions and limitations set forth herein, warrants to the original consumer purchaser only that each Jammer product sold by SELLER (the “Product”) through an authorized dealer will be free from defects in material and workmanship under normal operating conditions for one (1) year after the date of purchase. SELLER will repair or replace, at SELLER’s option, any Product that is found to be defective in material or workmanship under normal operating conditions during the one-year period after the date of purchase by the original consumer purchaser.

## **What Is Not Covered by This Warranty?**

This warranty does not apply to any of the following:

1. Loss, damage, repairs, or maintenance required as a result of accident, abuse, negligence, or misuse.
2. Loss, damage, repairs, or maintenance required as a result of any third-party tuning software.
3. Loss, damage, repairs, or maintenance required as a result of fire, water, hail, theft, earthquake, wind, ice, lightening, acts of god, accident, animals, corrosive atmosphere, or other external causes beyond the control of SELLER.
4. Any special, indirect, incidental, consequential, or punitive damages, including property damage, arising out of or related to the use or loss of use of the Product under this Limited Warranty.
5. Any Products purchased through auction websites.

## **Limitation of Liability**

The terms of this Limited Warranty constitute the entire agreement between the parties with respect to the Product. The original consumer purchaser’s exclusive remedy shall be limited to the repair or replacement of the defective product. EXCLUDING THE LIMITED WARRANTY PROVIDED ABOVE, SELLER, TO THE MAXIMUM EXTENT PERMITTED BY LAW, MAKES NO WARRANTIES, EXPRESSED OR IMPLIED, AND DISCLAIMS ALL WARRANTIES, DUEITES AND CONDITIONS, WHETHER EXPRESS, IMPLIED, OR STATUTORY, WITH RESPECT TO THE WORK, INCLUDING WITHOUT LIMITATION ANY IMPLIED WARRANTIES OF MERCHANTABILITY OR FITNESS FOR A PARTICULAR PURPOSE. ANY REMEDY IS LIMITED TO THE PURCHASE PRICE OF THE PRODUCT.

---

### **How to Make a Warranty Claim**

Contact Powerteq Customer Service. BUYER will be required to submit proof of purchase from an authorized dealer within 5 days of the warranty claim.

THE INSTALLATION OF THIS PRODUCT INDICATES THAT THE BUYER HAS READ AND UNDERSTANDS THIS AGREEMENT AND ACCEPTS ITS TERMS AND CONDITIONS. IN THE EVENT THAT THE BUYER DOES NOT AGREE WITH THIS AGREEMENT, THE BUYER MAY PROMPTLY RETURN THIS PRODUCT, IN A NEW AND UNUSED CONDITION, WITH A DATED PROOF OF PURCHASE, TO THE PLACE OF PURCHASE WITHIN THIRTY (30) DAYS FROM DATE OF PURCHASE FOR A FULL REFUND.

**COPYRIGHT© 2017 REV 00**

*For additional questions not found in the user guide call:*

**Powerteq Technical Support: (855) 292-2121 6:00 am - 5:00 pm MST**

**To expedite your support call, please have your Vehicle Information,  
Part Number, and Serial Number ready prior to calling Technical Support.**